

Porcellana

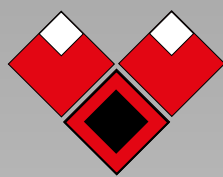

VEZZANI



VEZZANI®

ACCIAIO INOX • FONDERIE D'ARTE • PORCELLANE

Catalogo Luglio 2017



Porcellana



Serie Complete
da pag. 412

*Complete Series
from pag. 412*



Targhe
da pag. 534

*Plates
from pag. 534*



Marmo
da pag. 591

*Marble
from pag. 951*



Acciaio Inox
da pag. 637

*Stainless steel
from pag. 637*



Ossari e cinerari
da pag. 520

*Charnel Houses
from pag. 520*



Statue
da pag. 552

*Statues
from pag. 552*



Stonat
da pag. 611

*stonat
from pag. 611*



Urne
da pag. 689

*Urns
from pag. 689*



Cornici, Croci e
Portaritratti
da pag. 527

*Frames, Crosses,
Photograph-frames
from pag. 527*



Caratteri
da pag. 560



*Fonts
from pag. 560*



Cristalli e
Fiamme
da pag. 632

*Crystals and
Flames
from pag. 632*



Lumini Votivi
da pag. 706

*Small votive
lamps from
pag. 706*



Lampade
da appendere
Borchie
da pag. 530

*Hanging lamps
Studs
from pag. 530*



Pergamene,
Libri
e Monosystem
da pag. 572

*Parchments
Books
and Monosystem
from pag. 572*



Fioriere ed
incassi
da pag. 532

*Flower-Box and
Cavities
from pag. 532*



Composizioni
floreali
da pag. 581

*Floreal
composition
from pag. 581*



Scarica il PDF del
catalogo completo
*Download complete
PDF catalogue*

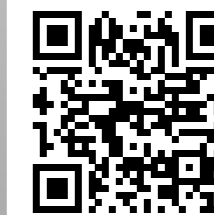

Guarda le News
Vezzani
*Refer to
Vezzani News*

LEGENDA DELLE ABBREVIAZIONI



P	= Parete
T	= Terreno
Pr. lega Bronzo	= Primaria lega pat. Bronzo
Inox	= Acciaio inox
P	= Interno in plastica
R	= Interno in rame
R/C	= Interno in rame cromato
I	= Interno in acciaio inox
∅	= Fiamma
↓	= Altezza
↔	= Larghezza
↙	= Profondità

KEY TO ABBREVIATIONS



P	= Wall
T	= Ground
Pr. lega Bronzo	= Bronze coated primary alloy
Inox	= Stainless steel
P	= Plastic interior
R	= Copper interior
R/C	= Chrome plated copper interior
I	= Stainless steel interior
∅	= Flame
↓	= Height
↔	= Width
↙	= Depth

LEGENDE DES ABBREVIATIONS



P	= Mur
T	= Sol
Pr. lega Bronzo	= Alliage primaire couché bronze
Inox	= Acier inoxydable
P	= Intérieur en plastique
R	= Intérieur en cuivre
R/C	= Intérieur en cuivre chromé
I	= Intérieur en acier inox
∅	= Flamme
↓	= Hauteur
↔	= Largeur
↙	= Profondeur

LEGENDE DER ABKÜRZUNGEN



P	= Wand
T	= Boden
Pr. lega Bronzo	= Primäre bronzebeschichtete Legierung
Inox	= Edelstahl
P	= Innen aus Plastik
R	= Innen aus Kupfer
R/C	= Innen aus verchromtem Kupfer
I	= Innen aus rostfreier Stahl
∅	= Flamme
↓	= Höhe
↔	= Breite
↙	= Tiefe

LISTA DE ABBREVIATURAS



P	= Pared
T	= Terreno
Pr. lega Bronzo	= Primaria aleación patinada de bronce
Inox	= Acero inoxidable
P	= Interior de plástico
R	= Interior de cobre
R/C	= Interior de cobre cromado
I	= Interior de acero inox
∅	= Llama
↓	= Altura
↔	= Anchura
↙	= Profundidad

LEGENDA DAS ABBREVIATURAS



P	= Parede
T	= Terreno
Pr. lega Bronzo	= Liga patinada de bronze de primeira qualidade
Inox	= Aço inox
P	= Interior em plástico
R	= Interior em cobre
R/C	= Interior em cobre cromado
I	= Interior em aço inox
∅	= Chama
↓	= Altura
↔	= Largura
↙	= Profundidade

ΕΠΕΞΗΓΗΣΗ ΣΥΝΤΜΗΣΕΩΝ



P	= Τοίχος
T	= Έδαφος
Pr. lega Bronzo	= Πρωτογενές κράμα οξειδ. ορειχάλκου
Inox	= Ανοξειδωτός χάλυβας
P	= Εσωτερικό από πλαστικό
R	= Εσωτερικό από χαλκό
R/C	= Εσωτερικό από επιχρωμιωμένο χαλκό
I	= Εσωτερικό από ανοξειδωτο χάλυβα
∅	= Εμβλημα
↓	= Ύψος
↔	= Πλάτος
↙	= Βάθος

LEGENDA DELLE ABBREVIAZIONI E TERMINOLOGIE



BRONZO: Il termine bronzo, riportato all'interno del presente catalogo, può essere utilizzato per:

- individuare il solo aspetto superficiale di un prodotto
- indicare una lega di rame-stagno con una percentuale di rame non inferiore dell'85% e aggiunta di altri elementi (per i prodotti eseguiti con la fusione a cera persa).
- indicare una lega di rame-zinco con una percentuale di rame non inferiore al 65% e aggiunta di altri elementi (per i prodotti eseguiti con la fusione in terra e Pressofusione), con aspetto superficiale tipo bronzo.

Tutti i prodotti illustrati, dotati di fiamma caratteristica di vetro, che sono predisposti per contenere lampadine per l'illuminazione e che saranno collegati ad un impianto elettrico, possono essere destinati all'uso, solo se verranno applicate tensioni nominali inferiori ai 50 Volt in corrente alternata e ai 75 Volt in corrente continua. Restano comunque a carico dell'installatore tutti gli obblighi dettati dalla Legislazione vigente nel momento in cui tali prodotti verranno inseriti in un impianto elettrico. È fatto divieto di impiegare i prodotti del presente catalogo in ambiente con pericolo/rischio di esplosione.

In tutti i portalampe è vietato introdurre il cero. Il cero è applicabile solo sui modelli prestabiliti; in talune condizioni/modelli, il cero potrebbe surriscaldare la superficie esterna della "lampada cero".

KEY TO ABBREVIATIONS AND TERMINOLOGIES



BRONZE: The word bronze, that is written inside this catalogue, can be used:

- to indicate the surface of a product
- to indicate an alloy of copper-tin with a percentage of copper not lower than 85% and the adding of other elements (for products made with lost-wax casting)
- to indicate an alloy of copper-zinc with a percentage of copper not lower than 65% and the adding of other elements (for products made with the ground casting and Die-casting) with a bronze type surface.

All the illustrated products, equipped with characteristic glass flame, that are arranged to contain lamps and to be connected to an electric plant, can be used like this, only when voltages lower than 50 Volt in alternate current and than 75 Volt in direct current are applied. The installer has the responsibility to meet all the law requirements in force at the moment in which these products are inserted in an electric plant. Using the products of this catalogue in a place with danger of explosion is not allowed.

No put the large candle inside any lamp holder. The large candle can only be put in the established models; in some conditions/models, the large candle could heat the external surface of the "large candle lamp".

LEGENDE DER ABKÜRZUNGEN UND TERMINOLOGIEN



BRONZE: Das Wort Bronze, das in diesem Katalog anwesend ist, wird benutzt um:

- nur die Fläche eines Produktes zu bestimmen;
- eine Legierung von Kupfer-Zinn mit einem Prozent von Kupfer nicht niedriger als 85% und den Zusatz von anderen Elementen zu zeigen (für Produkte aus Wachsaußschmelzverfahren)
- eine Legierung von Kupfer-Zinn mit einem Prozent von Kupfer nicht niedriger als 65% und den Zusatz von anderen Elementen (für Produkte aus Grundschmelzung und Druckguss) mit einer Fläche Bronzetypp zu zeigen.

Alle die gezeigte Produkte, ausgestattet mit einer Glasflamme, die zur Enthaltung einer Lampe vorbereitet sind und die zu einer elektrischen Anlage verbunden werden, können mit diesem Ziel benutzt werden nur mit Nennspannungen niedriger als 50 Volt in Wechselstrom und niedriger als 75 Volt in Gleichstrom. Der Installateur ist für alle die Pflichte des gültigen Gesetzes verantwortlich, wenn diese Produkte in einer elektrischen Anlage eingesteckt werden. Es ist verboten diese Produkte in Räume, wo es Explosionsgefahr gibt, zu benutzen.

Es ist verboten die Kerze in aller Lampenfassungen einzustellen. Die Kerze wird nur auf die festgelegte Modellen gestellt; in einigen Bedienungen/Modellen, könnte die Kerze die Außenfläche der "Kerzelampe" überheizen.

LEGENDA DAS ABBREVIACÕES E TERMINOLOGIAS



BRONZE: O termo bronze, mencionado neste catálogo, pode ser utilizado para:

- identificar apenas o aspecto superficial de um produto;
- indicar uma liga de cobre-estanho com um percentual de cobre não inferior a 85% e com outros elementos (para os produtos realizados com fundição por cera perdida);
- indicar uma liga de cobre-zinco com um percentual de cobre não inferior a 65% e com outros elementos (para os produtos realizados com a fundição na terra e Vaciado a presion), com aspecto superficial tipo bronze.

Todos os produtos ilustrados, dotados de chama característica de vidro, que são predispostos para conter pequenas lâmpadas para a iluminação e que serão ligados à instalação eléctrica, podem ser destinados ao uso, somente se forem aplicadas tensões nominais inferiores a 50 Volts em corrente alternada e a 75 Volts em corrente contínua. Ficam, portanto, a cargo do instalador todas as obrigações previstas pela Legislação vigente no momento em que esses produtos forem inseridos numa instalação eléctrica. É absolutamente proibido utilizar os produtos deste catálogo em ambiente com perigo ou risco de explosão.

Em todos os porta-lâmpadas é proibido colocar velas. A vela é aplicável somente nos modelos pré-estabelecidos; em certas condições ou em certos modelos, a vela pode aquecer a superfície externa da "lâmpada tipo vela".

LEYENDA DE ABBREVIATURAS Y TERMINOLOGÍA



BRONZE: El término bronce utilizado en el presente catálogo puede ser utilizado para:

- Individuar el aspecto superficial de un producto.
- Indicar una aleación de cobre-estaño con un porcentaje de cobre no inferior al 85% y adición de otros elementos (para los productos realizados con la fusión en cera perdida).
- Indicar una aleación de cobre-zinc con un porcentaje de cobre no inferior al 65% y adición de otros elementos (para los productos realizados con la fusión en tierra e Vaciado a presión), con aspecto superficial tipo bronce.

Todos los productos mostrados en el catálogo provistos de la característica llama de cristal, predispostos para contener bombillas para la iluminación y que deben conectarse a una instalación eléctrica, pueden ser destinados a tal fin sólo si se aplican tensiones nominales inferiores a 50 Voltios en corriente alterna e inferiores a 75 Voltios en corriente continua. Quedan a cargo del instalador todas las obligaciones dictadas por la legislación vigente cuando dichos productos se conecten a una instalación eléctrica. Queda prohibido utilizar los productos del presente catálogo en ambientes con peligro o riesgo de explosión.

Está prohibido introducir velas en todos los modelos de portalamparas. La vela sólo puede aplicarse en los modelos preestablecidos; en determinadas condiciones o modelos, la vela podría sobrecalentar la superficie externa de la "lámpara vela".

EXPLICATION DES ABBREVIATIONS ET TERMINOLOGIE



BRONZE: Dans le présent catalogue, le terme bronze peut être utilisé pour:

- indiquer le seul aspect superficiel d'un produit;
- désigner un alliage de cuivre et étain contenant un pourcentage de cuivre non inférieur à 85% et autres éléments (pour les produits réalisés par fusion à cire perdue);
- désigner un alliage de cuivre et zinc contenant un pourcentage de cuivre non inférieur à 65% et autres éléments (pour les produits réalisés par fusion en terre et Moulage sous pression), d'aspect superficiel s'apparentant au bronze.

Tous les articles représentés, dotés d'une flamme caractéristique en verre, prévus pour contenir des ampoules d'éclairage et devant à cet effet être branchés à un circuit d'alimentation électrique, peuvent être utilisés comme tels à condition d'être alimentés à une tension nominale inférieure à 50V en courant alternatif ou 75V en courant continu. Toutes les obligations imposées par les dispositions légales en vigueur au moment où les produits sont installés sur les circuits électriques incombent à l'installateur. Il est interdit d'utiliser les articles du présent catalogue dans un environnement exposés à des dangers/risques d'explosion.

Il est interdit de placer des cierges dans les douilles pour ampoules. Le cierge peut être utilisé uniquement sur les modèles prévus à cet effet. Dans certaines conditions et/ou sur certains modèles, le cierge pourrait surchauffer la surface externe de la "lampe cierge".

ΥΠΟΜΝΗΜΑ ΤΩΝ ΣΥΝΤΟΜΕΥΣΕΩΝ ΚΑΙ ΤΩΝ ΟΡΩΝ



ΜΠΡΟΥΝΤΖΟΣ: Ο όρος μπρούντζος, που αναφέρεται στο εσωτερικό του παρόντος καταλόγου, μπορεί να χρησιμοποιείται για:

- να προσδιορίζει μόνο την επιφανειακή όψη ενός προϊόντος
- να υποδεικνύει ένα κράμα χαλκού-κασσιτέρου με ποσοστό χαλκού όχι μικρότερο του 85% και προσθήκη άλλων στοιχείων (για τα προϊόντα που παράγονται με χύτευση σε κερί)
- να υποδεικνύει ένα κράμα χαλκού-μειδαργύρου με ποσοστό χαλκού όχι μικρότερο του 65% και προσθήκη άλλων στοιχείων (για τα προϊόντα που παράγονται με χύτευση σε άμμο- κύβος), με επιφανειακή όψη όπως του μπρούντζου.

Όλα τα απεικονιζόμενα προϊόντα, που διαθέτουν χαρακτηριστική υαλώδη λάμψη, που προορίζονται για να δεχτούν λυχνίες για το φωτισμό και που θα συνδεθούν σε μια ηλεκτρική εγκατάσταση, μπορεί να προορίζονται για χρήση, μόνο αν εφαρμοστούν ονομαστικές τάσεις μικρότερες των 50 Volt εναλλασσόμενου ρεύματος και 75 Volt συνεχούς ρεύματος. Ωστόσο αποτελεί υποχρέωση του τεχνικού εγκατάστασης όλα όσα ορίζονται από την ισχύουσα Νομοθεσία κατά τη στιγμή που τα προϊόντα αυτά θα εισαχθούν σε μια ηλεκτρική εγκατάσταση. Απαγορεύεται η χρήση προϊόντων του παρόντος καταλόγου σε χώρο επικινδύνου με πιθανότητα έκρηξης.

Σε όλα τα ντουί απαγορεύεται η εισαγωγή λαμπάδας. Η λαμπάδα εφαρμόζεται μόνο στα προκαθορισμένα μοντέλα. Σε ορισμένες περιπτώσεις/μοντέλα, η λαμπάδα μπορεί να υπερθερμάνει την εξωτερική επιφάνεια της «λυχνίας τύπου λαμπάδας».

PORCELLANA, IL PRESTIGIO DI UNO STILE INCONFONDIBILE

É nella porcellana che la Vezzani raggiunge l'eccellenza, realizzando quella sintesi di tradizione ed innovazione che caratterizza lo stile inimitabile dei suoi prodotti. Il segreto della porcellana è nella sua forza eterea, così delicata da sembrare misteriosa, eppure destinata a testimoniare nei secoli la serietà di un'azienda, la professionalità e l'impegno degli uomini che l'hanno resa famosa nel mondo.

PORCELAIN, THE PRESTIGE OF UNMISTAKABLE ELEGANCE

Vezzani have achieved levels of excellence with porcelain, producing a synthesis of tradition and innovation that characterizes the inimitable style of its products.

Porcelain's secret is in its ethereal power, so delicate as to appear mysterious, but destined throughout the centuries to prove the sincerity of a company, the professional know-how and commitment of the personnel that have made it famous worldwide.



Colaggio
porcellana
liquida



La Vezzani S.p.A. è la prima e la più importante azienda del settore che può vantare il primato del rilancio della tradizione millenaria della porcellana sul mercato funerario internazionale, in sintonia con le esigenze moderne grazie ai più avanzati ritrovati dell'arte e della tecnica. La Vezzani s.p.a. è in condizione di comunicare alla propria clientela che all'altissima qualità della propria linea di prodotti di porcellana consegue la sua sostanziale inalterabilità nel tempo, e in particolare, la sua resistenza al sole, al gelo, alla salsedine, alle piogge acide e a tutte le forme di inquinamento. Una qualità che l'operatore del settore potrà a propria volta rendere nota al suo cliente, qualificando così il proprio lavoro con un prodotto che non porrà problemi perché praticamente eterno, salvo invecchiamento naturale dei particolari metallici e degli eventuali decori.

La Vezzani s.p.a. di buon grado rilascia per iscritto tale attestazione alla propria clientela, che le ha permesso, concedendole la sua fiducia, di diventare l'azienda leader nel mondo in tale settore.

Con gratitudine.

GB

Vezzani s.p.a. is the sector's most important company and the first able to boast leadership on the international funerary market with the revival of the age-old tradition of porcelain, in step with modern demands thanks to the most advanced discoveries in art and technology.

Vezzani s.p.a. is able to inform its customers that its line of porcelain products is of the highest quality making it essentially unalterable over time and, in particular, resistant to the sun, frost, salt, acid rain, and all form of pollution. A quality that sector operators may in turn make known to their customers, characterizing their work with a product that will not create problems because, except for the natural ageing of the metal parts and any decorations, its practically eternal.

Vezzani s.p.a. takes pleasure in providing this written statement to its customers, whose trust has allowed it to become this sector's world leader.

Many thanks.

E

Vezzani s.p.a. es la primera y la más importante empresa del sector que puede jactarse de haber sido la primera en relanzar la tradición milenaria de la porcelana en el mercado funerario internacional, en sintonia con las exigencias modernas gracias a los descubrimientos más avanzados del arte y de la técnica. La empresa Vezzani s.p.a. está en condiciones de comunicar a la propia clientela que a la elevadísima calidad de su línea de productos de porcelana sigue, como consecuencia, su substancial inalterabilidad en el tiempo y, de particular modo, su resistencia al sol, al hielo, a la sal, a las lluvias ácidas y a todas las formas de contaminación. Una calidad que el operador del sector podrá a su vez hacerla conocer a sus clientes, cualificando de esta manera el propio trabajo con un producto que no causará problemas pues es prácticamente eterno, excepto el envejecimiento natural de los eventuales decoraciones.

Con mucho placer, Vezzani s.p.a. entrega esta certificación por escrito a su clientela, la cual le ha permitido, concediéndole su confianza, transformarse en la empresa líder en el mundo de este sector.

Con gratitud.





CREMA

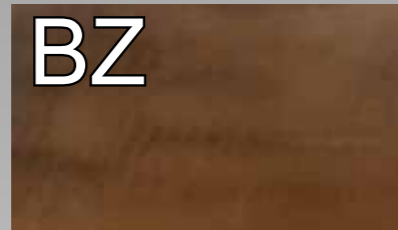

BRONZO

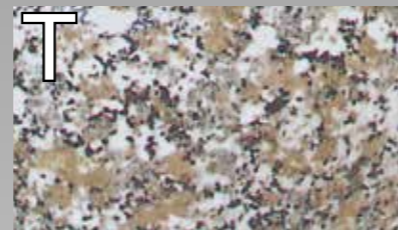

SARDINIA BETA



PORTOS



MELROSE



BETHEL WHITE



RIGEL



SAHARA

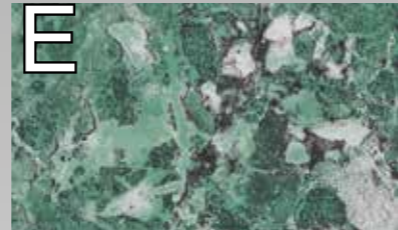

VERDE



SARDINIA



QUIN



TRAVERTINO



TRANI

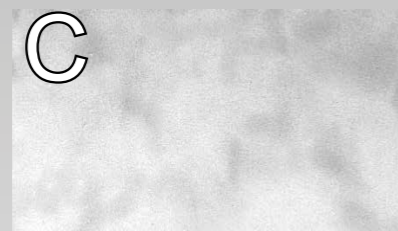

CARRARA



BLU

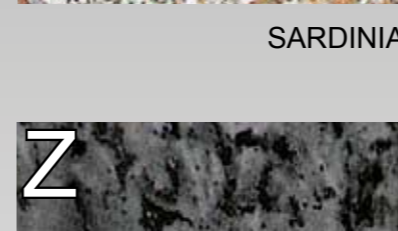

LABRADOR

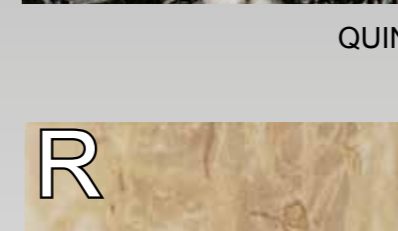

ROMA

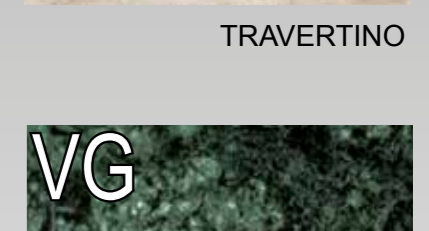

VERDE GUATEMALA



APUANIA



TURKEY



ALPI

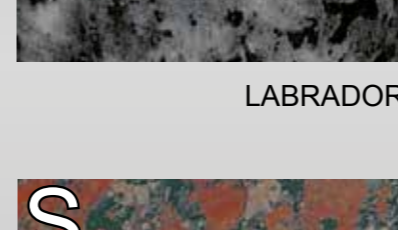

SIERRA

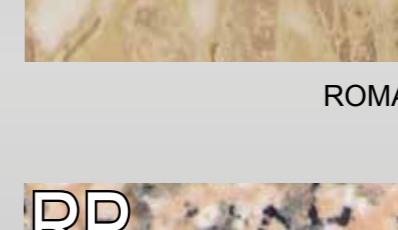

ROSA PORRINO

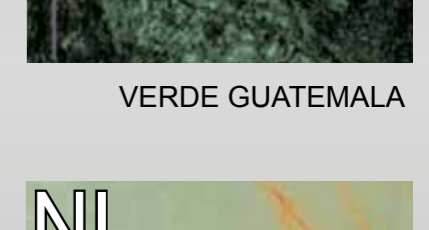

ONICE



ASPEN



PINK



AFRICA



SAHARA YELLOW



ROSA DEL PORTOGALLO

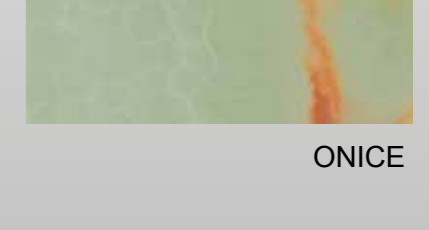

JAMAICA



RED

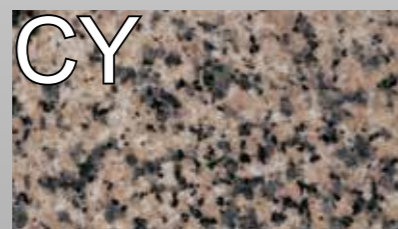

CAYMAN



ROSA BELLISSIMO



SAHARA YELLOW



ROSA DEL PORTOGALLO



JAMAICA



ROSA



CALIZIA

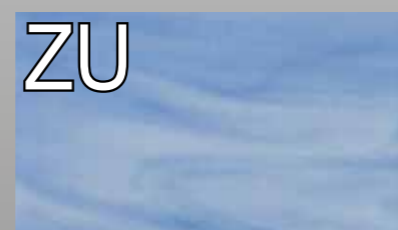

AZZURRO



VERONA

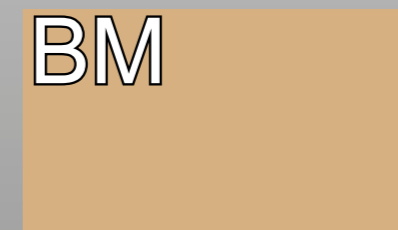

BRONZO METALLIZZATO



ART. 27420 P
↓ 21 ↔ 11 cm.

ART. 27421 I
↓ 21 ↔ 11 cm.

ART. 27283 P T
↓ 21 ↔ 11 cm.

ART. 27284 I
↓ 21 ↔ 11 cm.

ART. 27537 P
↓ 28 ↔ 16 cm.

ART. 27536 I
↓ 28 ↔ 16 cm.



ART. 27476 P P
↓ 11 ↔ 7 cm.

ART. 27624 P
↓ 13 ↔ 8 cm.

ART. 27623 R/C
↓ 13 ↔ 8 cm.

ART. 27579 P T
↓ 13 ↔ 8 cm.

ART. 27578 R/C
↓ 13 ↔ 8 cm.



ART. 29495 P P
↓ 18,5 ↔ 17 cm.

ART. 29496 R/C
↓ 18,5 ↔ 17 cm.

ART. 29606 P T
↓ 18,5 ↔ 17 cm.

ART. 29607 R/C
↓ 18,5 ↔ 17 cm.



ART. 29780 P T
interno alluminio
↓ 14,5 ↔ 18 cm.



ART. 26421 Ø 5 P
↓ 21 ↔ 8,5 cm.

ART. 26102 Ø 5 T
↓ 21 ↔ 8,5 cm.



ART. 26616 Ø 4 P
↓ 13 ↔ 7 cm.

ART. 26150 Ø 4 T
↓ 13 ↔ 7 cm.



ART. 20158 7x9 cm.
ART. 20159 8x10 cm.
ART. 20155 9x12 cm.
ART. 20156 11x15 cm.
ART. 20157 13x18 cm.



ART. 20166 9x12 cm.
ART. 20167 10x15 cm.
ART. 20168 11x15 cm.
ART. 20169 13x18 cm.



ART. 24025 ↓ 10 ↔ 6 cm.
ART. 24026 ↓ 15 ↔ 9 cm.
ART. 24027 ↓ 20 ↔ 11 cm.
ART. 24028 ↓ 30 ↔ 14 cm.
ART. 24029 ↓ 40 ↔ 15 cm.

Per ordinazioni aggiungere al codice articolo la lettera corrispondente alla colorazione scelta.
To place orders add to the article code the letter corresponding the selected colouring.

Si informa che la colorazione platino contiene particelle metalliche quindi potrebbe subire piccole alterazioni di colore nel tempo.
We inform you that platinum contains metal particles so it could change a little its colour in time.



- ART. 27420 P \updownarrow 21 \leftrightarrow 11 cm. P
- ART. 27283 P \updownarrow 21 \leftrightarrow 11 cm. T
- ART. 27421 I \updownarrow 21 \leftrightarrow 11 cm. □
- ART. 27284 I \updownarrow 21 \leftrightarrow 11 cm. □
- ART. 27537 P \updownarrow 28 \leftrightarrow 16 cm. □
- ART. 27536 I \updownarrow 28 \leftrightarrow 16 cm. □

- ART. 27422 P \updownarrow 21 \leftrightarrow 11 cm. P
- ART. 27286 P \updownarrow 21 \leftrightarrow 11 cm. T
- ART. 27423 I \updownarrow 21 \leftrightarrow 11 cm. □
- ART. 27287 I \updownarrow 21 \leftrightarrow 11 cm. □
- ART. 27549 P \updownarrow 28 \leftrightarrow 16 cm. □
- ART. 27548 I \updownarrow 28 \leftrightarrow 16 cm. □

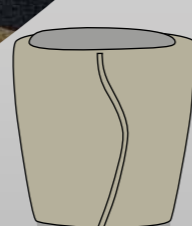

- ART. 29495 P \updownarrow 18,5 \leftrightarrow 17 cm. P
- ART. 29606 P \updownarrow 18,5 \leftrightarrow 17 cm. T
- ART. 26421 Ø 5 \updownarrow 21 \leftrightarrow 8,5 cm. P
- ART. 26616 Ø 4 \updownarrow 13 \leftrightarrow 7 cm. P
- ART. 29496 R/C \updownarrow 18,5 \leftrightarrow 17 cm. □
- ART. 29607 R/C \updownarrow 18,5 \leftrightarrow 17 cm. □
- ART. 26102 Ø 5 \updownarrow 21 \leftrightarrow 8,5 cm. T
- ART. 26150 Ø 4 \updownarrow 13 \leftrightarrow 7 cm. T



- ART. 26617 Ø 4 \updownarrow 13 \leftrightarrow 7 cm. P
- ART. 26423 Ø 5 \updownarrow 21 \leftrightarrow 8,5 cm. P
- ART. 29497 P \updownarrow 18,5 \leftrightarrow 17 cm. P
- ART. 29608 P \updownarrow 18,5 \leftrightarrow 17 cm. T
- ART. 26153 Ø 4 \updownarrow 13 \leftrightarrow 7 cm. T
- ART. 26104 Ø 5 \updownarrow 21 \leftrightarrow 8,5 cm. T
- ART. 29498 R/C \updownarrow 18,5 \leftrightarrow 17 cm. □
- ART. 29609 R/C \updownarrow 18,5 \leftrightarrow 17 cm. □

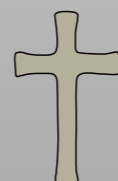
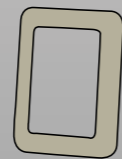
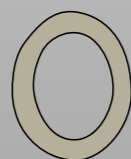

- ART. 27476 P \updownarrow 11 \leftrightarrow 7 cm. P
- ART. 27579 P \updownarrow 13 \leftrightarrow 8 cm. T
- ART. 20158 7x9 cm.
- ART. 20159 8x10 cm.
- ART. 20155 9x12 cm.
- ART. 20156 11x15 cm.
- ART. 20157 13x18 cm.
- ART. 27624 P \updownarrow 13 \leftrightarrow 8 cm. □
- ART. 27578 R/C \updownarrow 13 \leftrightarrow 8 cm. □
- ART. 20166 9x12 cm.
- ART. 20167 10x15 cm.
- ART. 20168 11x15 cm.
- ART. 20169 13x18 cm.
- ART. 24025 \updownarrow 10 \leftrightarrow 6 cm.
- ART. 24026 \updownarrow 15 \leftrightarrow 9 cm.
- ART. 24027 \updownarrow 20 \leftrightarrow 11 cm.
- ART. 24028 \updownarrow 30 \leftrightarrow 14 cm.
- ART. 24029 \updownarrow 40 \leftrightarrow 15 cm.



- ART. 27482 P \updownarrow 11 \leftrightarrow 7 cm. P
- ART. 27583 P \updownarrow 13 \leftrightarrow 8 cm. T
- ART. 200065 7x9 cm.
- ART. 200066 8x10 cm.
- ART. 200067 9x12 cm.
- ART. 200068 11x15 cm.
- ART. 200069 13x18 cm.
- ART. 27626 P \updownarrow 13 \leftrightarrow 8 cm. □
- ART. 27582 R/C \updownarrow 13 \leftrightarrow 8 cm. □
- ART. 200070 9x12 cm.
- ART. 200071 10x15 cm.
- ART. 200072 11x15 cm.
- ART. 200073 13x18 cm.
- ART. 24369 \updownarrow 10 \leftrightarrow 6 cm.
- ART. 24370 \updownarrow 15 \leftrightarrow 9 cm.
- ART. 24371 \updownarrow 20 \leftrightarrow 11 cm.
- ART. 24372 \updownarrow 30 \leftrightarrow 14 cm.
- ART. 24373 \updownarrow 40 \leftrightarrow 15 cm.

Per ordinazioni aggiungere al codice articolo la lettera corrispondente alla colorazione scelta.
To place orders add to the article code the letter corresponding the selected colouring.



ART. 27424 P
↓ 21 ↔ 11 cm.

ART. 27288 P
↓ 21 ↔ 11 cm.

ART. 27426 P
↓ 21 ↔ 11 cm.

ART. 27298 P
↓ 21 ↔ 11 cm.

ART. 27425 I
↓ 21 ↔ 11 cm.

ART. 27297 I
↓ 21 ↔ 11 cm.

ART. 27427 I
↓ 21 ↔ 11 cm.

ART. 27299 I
↓ 21 ↔ 11 cm.

ART. 27551 P
↓ 28 ↔ 16 cm.

ART. 27553 P
↓ 28 ↔ 16 cm.

ART. 27550 I
↓ 28 ↔ 16 cm.

ART. 27552 I
↓ 28 ↔ 16 cm.



ART. 29499 P
↓ 18,5 ↔ 17 cm.

ART. 29610 P
↓ 18,5 ↔ 17 cm.

ART. 26424 Ø 5
↓ 21 ↔ 8,5 cm.

ART. 26618 Ø 4
↓ 13 ↔ 7 cm.

ART. 26619 Ø 4
↓ 13 ↔ 7 cm.

ART. 26425 Ø 5
↓ 21 ↔ 8,5 cm.

ART. 29517 P
↓ 18,5 ↔ 17 cm.

ART. 29612 P
↓ 18,5 ↔ 17 cm.

ART. 29514 R/C
↓ 18,5 ↔ 17 cm.

ART. 29611 R/C
↓ 18,5 ↔ 17 cm.

ART. 26107 Ø 5
↓ 21 ↔ 8,5 cm.

ART. 26180 Ø 4
↓ 13 ↔ 7 cm.

ART. 26182 Ø 4
↓ 13 ↔ 7 cm.

ART. 26108 Ø 5
↓ 21 ↔ 8,5 cm.

ART. 29523 R/C
↓ 18,5 ↔ 17 cm.

ART. 29613 R/C
↓ 18,5 ↔ 17 cm.



ART. 27483 P
↓ 11 ↔ 7 cm.

ART. 27628 P
↓ 13 ↔ 8 cm.

ART. 27585 P
↓ 13 ↔ 8 cm.

ART. 200095 7x9 cm.
ART. 200096 8x10 cm.
ART. 200097 9x12 cm.
ART. 200098 11x15 cm.
ART. 200099 13x18 cm.

ART. 200100 9x12 cm.
ART. 200101 10x15 cm.
ART. 200102 11x15 cm.
ART. 200103 13x18 cm.

ART. 24364 ↓ 10 ↔ 6 cm.
ART. 24365 ↓ 15 ↔ 9 cm.
ART. 24366 ↓ 20 ↔ 11 cm.
ART. 24367 ↓ 30 ↔ 14 cm.
ART. 24368 ↓ 40 ↔ 15 cm.

ART. 27484 P
↓ 11 ↔ 7 cm.

ART. 27630 P
↓ 13 ↔ 8 cm.

ART. 27587 P
↓ 13 ↔ 8 cm.

ART. 200104 7x9 cm.
ART. 200105 8x10 cm.
ART. 200106 9x12 cm.
ART. 200059 11x15 cm.
ART. 200060 13x18 cm.

ART. 200061 9x12 cm.
ART. 200062 10x15 cm.
ART. 200063 11x15 cm.
ART. 200064 13x18 cm.

ART. 24000 ↓ 10 ↔ 6 cm.
ART. 24001 ↓ 15 ↔ 9 cm.
ART. 24034 ↓ 20 ↔ 11 cm.
ART. 24054 ↓ 30 ↔ 14 cm.
ART. 24363 ↓ 40 ↔ 15 cm.

Per ordinazioni aggiungere al codice articolo la lettera corrispondente alla colorazione scelta.

To place orders add to the article code the letter corresponding the selected colouring.



ART. 27449 P **P** ↓ 21 ↔ 11 cm.
ART. 27450 I ↓ 21 ↔ 11 cm.
ART. 27520 P **T** ↓ 21 ↔ 11 cm.
ART. 27521 I ↓ 21 ↔ 11 cm.
ART. 27535 P ↓ 28 ↔ 16 cm.
ART. 27534 I ↓ 28 ↔ 16 cm.

ART. 27449 P **P** ↓ 21 ↔ 11 cm.
ART. 27450 I ↓ 21 ↔ 11 cm.
ART. 27520 P **T** ↓ 21 ↔ 11 cm.
ART. 27521 I ↓ 21 ↔ 11 cm.
ART. 27535 P ↓ 28 ↔ 16 cm.
ART. 27534 I ↓ 28 ↔ 16 cm.

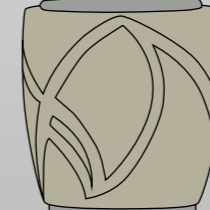

ART. 29556 P **P** ↓ 18,5 ↔ 17 cm.
ART. 29561 R/C ↓ 18,5 ↔ 17 cm.
ART. 29626 P **T** ↓ 18,5 ↔ 17 cm.
ART. 29627 R/C ↓ 18,5 ↔ 17 cm.
ART. 26438 Ø 5 **P** ↓ 21 ↔ 9 cm.
ART. 26115 Ø 5 **T** ↓ 21 ↔ 9 cm.
ART. 26601 Ø 4 **P** ↓ 13 ↔ 7,5 cm.
ART. 26144 Ø 4 **T** ↓ 13 ↔ 7,5 cm.
ART. 26601 Ø 4 **P** ↓ 13 ↔ 7,5 cm.
ART. 26438 Ø 5 **P** ↓ 21 ↔ 9 cm.
ART. 26115 Ø 5 **T** ↓ 21 ↔ 9 cm.
ART. 29556 P **P** ↓ 18,5 ↔ 17 cm.
ART. 29561 R/C ↓ 18,5 ↔ 17 cm.
ART. 29626 P **T** ↓ 18,5 ↔ 17 cm.
ART. 29627 R/C ↓ 18,5 ↔ 17 cm.

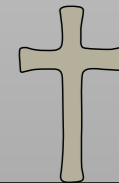
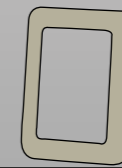
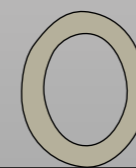

ART. 27475 P **P** ↓ 11 ↔ 7 cm.
ART. 27607 P ↓ 13 ↔ 8 cm.
ART. 27606 R/C ↓ 13 ↔ 8 cm.
ART. 27565 P **T** ↓ 13 ↔ 8 cm.
ART. 27564 R/C ↓ 13 ↔ 8 cm.
ART. 20158 7x9 cm.
ART. 20159 8x10 cm.
ART. 20155 9x12 cm.
ART. 20156 11x15 cm.
ART. 20157 13x18 cm.
ART. 20166 9x12 cm.
ART. 20167 10x15 cm.
ART. 20168 11x15 cm.
ART. 20169 13x18 cm.
ART. 24025 ↓ 10 ↔ 6 cm.
ART. 24026 ↓ 15 ↔ 9 cm.
ART. 24027 ↓ 20 ↔ 11 cm.
ART. 24028 ↓ 30 ↔ 14 cm.
ART. 24029 ↓ 40 ↔ 15 cm.
ART. 27475 P **P** ↓ 11 ↔ 7 cm.
ART. 27607 P ↓ 13 ↔ 8 cm.
ART. 27606 R/C ↓ 13 ↔ 8 cm.
ART. 27565 P **T** ↓ 13 ↔ 8 cm.
ART. 27564 R/C ↓ 13 ↔ 8 cm.
ART. 20158 7x9 cm.
ART. 20159 8x10 cm.
ART. 20155 9x12 cm.
ART. 20156 11x15 cm.
ART. 20157 13x18 cm.
ART. 20166 9x12 cm.
ART. 20167 10x15 cm.
ART. 20168 11x15 cm.
ART. 20169 13x18 cm.
ART. 24025 ↓ 10 ↔ 6 cm.
ART. 24026 ↓ 15 ↔ 9 cm.
ART. 24027 ↓ 20 ↔ 11 cm.
ART. 24028 ↓ 30 ↔ 14 cm.
ART. 24029 ↓ 40 ↔ 15 cm.

Si informa che la colorazione platino contiene particelle metalliche quindi potrebbe subire piccole alterazioni di colore nel tempo.

We inform you that platinum contains metal particles so it could change a little its colour in time.

Per ordinazioni aggiungere al codice articolo la lettera corrispondente alla colorazione scelta.

To place orders add to the article code the letter corresponding the selected colouring.



ART. 27451 P **P** ↓ 21 ↔ 11 cm.
 ART. 27452 I ↓ 21 ↔ 11 cm.
 ART. 27522 P **T** ↓ 21 ↔ 11 cm.
 ART. 27523 I ↓ 21 ↔ 11 cm.
 ART. 27539 P ↓ 28 ↔ 16 cm.
 ART. 27538 I ↓ 28 ↔ 16 cm.

ART. 27461 P **P** ↓ 21 ↔ 11 cm.
 ART. 27466 I ↓ 21 ↔ 11 cm.
 ART. 27526 P **T** ↓ 21 ↔ 11 cm.
 ART. 27527 I ↓ 21 ↔ 11 cm.
 ART. 27543 P ↓ 28 ↔ 16 cm.
 ART. 27542 I ↓ 28 ↔ 16 cm.

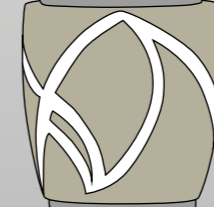

ART. 29564 P **P** ↓ 18,5 ↔ 17 cm.
 ART. 29565 R/C ↓ 18,5 ↔ 17 cm.
 ART. 29628 P **T** ↓ 18,5 ↔ 17 cm.
 ART. 29629 R/C ↓ 18,5 ↔ 17 cm.

ART. 26439 Ø 5 **P** ↓ 21 ↔ 9 cm.
 ART. 26603 Ø 4 **P** ↓ 13 ↔ 7,5 cm.
 ART. 26117 Ø 5 **T** ↓ 21 ↔ 9 cm.
 ART. 26145 Ø 4 **T** ↓ 13 ↔ 7,5 cm.

ART. 26612 Ø 4 **P** ↓ 13 ↔ 7,5 cm.
 ART. 26147 Ø 4 **T** ↓ 13 ↔ 7,5 cm.
 ART. 26441 Ø 5 **P** ↓ 21 ↔ 9 cm.
 ART. 26120 Ø 5 **T** ↓ 21 ↔ 9 cm.
 ART. 29568 P **P** ↓ 18,5 ↔ 17 cm.
 ART. 29569 R/C ↓ 18,5 ↔ 17 cm.
 ART. 29633 P **T** ↓ 18,5 ↔ 17 cm.
 ART. 29634 R/C ↓ 18,5 ↔ 17 cm.

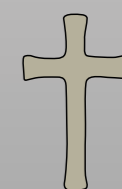
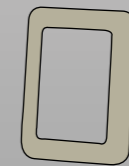
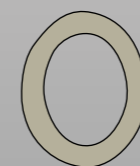

ART. 27477 P **P** ↓ 11 ↔ 7 cm.
 ART. 27612 P ↓ 13 ↔ 8 cm.
 ART. 27609 R/C ↓ 13 ↔ 8 cm.
 ART. 27569 P **T** ↓ 13 ↔ 8 cm.
 ART. 27568 R/C ↓ 13 ↔ 8 cm.
 ART. 200065 7x9 cm.
 ART. 200066 8x10 cm.
 ART. 200067 9x12 cm.
 ART. 200068 11x15 cm.
 ART. 200069 13x18 cm.

ART. 200070 9x12 cm.
 ART. 200071 10x15 cm.
 ART. 200072 11x15 cm.
 ART. 200073 13x18 cm.

ART. 24369 ↓ 10 ↔ 6 cm.
 ART. 24370 ↓ 15 ↔ 9 cm.
 ART. 24371 ↓ 20 ↔ 11 cm.
 ART. 24372 ↓ 30 ↔ 14 cm.
 ART. 24373 ↓ 40 ↔ 15 cm.

ART. 27479 P **P** ↓ 11 ↔ 7 cm.
 ART. 27618 P ↓ 13 ↔ 8 cm.
 ART. 27617 R/C ↓ 13 ↔ 8 cm.
 ART. 27573 P **T** ↓ 13 ↔ 8 cm.
 ART. 27572 R/C ↓ 13 ↔ 8 cm.

ART. 20158 7x9 cm.
 ART. 20159 8x10 cm.
 ART. 20155 9x12 cm.
 ART. 20156 11x15 cm.
 ART. 20157 13x18 cm.

ART. 20166 9x12 cm.
 ART. 20167 10x15 cm.
 ART. 20168 11x15 cm.
 ART. 20169 13x18 cm.

ART. 24025 ↓ 10 ↔ 6 cm.
 ART. 24026 ↓ 15 ↔ 9 cm.
 ART. 24027 ↓ 20 ↔ 11 cm.
 ART. 24028 ↓ 30 ↔ 14 cm.
 ART. 24029 ↓ 40 ↔ 15 cm.



ART. 27471 P
↓ 21 ↔ 11 cm.

ART. 27530 P
↓ 21 ↔ 11 cm.

ART. 27473 I
↓ 21 ↔ 11 cm.

ART. 27531 I
↓ 21 ↔ 11 cm.

ART. 27545 P
↓ 28 ↔ 16 cm.

ART. 27544 I
↓ 28 ↔ 16 cm.

ART. 27467 P
↓ 21 ↔ 11 cm.

ART. 27528 P
↓ 21 ↔ 11 cm.

ART. 27470 I
↓ 21 ↔ 11 cm.

ART. 27529 I
↓ 21 ↔ 11 cm.

ART. 27547 P
↓ 28 ↔ 16 cm.

ART. 27546 I
↓ 28 ↔ 16 cm.



ART. 29572 P
↓ 18,5 ↔ 17 cm.

ART. 29637 P
↓ 18,5 ↔ 17 cm.

ART. 26443 Ø 5
↓ 21 ↔ 9 cm.

ART. 26613 Ø 4
↓ 13 ↔ 7,5 cm.

ART. 26614 Ø 4
↓ 13 ↔ 7,5 cm.

ART. 26442 Ø 5
↓ 21 ↔ 9 cm.

ART. 29570 P
↓ 18,5 ↔ 17 cm.

ART. 29635 P
↓ 18,5 ↔ 17 cm.

ART. 29573 R/C
↓ 18,5 ↔ 17 cm.

ART. 29638 R/C
↓ 18,5 ↔ 17 cm.

ART. 26123 Ø 5
↓ 21 ↔ 9 cm.

ART. 26148 Ø 4
↓ 13 ↔ 7,5 cm.

ART. 26149 Ø 4
↓ 13 ↔ 7,5 cm.

ART. 26121 Ø 5
↓ 21 ↔ 9 cm.

ART. 29571 R/C
↓ 18,5 ↔ 17 cm.

ART. 29636 R/C
↓ 18,5 ↔ 17 cm.



ART. 27480 P
↓ 11 ↔ 7 cm.

ART. 27620 P
↓ 13 ↔ 8 cm.

ART. 27619 R/C
↓ 13 ↔ 8 cm.

ART. 27575 P
↓ 13 ↔ 8 cm.

ART. 27574 R/C
↓ 13 ↔ 8 cm.

ART. 200104 7x9 cm.
ART. 200105 8x10 cm.
ART. 200106 9x12 cm.
ART. 200059 11x15 cm.
ART. 200060 13x18 cm.

ART. 200061 9x12 cm.
ART. 200062 10x15 cm.
ART. 200063 11x15 cm.
ART. 200064 13x18 cm.

ART. 24000 ↓ 10 ↔ 6 cm.
ART. 24001 ↓ 15 ↔ 9 cm.
ART. 24034 ↓ 20 ↔ 11 cm.
ART. 24054 ↓ 30 ↔ 14 cm.
ART. 24363 ↓ 40 ↔ 15 cm.

ART. 27481 P
↓ 11 ↔ 7 cm.

ART. 27622 P
↓ 13 ↔ 8 cm.

ART. 27621 R/C
↓ 13 ↔ 8 cm.

ART. 27577 P
↓ 13 ↔ 8 cm.

ART. 27576 R/C
↓ 13 ↔ 8 cm.

ART. 200095 7x9 cm.
ART. 200096 8x10 cm.
ART. 200097 9x12 cm.
ART. 200098 11x15 cm.
ART. 200099 13x18 cm.

ART. 200100 9x12 cm.
ART. 200101 10x15 cm.
ART. 200102 11x15 cm.
ART. 200103 13x18 cm.

ART. 24364 ↓ 10 ↔ 6 cm.
ART. 24365 ↓ 15 ↔ 9 cm.
ART. 24366 ↓ 20 ↔ 11 cm.
ART. 24367 ↓ 30 ↔ 14 cm.
ART. 24368 ↓ 40 ↔ 15 cm.



ART. 27428 P
↓ 21 ↔ 11 cm.

ART. 27429 I
↓ 21 ↔ 11 cm.

ART. 27506 P
↓ 21 ↔ 11 cm.

ART. 27507 I
↓ 21 ↔ 11 cm.

ART. 27533 P
↓ 28 ↔ 16 cm.

ART. 27532 I
↓ 28 ↔ 16 cm.



ART. 27474 P
↓ 11 ↔ 7 cm.

ART. 27632 P
↓ 13 ↔ 8 cm.
ART. 27631 R/C
↓ 13 ↔ 8 cm.

ART. 27589 P
↓ 13 ↔ 8 cm.

ART. 27588 R/C
↓ 13 ↔ 8 cm.



ART. 29526 P
↓ 18,5 ↔ 17 cm.

ART. 29533 R/C
↓ 18,5 ↔ 17 cm.

ART. 29614 P
↓ 18,5 ↔ 17 cm.

ART. 29615 R/C
↓ 18,5 ↔ 17 cm.



ART. 29781 P
int. alluminio
↓ 14,5 ↔ 19 cm.



ART. 26426 Ø 5
↓ 21 ↔ 9 cm.

ART. 26109 Ø 5
↓ 21 ↔ 9 cm.



ART. 26620 Ø 4
↓ 13 ↔ 7 cm.

ART. 26184 Ø 4
↓ 13 ↔ 7 cm.



Art. 20665 9x12 cm.
Art. 20666 11x15 cm.
Art. 20667 13x18 cm.



Art. 20668 9x12 cm.
Art. 20669 10x15 cm.
Art. 20670 11x15 cm.
Art. 20671 13x18 cm.



Art. 24322 ↓ 20 ↔ 11 cm.

Per ordinazioni aggiungere al codice articolo la lettera corrispondente alla colorazione scelta.
To place orders add to the article code the letter corresponding the selected colouring.

Si informa che la colorazione platino contiene particelle metalliche quindi potrebbe subire piccole alterazioni di colore nel tempo.
We inform you that platinum contains metal particles so it could change a little its colour in time.



ART. 27428 P
↓ 21 ↔ 11 cm.

ART. 27506 P
↓ 21 ↔ 11 cm.

ART. 27439 P
↓ 21 ↔ 11 cm.

ART. 27508 P
↓ 21 ↔ 11 cm.

ART. 27429 I
↓ 21 ↔ 11 cm.

ART. 27507 I
↓ 21 ↔ 11 cm.

ART. 27440 I
↓ 21 ↔ 11 cm.

ART. 27509 I
↓ 21 ↔ 11 cm.

ART. 27533 P
↓ 28 ↔ 16 cm.

ART. 27555 P
↓ 28 ↔ 16 cm.

ART. 27532 I
↓ 28 ↔ 16 cm.

ART. 27554 I
↓ 28 ↔ 16 cm.



ART. 29526 P
↓ 18,5 ↔ 17 cm.

ART. 29614 P
↓ 18,5 ↔ 17 cm.

ART. 26426 Ø 5
↓ 21 ↔ 9 cm.

ART. 26620 Ø 4
↓ 13 ↔ 7 cm.

ART. 26621 Ø 4
↓ 13 ↔ 7 cm.

ART. 26427 Ø 5
↓ 21 ↔ 9 cm.

ART. 29534 P
↓ 18,5 ↔ 17 cm.

ART. 29616 P
↓ 18,5 ↔ 17 cm.

ART. 29533 R/C
↓ 18,5 ↔ 17 cm.

ART. 29615 R/C
↓ 18,5 ↔ 17 cm.

ART. 26109 Ø 5
↓ 21 ↔ 9 cm.

ART. 26184 Ø 4
↓ 13 ↔ 7 cm.

ART. 26297 Ø 4
↓ 13 ↔ 7 cm.

ART. 26110 Ø 5
↓ 21 ↔ 9 cm.

ART. 29535 R/C
↓ 18,5 ↔ 17 cm.

ART. 29617 R/C
↓ 18,5 ↔ 17 cm.

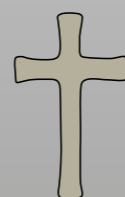

ART. 27474 P
↓ 11 ↔ 7 cm.
ART. 27632 P
↓ 13 ↔ 8 cm.
ART. 27631 R/C
↓ 13 ↔ 8 cm.

ART. 27589 P
↓ 13 ↔ 8 cm.
ART. 27588 R/C
↓ 13 ↔ 8 cm.

Art. 20665 9x12 cm.
Art. 20666 11x15 cm.
Art. 20667 13x18 cm.

Art. 20668 9x12 cm.
Art. 20669 10x15 cm.
Art. 20670 11x15 cm.
Art. 20671 13x18 cm.

Art. 24322 ↓ 20 ↔ 11 cm.

ART. 27485 P
↓ 11 ↔ 7 cm.
ART. 27634 P
↓ 13 ↔ 8 cm.
ART. 27633 R/C
↓ 13 ↔ 8 cm.

ART. 27593 P
↓ 13 ↔ 8 cm.
ART. 27592 R/C
↓ 13 ↔ 8 cm.

Art. 200088 9x12 cm.
Art. 200089 11x15 cm.
Art. 200090 13x18 cm.

Art. 200091 9x12 cm.
Art. 200092 10x15 cm.
Art. 200093 11x15 cm.
Art. 200094 13x18 cm.

Art. 24377 ↓ 20 ↔ 11 cm.

Per ordinazioni aggiungere al codice articolo la lettera corrispondente alla colorazione scelta.

To place orders add to the article code the letter corresponding the selected colouring.

Per ordinazioni aggiungere al codice articolo la lettera corrispondente alla colorazione scelta.

To place orders add to the article code the letter corresponding the selected colouring.



ART. 27443 P
↓ 21 ↔ 11 cm.

ART. 27514 P
↓ 21 ↔ 11 cm.

ART. 27445 P
↓ 21 ↔ 11 cm.

ART. 27516 P
↓ 21 ↔ 11 cm.

ART. 27444 I
↓ 21 ↔ 11 cm.

ART. 27515 I
↓ 21 ↔ 11 cm.

ART. 27446 I
↓ 21 ↔ 11 cm.

ART. 27517 I
↓ 21 ↔ 11 cm.

ART. 27557 P
↓ 28 ↔ 16 cm.

ART. 27559 P
↓ 28 ↔ 16 cm.

ART. 27556 I
↓ 28 ↔ 16 cm.

ART. 27558 I
↓ 28 ↔ 16 cm.



ART. 29541 P
↓ 18,5 ↔ 17 cm.

ART. 29620 P
↓ 18,5 ↔ 17 cm.

ART. 26429 Ø 5
↓ 21 ↔ 9 cm.

ART. 26622 Ø 4
↓ 13 ↔ 7 cm.

ART. 26623 Ø 4
↓ 13 ↔ 7 cm.

ART. 26431 Ø 5
↓ 21 ↔ 9 cm.

ART. 29551 P
↓ 18,5 ↔ 17 cm.

ART. 29622 P
↓ 18,5 ↔ 17 cm.

ART. 29550 R/C
↓ 18,5 ↔ 17 cm.

ART. 29621 R/C
↓ 18,5 ↔ 17 cm.

ART. 26112 Ø 5
↓ 21 ↔ 9 cm.

ART. 26298 Ø 4
↓ 13 ↔ 7 cm.

ART. 26299 Ø 4
↓ 13 ↔ 7 cm.

ART. 26113 Ø 5
↓ 21 ↔ 9 cm.

ART. 29552 R/C
↓ 18,5 ↔ 17 cm.

ART. 29623 R/C
↓ 18,5 ↔ 17 cm.

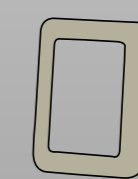
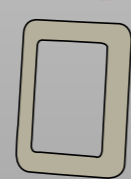

ART. 27486 P
↓ 11 ↔ 7 cm.

ART. 27595 P
↓ 13 ↔ 8 cm.

Art. 20665 9x12 cm.
Art. 20666 11x15 cm.
Art. 20667 13x18 cm.

Art. 20668 9x12 cm.
Art. 20669 10x15 cm.
Art. 20670 11x15 cm.
Art. 20671 13x18 cm.

Art. 24322 ↓ 20 ↔ 11 cm.

ART. 27487 P
↓ 11 ↔ 7 cm.

ART. 27638 P
↓ 13 ↔ 8 cm.

Art. 20665 9x12 cm.
Art. 20666 11x15 cm.
Art. 20667 13x18 cm.

Art. 20668 9x12 cm.
Art. 20669 10x15 cm.
Art. 20670 11x15 cm.
Art. 20671 13x18 cm.

Art. 24322 ↓ 20 ↔ 11 cm.

ART. 27597 P
↓ 13 ↔ 8 cm.

ART. 27637 R/C
↓ 13 ↔ 8 cm.

ART. 27596 R/C
↓ 13 ↔ 8 cm.

ART. 27637 R/C
↓ 13 ↔ 8 cm.



ART. 27447 P
↓ 21 ↔ 11 cm.

ART. 27518 P
↓ 21 ↔ 11 cm.

ART. 27448 I
↓ 21 ↔ 11 cm.

ART. 27519 I
↓ 21 ↔ 11 cm.

ART. 27561 P
↓ 28 ↔ 16 cm.

ART. 27560 I
↓ 28 ↔ 16 cm.

ART. 27441 P
↓ 21 ↔ 11 cm.

ART. 27512 P
↓ 21 ↔ 11 cm.

ART. 27442 I
↓ 21 ↔ 11 cm.

ART. 27513 I
↓ 21 ↔ 11 cm.

ART. 27563 P
↓ 28 ↔ 16 cm.

ART. 27562 I
↓ 28 ↔ 16 cm.



ART. 29553 P
↓ 18,5 ↔ 17 cm.

ART. 29624 P
↓ 18,5 ↔ 17 cm.

ART. 26437 Ø 5
↓ 21 ↔ 9 cm.

ART. 26624 Ø 4
↓ 13 ↔ 7 cm.

ART. 26625 Ø 4
↓ 13 ↔ 7 cm.

ART. 26428 Ø 5
↓ 21 ↔ 9 cm.

ART. 29539 P
↓ 18,5 ↔ 17 cm.

ART. 29618 P
↓ 18,5 ↔ 17 cm.

ART. 29554 R/C
↓ 18,5 ↔ 17 cm.

ART. 29625 R/C
↓ 18,5 ↔ 17 cm.

ART. 26114 Ø 5
↓ 21 ↔ 9 cm.

ART. 26502 Ø 4
↓ 13 ↔ 7 cm.

ART. 26504 Ø 4
↓ 13 ↔ 7 cm.

ART. 26111 Ø 5
↓ 21 ↔ 9 cm.

ART. 29540 R/C
↓ 18,5 ↔ 17 cm.

ART. 29619 R/C
↓ 18,5 ↔ 17 cm.



ART. 27488 P
↓ 11 ↔ 7 cm.
ART. 27640 P
↓ 13 ↔ 8 cm.
ART. 27639 R/C
↓ 13 ↔ 8 cm.

ART. 27599 P
↓ 13 ↔ 8 cm.
ART. 27598 R/C
↓ 13 ↔ 8 cm.

Art. 200074 9x12 cm.
Art. 200075 11x15 cm.
Art. 200076 13x18 cm.

Art. 200077 9x12 cm.
Art. 200078 10x15 cm.
Art. 200079 11x15 cm.
Art. 200080 13x18 cm.

Art. 24375 ↓ 20 ↔ 11 cm.

ART. 27489 P
↓ 11 ↔ 7 cm.
ART. 27642 P
↓ 13 ↔ 8 cm.
ART. 27641 R/C
↓ 13 ↔ 8 cm.

ART. 27581 P
↓ 13 ↔ 8 cm.
ART. 27580 R/C
↓ 13 ↔ 8 cm.

Art. 200081 9x12 cm.
Art. 200082 11x15 cm.
Art. 200083 13x18 cm.

Art. 200084 9x12 cm.
Art. 200085 10x15 cm.
Art. 200086 11x15 cm.
Art. 200087 13x18 cm.

Art. 24376 ↓ 20 ↔ 11 cm.

Per ordinazioni aggiungere al codice articolo la lettera corrispondente alla colorazione scelta.
To place orders add to the article code the letter corresponding the selected colouring.



ART. 27410 P
↓ 20 ↔ 12,5 cm.

ART. 27262 P T
↓ 20 ↔ 12,5 cm.

ART. 27410 P P
↓ 20 ↔ 12,5 cm.

ART. 27262 P T
↓ 20 ↔ 12,5 cm.

ART. 27411 I
↓ 20 ↔ 12,5 cm.

ART. 27263 I
↓ 20 ↔ 12,5 cm.

ART. 27411 I
↓ 20 ↔ 12,5 cm.

ART. 27263 I
↓ 20 ↔ 12,5 cm.



ART. 29390 P P
↓ 18 ↔ 17 cm.

ART. 29590 P T
↓ 18 ↔ 17 cm.

ART. 26415 Ø 5 P
↓ 21 ↔ 9,5 cm.

ART. 26415 Ø 5 P
↓ 21 ↔ 9,5 cm.

ART. 29390 P P
↓ 18 ↔ 17 cm.

ART. 29590 P T
↓ 18 ↔ 17 cm.

ART. 29399 R/C
↓ 18 ↔ 17 cm.

ART. 29591 R/C
↓ 18 ↔ 17 cm.

ART. 26162 Ø 5 T
↓ 21 ↔ 9,5 cm.

ART. 26162 Ø 5 T
↓ 21 ↔ 9,5 cm.

ART. 29399 R/C
↓ 18 ↔ 17 cm.

ART. 29591 R/C
↓ 18 ↔ 17 cm.

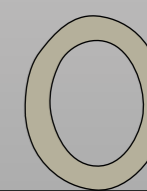
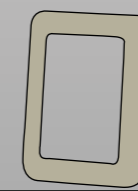
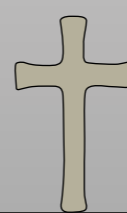

ART. 20153 7x9 cm.
ART. 20154 8x10 cm.
ART. 20263 9x12 cm.
ART. 20264 11x15 cm.
ART. 20265 13x18 cm.

ART. 20323 7x9 cm.
ART. 20324 8x10 cm.
ART. 20345 9x12 cm.
ART. 20346 10x15 cm.
ART. 20347 11x15 cm.
ART. 20348 13x18 cm.

ART. 24195 ↓ 10 ↔ 6 cm.
ART. 24196 ↓ 15 ↔ 9 cm.
ART. 24197 ↓ 20 ↔ 11 cm.
ART. 24198 ↓ 30 ↔ 14 cm.
ART. 24199 ↓ 40 ↔ 15 cm.

ART. 24195 ↓ 10 ↔ 6 cm.
ART. 24196 ↓ 15 ↔ 9 cm.
ART. 24197 ↓ 20 ↔ 11 cm.
ART. 24198 ↓ 30 ↔ 14 cm.
ART. 24199 ↓ 40 ↔ 15 cm.

ART. 20323 7x9 cm.
ART. 20324 8x10 cm.
ART. 20345 9x12 cm.
ART. 20346 10x15 cm.
ART. 20347 11x15 cm.
ART. 20348 13x18 cm.

ART. 20153 7x9 cm.
ART. 20154 8x10 cm.
ART. 20263 9x12 cm.
ART. 20264 11x15 cm.
ART. 20265 13x18 cm.

Per ordinazioni aggiungere al codice articolo la lettera corrispondente alla colorazione scelta.

To place orders add to the article code the letter corresponding the selected colouring.

Per ordinazioni aggiungere al codice articolo la lettera corrispondente alla colorazione scelta.

To place orders add to the article code the letter corresponding the selected colouring.



ART. 27414 P
↓ 20 ↔ 12,5 cm.

ART. 27266 P
↓ 20 ↔ 12,5 cm.

ART. 27412 P
↓ 20 ↔ 12,5 cm.

ART. 27264 P
↓ 20 ↔ 12,5 cm.

ART. 27415 I
↓ 20 ↔ 12,5 cm.

ART. 27267 I
↓ 20 ↔ 12,5 cm.

ART. 27413 I
↓ 20 ↔ 12,5 cm.

ART. 27265 I
↓ 20 ↔ 12,5 cm.

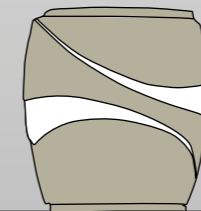
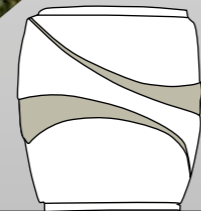

ART. 29487 P
↓ 18 ↔ 17 cm.

ART. 29588 P
↓ 18 ↔ 17 cm.

ART. 26417 Ø 5
↓ 21 ↔ 9,5 cm.

ART. 26416 Ø 5
↓ 21 ↔ 9,5 cm.

ART. 29489 P
↓ 18 ↔ 17 cm.

ART. 29586 P
↓ 18 ↔ 17 cm.

ART. 29488 R/C
↓ 18 ↔ 17 cm.

ART. 29589 R/C
↓ 18 ↔ 17 cm.

ART. 26172 Ø 5
↓ 21 ↔ 9,5 cm.

ART. 26163 Ø 5
↓ 21 ↔ 9,5 cm.

ART. 29490 R/C
↓ 18 ↔ 17 cm.

ART. 29587 R/C
↓ 18 ↔ 17 cm.

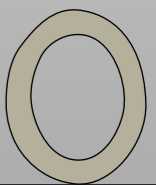
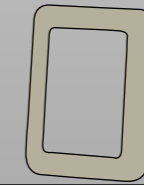
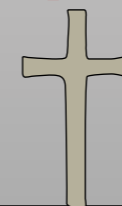
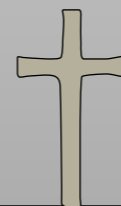
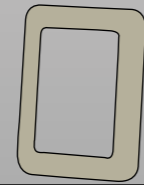
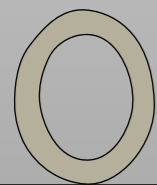

ART. 20153 7x9 cm.
ART. 20154 8x10 cm.
ART. 20263 9x12 cm.
ART. 20264 11x15 cm.
ART. 20265 13x18 cm.

ART. 20323 7x9 cm.
ART. 20324 8x10 cm.
ART. 20345 9x12 cm.
ART. 20346 10x15 cm.
ART. 20347 11x15 cm.
ART. 20348 13x18 cm.

ART. 24195 ↓ 10 ↔ 6 cm.
ART. 24196 ↓ 15 ↔ 9 cm.
ART. 24197 ↓ 20 ↔ 11 cm.
ART. 24198 ↓ 30 ↔ 14 cm.
ART. 24199 ↓ 40 ↔ 15 cm.

ART. 24195 ↓ 10 ↔ 6 cm.
ART. 24196 ↓ 15 ↔ 9 cm.
ART. 24197 ↓ 20 ↔ 11 cm.
ART. 24198 ↓ 30 ↔ 14 cm.
ART. 24199 ↓ 40 ↔ 15 cm.

ART. 20323 7x9 cm.
ART. 20324 8x10 cm.
ART. 20345 9x12 cm.
ART. 20346 10x15 cm.
ART. 20347 11x15 cm.
ART. 20348 13x18 cm.

ART. 20153 7x9 cm.
ART. 20154 8x10 cm.
ART. 20263 9x12 cm.
ART. 20264 11x15 cm.
ART. 20265 13x18 cm.



ART. 27122 P T
↓ 29 ↔ 17 cm.
ART. 27123 R/C
↓ 29 ↔ 17 cm.



ART. 27331 P P **ART. 27136 P** T
↓ 21 ↔ 12 cm. ↓ 21 ↔ 12 cm.
ART. 27332 R **ART. 27151 R**
↓ 21 ↔ 12 cm. ↓ 21 ↔ 12 cm.



ART. 27337 P P **ART. 27152 P** T
↓ 13,5 ↔ 9 cm. ↓ 13,5 ↔ 9 cm.
ART. 27336 R/C **ART. 27153 R/C**
↓ 13,5 ↔ 9 cm. ↓ 13,5 ↔ 9 cm.



ART. 27344 P P
↓ 11 ↔ 7 cm.



ART. 29476 P P **ART. 29199 P** T
↓ 19 ↔ 16,5 cm. ↓ 19 ↔ 16,5 cm.
ART. 29477 R/C **ART. 29200 R/C**
↓ 19 ↔ 16,5 cm. ↓ 19 ↔ 16,5 cm.



mezza vaschetta **ART. 29486 P** P
↓ 19 ↔ 19 cm.



mezza lampada **ART. 26486 Ø 5** P
↓ 20,5 ↔ 10,5 cm.



ART. 26344 Ø 4 P
↓ 12,5 ↔ 6,5 cm.



ART. 26122 Ø 6 T
↓ 27,5 ↔ 11,5 cm.



ART. 26315 Ø 5 P **ART. 26136 Ø 5** T
↓ 20 ↔ 9,5 cm. ↓ 20 ↔ 9,5 cm.



ART. 26336 Ø 4 P **ART. 26152 Ø 4** T
↓ 15 ↔ 7,5 cm. ↓ 15 ↔ 7,5 cm.



ART. 26974 P **ART. 26874** T
↓ 17,5 ↔ 14 cm. ↓ 17,5 ↔ 14 cm.
ART. 26875
↓ 22,5 ↔ 16 cm.



ART. 20153 7x9 cm.
ART. 20154 8x10 cm.
ART. 20263 9x12 cm.
ART. 20264 11x15 cm.
ART. 20265 13x18 cm.



ART. 20323 7x9 cm.
ART. 20324 8x10 cm.
ART. 20345 9x12 cm.
ART. 20346 10x15 cm.
ART. 20347 11x15 cm.
ART. 20348 13x18 cm.



ART. 20898 9x12 cm.
ART. 20899 11x15 cm.
ART. 20900 13x18 cm.



ART. 20901 9x12 cm.
ART. 20902 10x15 cm.
ART. 20909 11x15 cm.
ART. 20910 13x18 cm.



ART. 24195 ↓ 10 ↔ 6 cm.
ART. 24196 ↓ 15 ↔ 9 cm.
ART. 24197 ↓ 20 ↔ 11 cm.
ART. 24198 ↓ 30 ↔ 14 cm.
ART. 24199 ↓ 40 ↔ 15 cm.

Per ordinazioni aggiungere al codice articolo la lettera corrispondente alla colorazione scelta.

To place orders add to the article code the letter corresponding the selected colouring.



ART. 27331 P
↓ 21 ↔ 12 cm.

ART. 27332 R
↓ 21 ↔ 12 cm.

ART. 27337 P
↓ 13,5 ↔ 9 cm.

ART. 27336 R/C
↓ 13,5 ↔ 9 cm.

ART. 27344 P
↓ 11 ↔ 7 cm.

ART. 27122 P T
↓ 29 ↔ 17 cm.

ART. 27123 R/C
↓ 29 ↔ 17 cm.

ART. 27136 P
↓ 21 ↔ 12 cm.

ART. 27151 R
↓ 21 ↔ 12 cm.

ART. 27152 P
↓ 13,5 ↔ 9 cm.

ART. 27153 R/C
↓ 13,5 ↔ 9 cm.

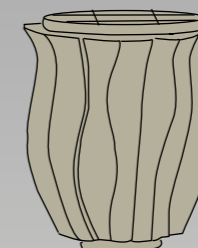

ART. 29476 P
↓ 19 ↔ 16,5 cm.

ART. 29477 R/C
↓ 19 ↔ 16,5 cm.

ART. 29199 P T
↓ 19 ↔ 16,5 cm.

ART. 29200 R/C
↓ 19 ↔ 16,5 cm.

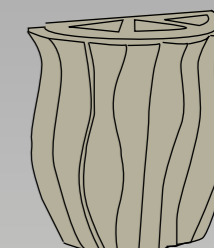

mezza vaschetta P
ART. 29486 P
↓ 19 ↔ 19 cm.



ART. 26315 Ø 5 P
↓ 20 ↔ 9,5 cm.

ART. 26336 Ø 4
↓ 15 ↔ 7,5 cm.

ART. 26344 Ø 4
↓ 12,5 ↔ 6,5 cm.

ART. 26122 Ø 6 T
↓ 27,5 ↔ 11,5 cm.

ART. 26136 Ø 5
↓ 20 ↔ 9,5 cm.

ART. 26152 Ø 4
↓ 15 ↔ 7,5 cm.



mezza lampada P
ART. 26486 Ø 5
↓ 20,5 ↔ 10,5 cm.



ART. 26974 P
↓ 17,5 ↔ 14 cm.

ART. 26874 T
↓ 17,5 ↔ 14 cm.

ART. 26875
↓ 22,5 ↔ 16 cm.



ART. 20153 7x9 cm.
ART. 20154 8x10 cm.
ART. 20263 9x12 cm.
ART. 20264 11x15 cm.
ART. 20265 13x18 cm.

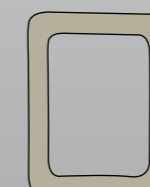

ART. 20323 7x9 cm.
ART. 20324 8x10 cm.
ART. 20345 9x12 cm.
ART. 20346 10x15 cm.
ART. 20347 11x15 cm.
ART. 20348 13x18 cm.

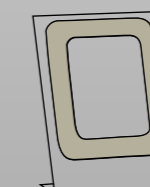

ART. 20901 9x12 cm.
ART. 20902 10x15 cm.
ART. 20909 11x15 cm.
ART. 20910 13x18 cm.

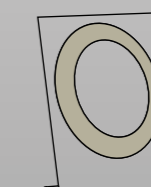

ART. 20898 9x12 cm.
ART. 20899 11x15 cm.
ART. 20900 13x18 cm.

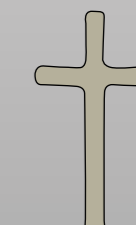

ART. 24195
↓ 10 ↔ 6 cm.
ART. 24196
↓ 15 ↔ 9 cm.
ART. 24197
↓ 20 ↔ 11 cm.
ART. 24198
↓ 30 ↔ 14 cm.
ART. 24199
↓ 40 ↔ 15 cm.



ART. 27158 P **T**
↓ 29 ↔ 16 cm.
ART. 27168 R/C
↓ 29 ↔ 16 cm.



ART. 27333 P **P**
↓ 21 ↔ 11,5 cm.
ART. 27341 R
↓ 21 ↔ 11,5 cm.



ART. 27174 P **T**
↓ 21 ↔ 11,5 cm.
ART. 27178 R
↓ 21 ↔ 11,5 cm.



ART. 27343 P **P**
↓ 14 ↔ 8 cm.
ART. 27342 R/C
↓ 14 ↔ 8 cm.



ART. 27179 P **T**
↓ 14 ↔ 9 cm.
ART. 27180 R/C
↓ 14 ↔ 9 cm.



ART. 27345 P **P**
↓ 11,5 ↔ 6 cm.



ART. 26151 Ø 6 **T**
↓ 27,5 ↔ 12 cm.



ART. 26309 Ø 5 **P**
↓ 19 ↔ 8,5 cm.
ART. 26178 Ø 5 **T**
↓ 19 ↔ 8,5 cm.



ART. 26343 Ø 4 **P**
↓ 15 ↔ 7 cm.
ART. 26179 Ø 4 **T**
↓ 15 ↔ 7 cm.



ART. 26345 Ø 4 **P**
↓ 13 ↔ 6 cm.



ART. 29478 P **P**
↓ 19,5 ↔ 16 cm.
ART. 29479 R/C
↓ 19,5 ↔ 16 cm.



ART. 29201 P **T**
↓ 19,5 ↔ 16 cm.
ART. 29202 R/C
↓ 19,5 ↔ 16 cm.



ART. 26968 **P**
↓ 19 ↔ 12 cm.
ART. 26868 **T**
↓ 19 ↔ 12 cm.
ART. 26869
↓ 21 ↔ 15 cm.



ART. 20153 7x9 cm.
ART. 20154 8x10 cm.
ART. 20263 9x12 cm.
ART. 20264 11x15 cm.
ART. 20265 13x18 cm.



ART. 20323 7x9 cm.
ART. 20324 8x10 cm.
ART. 20345 9x12 cm.
ART. 20346 10x15 cm.
ART. 20347 11x15 cm.
ART. 20348 13x18 cm.



ART. 20898 9x12 cm.
ART. 20899 11x15 cm.
ART. 20900 13x18 cm.



ART. 20901 9x12 cm.
ART. 20902 10x15 cm.
ART. 20909 11x15 cm.
ART. 20910 13x18 cm.



ART. 24195 ↓ 10 ↔ 6 cm.
ART. 24196 ↓ 15 ↔ 9 cm.
ART. 24197 ↓ 20 ↔ 11 cm.
ART. 24198 ↓ 30 ↔ 14 cm.
ART. 24199 ↓ 40 ↔ 15 cm.

Per ordinazioni aggiungere al codice articolo la lettera corrispondente alla colorazione scelta.

To place orders add to the article code the letter corresponding the selected colouring.

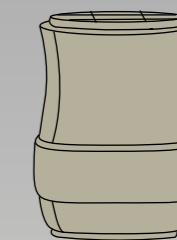
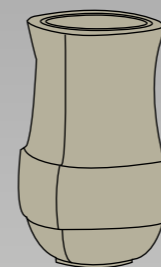

ART. 27333 P
↑ 21 ↔ 11,5 cm.

ART. 27158 P
↑ 29 ↔ 16 cm.

ART. 27341 R
↑ 21 ↔ 11,5 cm.

ART. 27168 R/C
↑ 29 ↔ 16 cm.

ART. 27343 P
↑ 14 ↔ 8 cm.

ART. 27174 P
↑ 21 ↔ 11,5 cm.

ART. 27342 R/C
↑ 14 ↔ 8 cm.

ART. 27178 R
↑ 21 ↔ 11,5 cm.

ART. 27345 P
↑ 11,5 ↔ 6 cm.

ART. 27179 P
↑ 14 ↔ 8 cm.

ART. 27180 R
↑ 14 ↔ 8 cm.

ART. 29478 P
↑ 19,5 ↔ 16 cm.

ART. 29201 P
↑ 19 ↔ 16 cm.

ART. 29479 R/C
↑ 19,5 ↔ 16 cm.

ART. 29202 R/C
↑ 19 ↔ 16 cm.

€ 386,20

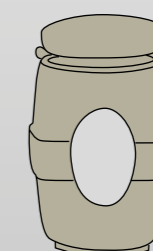

ART. 26309 Ø 5
↑ 19 ↔ 8,5 cm.

ART. 26151 Ø 6
↑ 27,5 ↔ 12 cm.

ART. 26343 Ø 4
↑ 15 ↔ 7 cm.

ART. 26178 Ø 5
↑ 19 ↔ 8,5 cm.

ART. 26345 Ø 4
↑ 13 ↔ 6 cm.

ART. 26179 Ø 4
↑ 15 ↔ 7 cm.

ART. 26968
↑ 19 ↔ 12 cm.

ART. 26868
↑ 19 ↔ 12 cm.

ART. 26869
↑ 21 ↔ 15 cm.

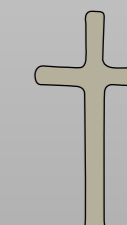
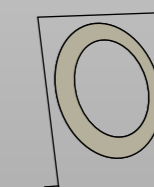
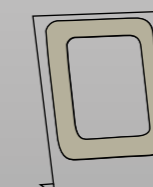
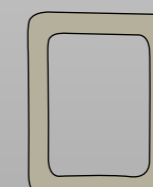

ART. 20153 7x9 cm.
ART. 20154 8x10 cm.
ART. 20263 9x12 cm.
ART. 20264 11x15 cm.
ART. 20265 13x18 cm.

ART. 20323 7x9 cm.
ART. 20324 8x10 cm.
ART. 20345 9x12 cm.
ART. 20346 10x15 cm.
ART. 20347 11x15 cm.
ART. 20348 13x18 cm.

ART. 20901 9x12 cm.
ART. 20902 10x15 cm.
ART. 20909 11x15 cm.
ART. 20910 13x18 cm.

ART. 20898 9x12 cm.
ART. 20899 11x15 cm.
ART. 20900 13x18 cm.

ART. 24195
↑ 10 ↔ 6 cm.
ART. 24196
↑ 15 ↔ 9 cm.
ART. 24197
↑ 20 ↔ 11 cm.
ART. 24198
↑ 30 ↔ 14 cm.
ART. 24199
↑ 40 ↔ 15 cm.

Per ordinazioni aggiungere al codice articolo la lettera corrispondente alla colorazione scelta.
To place orders add to the article code the letter corresponding the selected colouring.

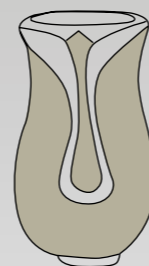

- ART. 27223 P ↓ 21 cm. ↔ 12 cm. **P**
- ART. 27222 I ↓ 21 cm. ↔ 12 cm. **P**
- ART. 27088 P ↓ 21 cm. ↔ 16 cm. **T**
- ART. 27087 I ↓ 21 cm. ↔ 16 cm. **T**
- ART. 27090 P ↓ 28 cm. ↔ 16 cm. **P**
- ART. 27089 I ↓ 28 cm. ↔ 16 cm. **P**

- ART. 27223 P ↓ 21 cm. ↔ 12 cm. **P**
- ART. 27222 I ↓ 21 cm. ↔ 12 cm. **P**
- ART. 27088 P ↓ 21 cm. ↔ 16 cm. **T**
- ART. 27087 I ↓ 21 cm. ↔ 16 cm. **T**
- ART. 27090 P ↓ 28 cm. ↔ 16 cm. **P**
- ART. 27089 I ↓ 28 cm. ↔ 16 cm. **P**

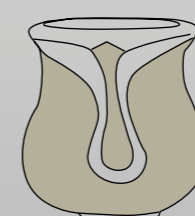
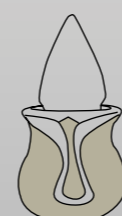

- ART. 29224 P ↓ 18 cm. ↔ 16 cm. **P**
- ART. 29028 P ↓ 18 cm. ↔ 16 cm. **T**
- ART. 29223 R/C ↓ 18 cm. ↔ 16 cm. **P**
- ART. 29026 R/C ↓ 18 cm. ↔ 16 cm. **T**

- ART. 26223 Ø 5 ↓ 20,5 cm. ↔ 12 cm. **P**
- ART. 26088 Ø 5 ↓ 20,5 cm. ↔ 12 cm. **T**

- ART. 26223 Ø 5 ↓ 20,5 cm. ↔ 12 cm. **P**
- ART. 26088 Ø 5 ↓ 20,5 cm. ↔ 12 cm. **T**

- ART. 29224 P ↓ 18 cm. ↔ 16 cm. **P**
- ART. 29028 P ↓ 18 cm. ↔ 16 cm. **T**
- ART. 29223 R/C ↓ 18 cm. ↔ 16 cm. **P**
- ART. 29026 R/C ↓ 18 cm. ↔ 16 cm. **T**

- ART. 26090 Ø 6 ↓ 26 cm. ↔ 12 cm. **P**

- ART. 26090 Ø 6 ↓ 26 cm. ↔ 12 cm. **P**

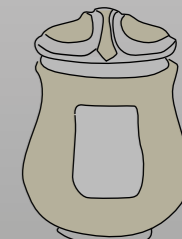
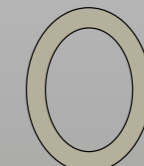
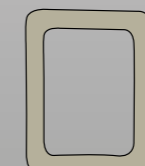
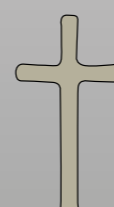

- ART. 26954 ↓ 17 ↔ 12 cm. **P**
- ART. 26854 ↓ 17 ↔ 12 cm. **T**
- ART. 26855 ↓ 23 ↔ 15 cm. **P**

- ART. 20323 7x9 cm.
- ART. 20324 8x10 cm.
- ART. 20345 9x12 cm.
- ART. 20346 10x15 cm.
- ART. 20347 11x15 cm.
- ART. 20348 13x18 cm.

- ART. 20153 7x9 cm.
- ART. 20154 8x10 cm.
- ART. 20263 9x12 cm.
- ART. 20264 11x15 cm.
- ART. 20265 13x18 cm.

- ART. 24195 ↓ 10 cm.
- ART. 24196 ↓ 15 cm.
- ART. 24197 ↓ 20 cm.
- ART. 24198 ↓ 30 cm.
- ART. 24199 ↓ 40 cm.

- ART. 24195 ↓ 10 ↔ 6 cm.
- ART. 24196 ↓ 15 ↔ 9 cm.
- ART. 24197 ↓ 20 ↔ 11 cm.
- ART. 24198 ↓ 30 ↔ 14 cm.
- ART. 24199 ↓ 40 ↔ 15 cm.

- ART. 20323 7x9 cm.
- ART. 20324 8x10 cm.
- ART. 20345 9x12 cm.
- ART. 20346 10x15 cm.
- ART. 20347 11x15 cm.
- ART. 20348 13x18 cm.

- ART. 20153 7x9 cm.
- ART. 20154 8x10 cm.
- ART. 20263 9x12 cm.
- ART. 20264 11x15 cm.
- ART. 20265 13x18 cm.

- ART. 26954 ↓ 17 ↔ 12 cm. **P**
- ART. 26854 ↓ 17 ↔ 12 cm. **T**
- ART. 26855 ↓ 23 ↔ 15 cm. **P**



ART. 21522 P T
↓ 29 ↔ 16 cm.



ART. 21260 P P
↓ 21 ↔ 13 cm.



ART. 21520 P T
↓ 21 ↔ 13 cm.



ART. 21258 P P
↓ 14 ↔ 8 cm.



ART. 21518 P T
↓ 14 ↔ 8 cm.



ART. 29363 P P
↓ 19 ↔ 17 cm.



ART. 29061 P T
↓ 19 ↔ 17 cm.

ART. 21523 R/C
↓ 29 ↔ 16 cm.

ART. 21261 R
↓ 21 ↔ 13 cm.

ART. 21521 R
↓ 21 ↔ 13 cm.

ART. 21259 R/C
↓ 14 ↔ 8 cm.

ART. 21519 R/C
↓ 14 ↔ 8 cm.

ART. 29362 R/C
↓ 19 ↔ 17 cm.

ART. 29062 R/C
↓ 19 ↔ 17 cm.



mezza vaschetta
ART. 29377 P
↓ 19 ↔ 20 cm.



mezza lampada
ART. 22377 Ø 5
↓ 21 ↔ 10 cm.



ART. 22845 T
↓ 22 ↔ 17 cm.



ART. 22938 P
↓ 17,5 ↔ 14 cm.

ART. 22838 T
↓ 17,5 ↔ 14 cm.



ART. 22521 Ø 6 T
↓ 28 ↔ 13 cm.



ART. 22269 Ø 5 P
↓ 20 ↔ 10 cm.



ART. 22258 Ø 4 P
↓ 14 ↔ 8 cm.

ART. 22520 Ø 5 T
↓ 20 ↔ 10 cm.

ART. 22518 Ø 4 T
↓ 14 ↔ 8 cm.



ART. 20153 7x9 cm.
ART. 20154 8x10 cm.
ART. 20263 9x12 cm.
ART. 20264 11x15 cm.
ART. 20265 13x18 cm.



ART. 20323 7x9 cm.
ART. 20324 8x10 cm.
ART. 20345 9x12 cm.
ART. 20346 10x15 cm.
ART. 20347 11x15 cm.
ART. 20348 13x18 cm.



ART. 20898 9x12 cm.
ART. 20899 11x15 cm.
ART. 20900 13x18 cm.



ART. 20901 9x12 cm.
ART. 20902 10x15 cm.
ART. 20909 11x15 cm.
ART. 20910 13x18 cm.



ART. 24195 ↓ 10 ↔ 6 cm.
ART. 24196 ↓ 15 ↔ 9 cm.
ART. 24197 ↓ 20 ↔ 11 cm.
ART. 24198 ↓ 30 ↔ 14 cm.
ART. 24199 ↓ 40 ↔ 15 cm.

Per ordinazioni aggiungere al codice articolo la lettera corrispondente alla colorazione scelta.

To place orders add to the article code the letter corresponding the selected colouring.

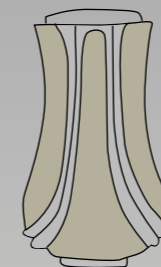

ART. 21258 P
↓ 14 ↔ 8 cm.

ART. 21259 R/C
↓ 14 ↔ 8 cm.

ART. 21260 P
↓ 21 ↔ 13 cm.

ART. 21261 R/C
↓ 21 ↔ 13 cm.

ART. 21518 P
↓ 14 ↔ 8 cm.

ART. 21519 R/C
↓ 14 ↔ 8 cm.

ART. 21520 P
↓ 21 ↔ 13 cm.

ART. 21521 R
↓ 21 ↔ 13 cm.

ART. 21522 P
↓ 29 ↔ 16 cm.

ART. 21523 R/C
↓ 29 ↔ 16 cm.

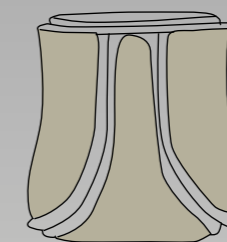

ART. 29363 P
↓ 19 ↔ 20 cm.

ART. 29362 R/C
↓ 19 ↔ 20 cm.

ART. 29061 P
↓ 19 ↔ 20 cm.

ART. 29062 R/C
↓ 19 ↔ 20 cm.

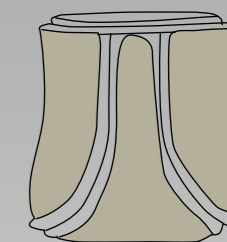

mezza vaschetta
ART. 29377 P
↓ 19 ↔ 20 cm.



ART. 22258 Ø 4
↓ 14 ↔ 18 cm.

ART. 22269 Ø 5
↓ 20 ↔ 10 cm.

ART. 22518 Ø 4
↓ 14 ↔ 18 cm.

ART. 22520 Ø 5
↓ 20 ↔ 10 cm.

ART. 22521 Ø 6
↓ 28 ↔ 13 cm.

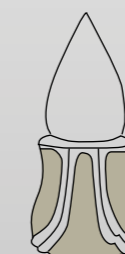

mezza lampada
ART. 22377 Ø 5
↓ 21 ↔ 10 cm.



ART. 22938 P
4 gg. ↓ 17,5 ↔ 14 cm.

ART. 22838 4 gg.
↓ 17,5 ↔ 14 cm.

ART. 22845 6 gg.
↓ 22 ↔ 17 cm.



ART. 20153 7x9 cm.
ART. 20154 8x10 cm.
ART. 20263 9x12 cm.
ART. 20264 11x15 cm.
ART. 20265 13x18 cm.

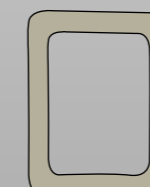

ART. 20323 7x9 cm.
ART. 20324 8x10 cm.
ART. 20345 9x12 cm.
ART. 20346 10x15 cm.
ART. 20347 11x15 cm.
ART. 20348 13x18 cm.

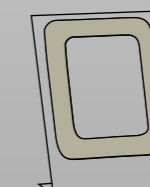

ART. 20901 9x12 cm.
ART. 20902 10x15 cm.
ART. 20909 11x15 cm.
ART. 20910 13x18 cm.

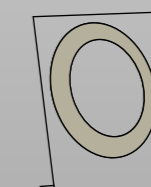

ART. 20898 9x12 cm.
ART. 20899 11x15 cm.
ART. 20900 13x18 cm.

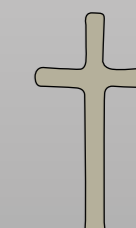

ART. 24195 ↓ 10 ↔ 6 cm.
ART. 24196 ↓ 15 ↔ 9 cm.
ART. 24197 ↓ 20 ↔ 11 cm.
ART. 24198 ↓ 30 ↔ 14 cm.
ART. 24199 ↓ 40 ↔ 15 cm.



ART. 27129 P T
↓ 28 ↔ 17 cm.

ART. 27128 I
↓ 28 ↔ 17 cm.



ART. 27435 P P
↓ 20 ↔ 12 cm.

ART. 27434 I
↓ 20 ↔ 12 cm.



ART. 27135 P T
↓ 20 ↔ 12 cm.

ART. 27134 I
↓ 20 ↔ 12 cm.



ART. 29448 P P
↓ 19 ↔ 16 cm.

ART. 29447 R/C
↓ 19 ↔ 16 cm.



ART. 29135 P T
↓ 19 ↔ 16 cm.

ART. 29134 R/C
↓ 19 ↔ 16 cm.



ART. 27437 P P
↓ 12 ↔ 7,5 cm.

ART. 27436 R/C
↓ 12 ↔ 7,5 cm.



ART. 27438 P P
↓ 11 ↔ 6,5 cm.

ART. 27138 P T
↓ 12 ↔ 7,5 cm.

ART. 27137 R/C
↓ 12 ↔ 7,5 cm.



ART. 26128 Ø 6 T
↓ 27 ↔ 12 cm.



ART. 26434 Ø 5 P
↓ 21 ↔ 10 cm.

ART. 26134 Ø 5 T
↓ 21 ↔ 10 cm.



ART. 26436 Ø 4 P
↓ 13 ↔ 7 cm.

ART. 26137 Ø 4 T
↓ 13 ↔ 7 cm.



ART. 26917 P
↓ 17 ↔ 11 cm.

ART. 26817 T
↓ 17 ↔ 11 cm.

ART. 26818
↓ 23 ↔ 15 cm.



ART. 20153 7x9 cm.
ART. 20154 8x10 cm.
ART. 20263 9x12 cm.
ART. 20264 11x15 cm.
ART. 20265 13x18 cm.



ART. 20323 7x9 cm.
ART. 20324 8x10 cm.
ART. 20345 9x12 cm.
ART. 20346 10x15 cm.
ART. 20347 11x15 cm.
ART. 20348 13x18 cm.



ART. 24195 ↓ 10 ↔ 6 cm.
ART. 24196 ↓ 15 ↔ 9 cm.
ART. 24197 ↓ 20 ↔ 11 cm.
ART. 24198 ↓ 30 ↔ 14 cm.
ART. 24199 ↓ 40 ↔ 15 cm.

Per ordinazioni aggiungere al codice articolo la lettera corrispondente alla colorazione scelta.
To place orders add to the article code the letter corresponding the selected colouring.

Per ordinazioni aggiungere al codice articolo la lettera corrispondente alla colorazione scelta.
To place orders add to the article code the letter corresponding the selected colouring.

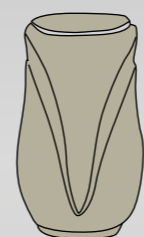
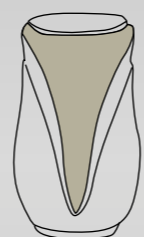

- ART. 27435 P ↓ 20 ↔ 12 cm.
- ART. 27434 I ↓ 20 ↔ 12 cm.
- ART. 27437 P ↓ 12 ↔ 7,5 cm.
- ART. 27436 R/C ↓ 12 ↔ 7,5 cm.

- ART. 27129 P ↓ 28 ↔ 17 cm.
- ART. 27128 I ↓ 28 ↔ 17 cm.
- ART. 27135 P ↓ 20 ↔ 12 cm.
- ART. 27134 I ↓ 20 ↔ 12 cm.
- ART. 27138 P ↓ 12 ↔ 7,5 cm.
- ART. 27137 R/C ↓ 12 ↔ 7,5 cm.

- ART. 27654 P ↓ 20 ↔ 12 cm.
- ART. 27653 I ↓ 20 ↔ 12 cm.
- ART. 27656 P ↓ 12 ↔ 7,5 cm.
- ART. 27655 R/C ↓ 12 ↔ 7,5 cm.

- ART. 27810 P ↓ 28 ↔ 17 cm.
- ART. 27809 I ↓ 28 ↔ 17 cm.
- ART. 27812 P ↓ 20 ↔ 12 cm.
- ART. 27811 I ↓ 20 ↔ 12 cm.
- ART. 27814 P ↓ 12 ↔ 7,5 cm.
- ART. 27813 R/C ↓ 12 ↔ 7,5 cm.

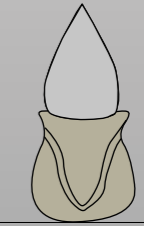
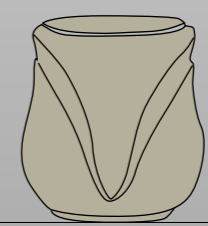
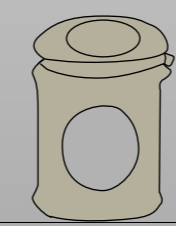
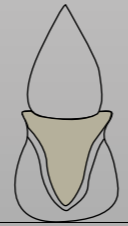
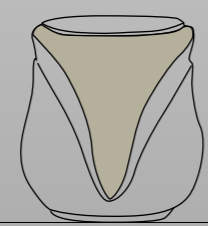
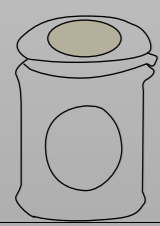

- ART. 26917 4 gg. ↓ 17 ↔ 11 cm.
- ART. 26817 4 gg. ↓ 17 ↔ 11 cm.
- ART. 26818 6 gg. ↓ 23 ↔ 15 cm.

- ART. 29448 P ↓ 19 ↔ 16 cm.
- ART. 29447 R/C ↓ 19 ↔ 16 cm.
- ART. 29135 P ↓ 19 ↔ 16 cm.
- ART. 29134 R/C ↓ 19 ↔ 16 cm.

- ART. 26434 Ø 5 ↓ 21 ↔ 10 cm.
- ART. 26436 Ø 4 ↓ 13 ↔ 7 cm.
- ART. 26128 Ø 6 ↓ 27 ↔ 12 cm.
- ART. 26134 Ø 5 ↓ 21 ↔ 10 cm.
- ART. 26137 Ø 4 ↓ 13 ↔ 7 cm.

- ART. 26982 4 gg. ↓ 17 ↔ 11 cm.
- ART. 26882 4 gg. ↓ 17 ↔ 11 cm.
- ART. 26883 6 gg. ↓ 23 ↔ 15 cm.

- ART. 29500 P ↓ 19 ↔ 16 cm.
- ART. 29400 R/C ↓ 19 ↔ 16 cm.
- ART. 29278 P ↓ 19 ↔ 16 cm.
- ART. 29001 R/C ↓ 19 ↔ 16 cm.

- ART. 26453 Ø 5 ↓ 21 ↔ 10 cm.
- ART. 26455 Ø 4 ↓ 13 ↔ 7 cm.
- ART. 26226 Ø 6 ↓ 27 ↔ 12 cm.
- ART. 26225 Ø 5 ↓ 21 ↔ 10 cm.
- ART. 26224 Ø 4 ↓ 13 ↔ 7 cm.



ART. 27046 R **T**
↓ 28 ↔ 18 cm.



ART. 27347 R **P**
↓ 20 ↔ 13,5 cm.



ART. 29560 R/C **P**
↓ 18 ↔ 18 cm.

ART. 27047 R **T**
↓ 20 ↔ 13,5 cm.

ART. 29060 R/C **T**
↓ 18 ↔ 18 cm.



ART. 26046 Ø 6 **T**
↓ 27 ↔ 12 cm.



ART. 26347 Ø 5 **P**
↓ 20 ↔ 9 cm.



mezza lampada **P**
ART. 22426 Ø 5
↓ 20 ↔ 9 cm.

ART. 26047 Ø 5 **T**
↓ 20 ↔ 9 cm.



mezza vaschetta **P**
ART. 29333 P
↓ 16 ↔ 30 cm.



mezza vaschetta **P**
ART. 29426 P
↓ 18 ↔ 18 cm.



ART. 26917 **P** ART. 26817 **T**
↓ 17 ↔ 11 cm. ↓ 17 ↔ 11 cm.
ART. 26818
↓ 23 ↔ 15 cm.



ART. 20153 7x9 cm.
ART. 20154 8x10 cm.
ART. 20263 9x12 cm.
ART. 20264 11x15 cm.
ART. 20265 13x18 cm.



ART. 20323 7x9 cm.
ART. 20324 8x10 cm.
ART. 20345 9x12 cm.
ART. 20346 10x15 cm.
ART. 20347 11x15 cm.
ART. 20348 13x18 cm.



ART. 20898 9x12 cm.
ART. 20899 11x15 cm.
ART. 20900 13x18 cm.



ART. 20901 9x12 cm.
ART. 20902 10x15 cm.
ART. 20909 11x15 cm.
ART. 20910 13x18 cm.



ART. 24195 ↓ 10 ↔ 6 cm.
ART. 24196 ↓ 15 ↔ 9 cm.
ART. 24197 ↓ 20 ↔ 11 cm.
ART. 24198 ↓ 30 ↔ 14 cm.
ART. 24199 ↓ 40 ↔ 15 cm.



Per ordinazioni aggiungere al codice articolo la lettera corrispondente alla colorazione scelta.
To place orders add to the article code the letter corresponding the selected colouring.

Per ordinazioni aggiungere al codice articolo la lettera corrispondente alla colorazione scelta.
To place orders add to the article code the letter corresponding the selected colouring.

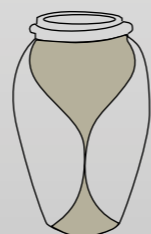

ART. 27347 R **P** ART. 27046 R **T**
↓ 20 ↔ 13,5 cm. ↓ 28 ↔ 13,5 cm.
ART. 27047 R
↓ 20 ↔ 18 cm.



ART. 27657 R **P** ART. 27815 R **T**
↓ 20 ↔ 13,5 cm. ↓ 28 ↔ 13,5 cm.
ART. 27816 R
↓ 20 ↔ 13,5 cm.

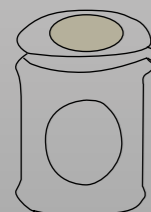

ART. 26917 4 gg. **P** ART. 26817 6 gg. **T**
↓ 17 ↔ 11 cm. ↓ 17 ↔ 11 cm.
ART. 26818 6 gg.
↓ 23 ↔ 15 cm.

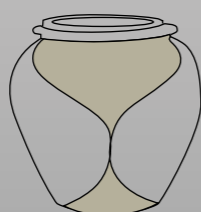

ART. 29426 P mezza **P** ART. 29060 R/C **T**
↓ 18 ↔ 18 cm. ↓ 18 ↔ 18 cm.
ART. 29560 R/C
↓ 18 ↔ 18 cm.

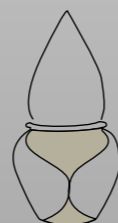

ART. 22426 mezza **P** ART. 26046 Ø 6 **T**
Ø 5 ↓ 20 ↔ 9 cm. ↓ 27 ↔ 12 cm.
ART. 26347 Ø 5 ART. 26047 Ø 5
↓ 20 ↔ 9 cm. ↓ 20 ↔ 9 cm.

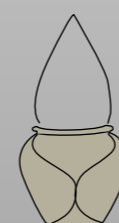

ART. 26633 mezza **P** ART. 26231 Ø 6 **T**
Ø 5 ↓ 20 ↔ 9 cm. ↓ 27 ↔ 12 cm.
ART. 26632 Ø 5 ART. 26232 Ø 5
↓ 20 ↔ 9 cm. ↓ 20 ↔ 9 cm.

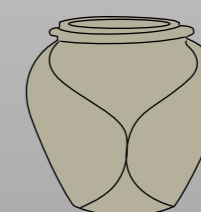

ART. 29712 P mezza **P** ART. 29649 R/C **T**
↓ 18 ↔ 18 cm. ↓ 18 ↔ 18 cm.
ART. 29713 R/C
↓ 18 ↔ 18 cm.

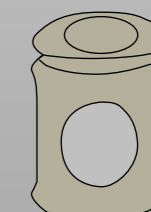

ART. 26982 4 gg. **P** ART. 26882 4 gg. **T**
↓ 17 ↔ 11 cm. ↓ 17 ↔ 11 cm.
ART. 26883 6 gg.
↓ 23 ↔ 15 cm.



ART. 27050 R **T**
↑ 28 ↔ 18 cm.



ART. 27351 R **P** ART. 27051 R **T**
↑ 20 ↔ 13,5 cm. ↑ 20 ↔ 13,5 cm.



ART. 29563 R/C **P**
↑ 18 ↔ 18 cm.

ART. 29063 R/C **T**
↑ 18 ↔ 18 cm.



ART. 26050 Ø 6 **T**
↑ 27 ↔ 12 cm.



ART. 26351 Ø 5 **P**
↑ 20 ↔ 9 cm.

ART. 26051 Ø 5 **T**
↑ 20 ↔ 9 cm.



ART. 26919 **P** ART. 26819 **T**
↑ 17 ↔ 11 cm. ↑ 17 ↔ 11 cm.

ART. 26820
↑ 23 ↔ 15 cm.

ART. 26821
↑ 30,5 ↔ 14 cm.



mezza lampada **P**
ART. 22443
↑ 20 ↔ 9 cm.



mezza vaschetta **P**
ART. 29443 P
↑ 18 ↔ 18 cm.



ART. 20423 7x9 cm.
ART. 20424 8x10 cm.
ART. 20425 9x12 cm.
ART. 20426 11x15 cm.
ART. 20427 13x18 cm.



ART. 20433 7x9 cm.
ART. 20434 8x10 cm.
ART. 20435 9x12 cm.
ART. 20436 10x15 cm.
ART. 20437 11x15 cm.
ART. 20438 13x18 cm.



ART. 20516 9x12 cm.
ART. 20517 11x15 cm.
ART. 20518 13x18 cm.



ART. 20603 9x12 cm.
ART. 20604 10x15 cm.
ART. 20605 11x15 cm.
ART. 20606 13x18 cm.



ART. 24290 ↑ 10 ↔ 6 cm.
ART. 24291 ↑ 15 ↔ 9 cm.
ART. 24292 ↑ 20 ↔ 11 cm.
ART. 24293 ↑ 30 ↔ 14 cm.
ART. 24294 ↑ 40 ↔ 15 cm.



ART. 21422 P
↓ 28 ↔ 16,5 cm.

ART. 21423 I
↓ 28 ↔ 16,5 cm.



ART. 21242 P
↓ 20 ↔ 13,5 cm.

ART. 21241 I
↓ 20 ↔ 13,5 cm.



ART. 21418 P
↓ 20 ↔ 13,5 cm.

ART. 21419 I
↓ 20 ↔ 13,5 cm.



ART. 21243 P
↓ 15 ↔ 9 cm.

ART. 21246 R
↓ 15 ↔ 9 cm.



ART. 21417 P
↓ 15 ↔ 9 cm.

ART. 21414 R
↓ 15 ↔ 9 cm.

ART. 29207 P
↓ 19 ↔ 18 cm.

ART. 29206 R/C
↓ 19 ↔ 18 cm.

ART. 29423 P
↓ 19 ↔ 18 cm.

ART. 29422 R/C
↓ 19 ↔ 18 cm.

ART. 21462 P
↓ 12 ↔ 5,5 cm.



ART. 22421 Ø 6
↓ 26 ↔ 13 cm.



ART. 22242 Ø 5
↓ 20 ↔ 10 cm.

ART. 22419 Ø 5
↓ 20 ↔ 10 cm.



ART. 22243 Ø 4
↓ 14 ↔ 8 cm.

ART. 22418 Ø 4
↓ 14 ↔ 8 cm.



ART. 22951
↓ 17 ↔ 11 cm.

ART. 22852
↓ 17 ↔ 11 cm.

ART. 22853
↓ 23 ↔ 15 cm.



mezza vaschetta
ART. 29311 P
↓ 17 ↔ 28 cm.



ART. 29525
↓ 22 ↔ 30 cm.



ART. 21449 I
↓ 10 ↔ 17 cm.



ART. 22446 Ø 5
↓ 16 ↔ 10 cm.



mezza vaschetta
ART. 29309 P
↓ 17 ↔ 19 cm.

ART. 29295 R/C
↓ 17 ↔ 19 cm.

mezza vaschetta
ART. 29315 P
↓ 17 ↔ 19 cm.

ART. 29296 R/C
↓ 17 ↔ 19 cm.



mezza lampada
ART. 22285 Ø 5
↓ 20 ↔ 10 cm.

ART. 22286 Ø 5
↓ 20 ↔ 10 cm.



ART. 21249 P
↓ 13 ↔ 7,5 cm.



ART. 22249 Ø 4
↓ 12 ↔ 7,5 cm.

Per ordinazioni aggiungere al codice articolo la lettera corrispondente alla colorazione scelta.

To place orders add to the article code the letter corresponding the selected colouring.

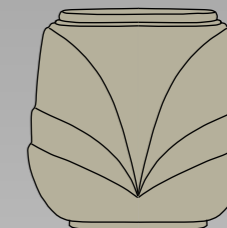
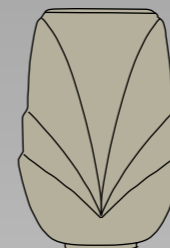

ART. 21242 P ↓ 20 ↔ 13,5 cm. **P**

ART. 21422 P ↓ 28 ↔ 16,5 cm. **T**

ART. 29207 P ↓ 19 ↔ 18 cm. **P**

ART. 21241 I ↓ 20 ↔ 13,5 cm.

ART. 21423 I ↓ 28 ↔ 16,5 cm.

ART. 29206 R/C ↓ 19 ↔ 18 cm. **P**

ART. 21243 P ↓ 15 ↔ 9 cm.

ART. 21418 P ↓ 20 ↔ 13,5 cm.

ART. 29423 P ↓ 19 ↔ 18 cm. **T**

ART. 21246 R ↓ 15 ↔ 9 cm.

ART. 21419 I ↓ 20 ↔ 13,5 cm.

ART. 29422 R/C ↓ 19 ↔ 18 cm. **T**

ART. 21417 P ↓ 15 ↔ 9 cm.

ART. 21414 R ↓ 15 ↔ 9 cm.

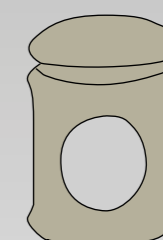
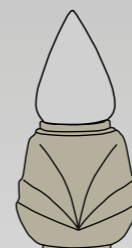

ART. 22242 Ø 5 ↓ 20 ↔ 10 cm. **P**

ART. 22419 Ø 5 ↓ 20 ↔ 10 cm. **T**

ART. 22951 ↓ 17 ↔ 11 cm. **P**

ART. 22243 Ø 4 ↓ 14 ↔ 8 cm.

ART. 22418 Ø 4 ↓ 14 ↔ 8 cm.

ART. 22852 ↓ 17 ↔ 11 cm. **T**

ART. 22421 Ø 6 ↓ 26 ↔ 13 cm.

ART. 22853 ↓ 23 ↔ 15 cm. **T**

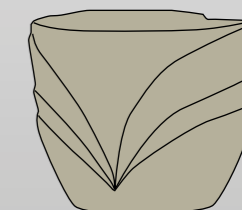
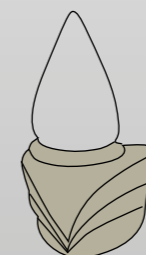
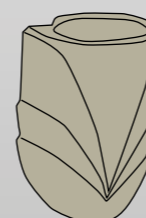

ART. 21249 P ↓ 13 ↔ 7,5 cm. **P**

mezza lampada
ART. 22249 Ø 4 ↓ 12 ↔ 7,5 cm. **P**

mezza vaschetta **P**
ART. 29309 P ↓ 17 ↔ 19 cm.

ART. 22285 Ø 5 ↓ 20 ↔ 10 cm.

ART. 22286 Ø 5 ↓ 20 ↔ 10 cm. **T**

ART. 29295 R/C ↓ 17 ↔ 19 cm. **P**

ART. 29315 P ↓ 17 ↔ 19 cm. **T**

ART. 29296 R/C ↓ 17 ↔ 19 cm. **T**

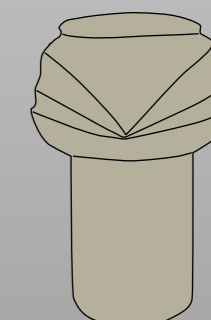
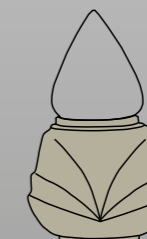
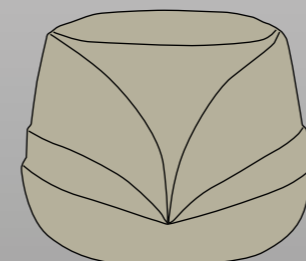

ART. 29525 ↓ 22 ↔ 30 cm. **T**

incasso
ART. 22446 Ø 5 ↓ 16 ↔ 10 cm.

ART. 21449 I ↓ 10 ↔ 17 cm. **T**



ART. 21363SD R/C P
↓ 24 ↔ 13 cm.

ART. 21163SD R/C T
↓ 24 ↔ 13 cm.

ART. 21161SD R
↓ 28 ↔ 16 cm.

ART. 21162SD I
↓ 32 ↔ 18 cm.

ART. 21095SD R
↓ 40 ↔ 20 cm.

ART. 21096SD R
↓ 50 ↔ 25 cm.

ART. 21099SD R
↓ 60 ↔ 29 cm.



ART. 21360SD R P
↓ 20 ↔ 11 cm.

ART. 21368SD P
↓ 18 ↔ 10 cm.

ART. 21367SD R/C
↓ 18 ↔ 10 cm.

ART. 21359SD R/C
↓ 15 ↔ 10 cm.

ART. 21371SD P
↓ 11 ↔ 6 cm.



ART. 21160SD R T
↓ 20 ↔ 11 cm.

ART. 21168SD P
↓ 18 ↔ 10 cm.

ART. 21167SD R/C
↓ 18 ↔ 10 cm.

ART. 21159SD R/C
↓ 15 ↔ 10 cm.



ART. 29298SD R/C P
↓ 17 ↔ 15 cm.

ART. 29098SD R/C T
↓ 17 ↔ 15 cm.

ART. 29014SD R T
↓ 16 ↔ 22 cm.

ART. 29005SD R
↓ 17 ↔ 31 cm.



ART. 21310 P P
↓ 18 ↔ 10 cm.

ART. 21311 R/C
↓ 18 ↔ 10 cm.

ART. 21307 R
↓ 20 ↔ 11 cm.

ART. 21306 R/C
↓ 24 ↔ 13 cm.



ART. 22310 Ø5 P
↓ 19 ↔ 9 cm.



ART. 29242 R/C P
↓ 17 ↔ 15 cm.



ART. 26243 Ø5 P
↓ 20 ↔ 10 cm.

ART. 26042 Ø5 T
↓ 20 ↔ 10 cm.



ART. 27247 P P
↓ 18,5 ↔ 14 cm.

ART. 27042 P T
↓ 18,5 ↔ 14 cm.



ART. 22161SD Ø 6 T
↓ 27 ↔ 13 cm.



ART. 22360SD Ø 5 P
↓ 19 ↔ 9 cm.

ART. 22160SD Ø 5 T
↓ 19 ↔ 9 cm.

ART. 22359SD Ø 4
↓ 14 ↔ 8 cm.

ART. 22159SD Ø 4
↓ 14 ↔ 8 cm.



ART. 22951 P
↓ 17 ↔ 11 cm.

ART. 22852 T
↓ 17 ↔ 11 cm.



ART. 22935 P
↓ 17 ↔ 11 cm.

ART. 22853
↓ 23 ↔ 15 cm.

Per ordinazioni aggiungere al codice articolo la lettera corrispondente alla colorazione scelta.

To place orders add to the article code the letter corresponding the selected colouring.

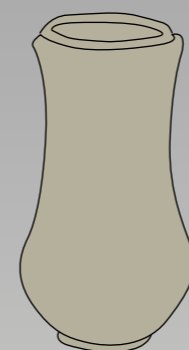

ART. 21363 R/C **P**
↓ 24 ↔ 13 cm.

ART. 21163 R/C **T**
↓ 24 ↔ 13 cm.

ART. 21161 R
↓ 28 ↔ 16 cm.

ART. 21162 I
↓ 32 ↔ 18 cm.

ART. 21095 R
↓ 40 ↔ 20 cm.

ART. 21096 R
↓ 50 ↔ 25 cm.

ART. 21099 R
↓ 60 ↔ 29 cm.



ART. 21360 R **P**
↓ 20 ↔ 11 cm.

ART. 21368 P
↓ 18 ↔ 10 cm.

ART. 21367 R/C
↓ 18 ↔ 10 cm.

ART. 21359 R/C
↓ 15 ↔ 10 cm.

ART. 21371 P
↓ 11 ↔ 6 cm.

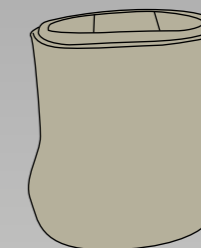

ART. 21160 R **T**
↓ 20 ↔ 11 cm.

ART. 21168 P
↓ 18 ↔ 10 cm.

ART. 21167 R/C
↓ 18 ↔ 10 cm.

ART. 21159 R/C
↓ 15 ↔ 10 cm.

ART. 29298 R/C **P**
↓ 17 ↔ 15 cm.

ART. 29098 R/C **T**
↓ 17 ↔ 15 cm.



ART. 29014 R **T**
↓ 16 ↔ 22 cm.

ART. 29005 R
↓ 17 ↔ 31 cm.

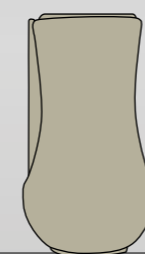

ART. 21310 P **P**
↓ 18 ↔ 10 cm.

ART. 21311 R/C
↓ 18 ↔ 10 cm.

ART. 21307 R
↓ 20 ↔ 11 cm.

ART. 21306 R/C
↓ 24 ↔ 13 cm.

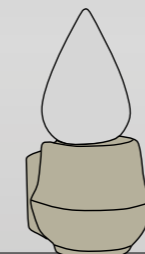

ART. 22310 Ø 5 **P**
↓ 19 ↔ 9 cm.

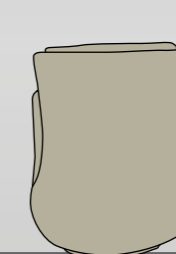

ART. 29242 R/C **P**
↓ 17 ↔ 15 cm.

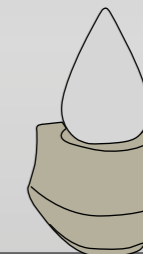

ART. 26243 Ø 5 **P**
↓ 20 ↔ 10 cm.

ART. 26042 Ø 5 **T**
↓ 20 ↔ 10 cm.



ART. 27247 P **P**
↓ 18,5 ↔ 14 cm.

ART. 27042 P **T**
↓ 18,5 ↔ 14 cm.

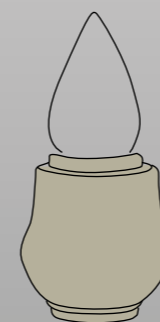

ART. 22161 Ø 6 **T**
↓ 27 ↔ 13 cm.

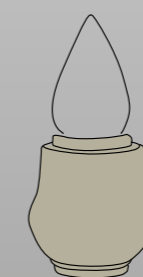

ART. 22360 Ø 5 **P**
↓ 19 ↔ 9 cm.

ART. 22359 Ø 4
↓ 14 ↔ 8 cm.

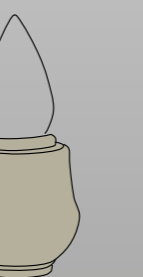

ART. 22160 Ø 5 **T**
↓ 19 ↔ 9 cm.

ART. 22159 Ø 4
↓ 14 ↔ 8 cm.

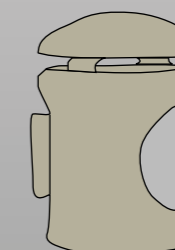

ART. 22935 **P**
↓ 17 ↔ 11 cm.

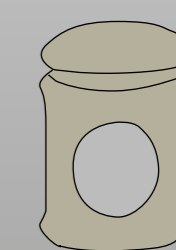

ART. 22951 **P**
↓ 17 ↔ 11 cm.

ART. 22852 **T**
↓ 17 ↔ 11 cm.

ART. 22853
↓ 23 ↔ 15 cm.



ART. 21363 R/C P
↓ 24 ↔ 13 cm.

ART. 21163 R/C T
↓ 24 ↔ 13 cm.

ART. 21161 R
↓ 28 ↔ 16 cm.

ART. 21162 I
↓ 32 ↔ 18 cm.

ART. 21095 R
↓ 40 ↔ 20 cm.

ART. 21096 R
↓ 50 ↔ 25 cm.

ART. 21099 R
↓ 60 ↔ 29 cm.



ART. 21360 R P
↓ 20 ↔ 11 cm.

ART. 21368 P
↓ 18 ↔ 10 cm.

ART. 21367 R/C
↓ 18 ↔ 10 cm.

ART. 21359 R/C
↓ 15 ↔ 10 cm.

ART. 21371 P
↓ 11 ↔ 6 cm.



ART. 21160 R T
↓ 20 ↔ 11 cm.

ART. 21168 P
↓ 18 ↔ 10 cm.

ART. 21167 R/C
↓ 18 ↔ 10 cm.

ART. 21159 R/C
↓ 15 ↔ 10 cm.



ART. 29298 R/C P
↓ 17 ↔ 15 cm.

ART. 29098 R/C T
↓ 17 ↔ 15 cm.

ART. 29014 R T
↓ 16 ↔ 22 cm.

ART. 29005 R
↓ 17 ↔ 31 cm.



ART. 22161 Ø 6 T
↓ 27 ↔ 13 cm.



ART. 22360 Ø 5 P
↓ 19 ↔ 9 cm.



ART. 22160 Ø 5 T
↓ 19 ↔ 9 cm.



ART. 22840 P
↓ 17 ↔ 11 cm.



ART. 22841 T
↓ 17 ↔ 11 cm.

ART. 22842
↓ 23 ↔ 15 cm.

ART. 26248 Ø 5 P
↓ 20 ↔ 10 cm.

ART. 26043 Ø 5 T
↓ 20 ↔ 10 cm.

ART. 27248 P
↓ 18,5 ↔ 14 cm.

ART. 27043 P
↓ 18,5 ↔ 14 cm.



ART. 20458 7x9 cm.
ART. 20459 8x10 cm.
ART. 20455 9x12 cm.
ART. 20456 11x15 cm.
ART. 20457 13x18 cm.



ART. 20465 9x12 cm.
ART. 20466 10x15 cm.
ART. 20467 11x15 cm.
ART. 20468 13x18 cm.



ART. 20050 9x12 cm.
ART. 20051 11x15 cm.
ART. 20052 13x18 cm.



ART. 20053 9x12 cm.
ART. 20054 10x15 cm.
ART. 20055 11x15 cm.
ART. 20056 13x18 cm.



ART. 24030 10x6 cm.
ART. 24031 15x9 cm.
ART. 24032 20x11 cm.
ART. 24033 30x14 cm.
ART. 24049 40x15 cm.



ART. 21289 R/C P
↓ 24 ↔ 13 cm.

ART. 21089 R/C T
↓ 24 ↔ 16 cm.

ART. 21074 R
↓ 28 ↔ 16 cm.

ART. 21073 I
↓ 32 ↔ 18 cm.



ART. 21203 R P
↓ 20 ↔ 11 cm.

ART. 21389 P
↓ 18 ↔ 10 cm.

ART. 21304 R/C
↓ 18 ↔ 10 cm.

ART. 21287 R/C
↓ 15 ↔ 10 cm.



ART. 21103 R T
↓ 20 ↔ 11 cm.

ART. 21189 P
↓ 18 ↔ 10 cm.

ART. 21104 R/C
↓ 18 ↔ 10 cm.

ART. 21187 R/C
↓ 15 ↔ 10 cm.



ART. 29366 R/C P
↓ 17 ↔ 15 cm.

ART. 29266 R/C T
↓ 17 ↔ 15 cm.

ART. 29268 R T
↓ 16 ↔ 22 cm.

ART. 29269 R T
↓ 17 ↔ 31 cm.



ART. 22074 Ø 6 T
↓ 27 ↔ 13 cm.



ART. 22206 Ø 5 P
↓ 19 ↔ 9 cm.

ART. 22287 Ø 4
↓ 14 ↔ 8 cm.

ART. 22103 Ø 5 T
↓ 19 ↔ 9 cm.

ART. 22183 Ø 4
↓ 14 ↔ 8 cm.



ART. 22933 P
↓ 17 ↔ 11 cm.

ART. 22833 T
↓ 17 ↔ 11 cm.

ART. 22834
↓ 23 ↔ 15 cm.



ART. 26249 Ø 5 P
↓ 20 ↔ 10 cm.

ART. 26044 Ø 5 T
↓ 20 ↔ 10 cm.



ART. 27249 P P
↓ 18,5 ↔ 14 cm.

ART. 27044 P T
↓ 18,5 ↔ 14 cm.



ART. 20806 7x9 cm.
ART. 20807 8x10 cm.
ART. 20808 9x12 cm.
ART. 20809 11x15 cm.
ART. 20810 13x18 cm.



ART. 20816 9x12 cm.
ART. 20817 10x15 cm.
ART. 20818 11x15 cm.
ART. 20819 13x18 cm.



ART. 20583 9x12 cm.
ART. 20584 11x15 cm.
ART. 20585 13x18 cm.



ART. 20565 9x12 cm.
ART. 20566 10x15 cm.
ART. 20567 11x15 cm.
ART. 20568 13x18 cm.



ART. 24230 10x6 cm.
ART. 24231 15x9 cm.
ART. 24232 20x11 cm.
ART. 24233 30x14 cm.
ART. 24234 40x15 cm.

Per ordinazioni aggiungere al codice articolo la lettera corrispondente alla colorazione scelta.
To place orders add to the article code the letter corresponding the selected colouring.



ART. 21509 P **P** ↓ 20 ↔ 12 cm.
ART. 21504 R/C ↓ 20 ↔ 12 cm.
ART. 21409 P **T** ↓ 20 ↔ 12 cm.
ART. 21404 R/C ↓ 20 ↔ 12 cm.
ART. 21424 R/C ↓ 28 ↔ 17 cm.

ART. 21509 P **P** ↓ 20 ↔ 12 cm.
ART. 21504 R/C ↓ 20 ↔ 12 cm.
ART. 21409 P **T** ↓ 20 ↔ 12 cm.
ART. 21404 R/C ↓ 20 ↔ 12 cm.
ART. 21424 R/C ↓ 28 ↔ 17 cm.

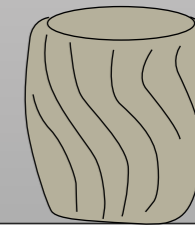
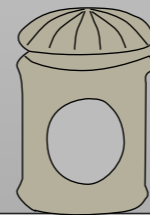

ART. 29501 P **P** ↓ 17 ↔ 16 cm.
ART. 29503 R/C ↓ 17 ↔ 16 cm.
ART. 29401 P **T** ↓ 17 ↔ 16 cm.
ART. 29404 R/C ↓ 17 ↔ 16 cm.

ART. 22504 Ø 5 **P** ↓ 20 ↔ 10 cm.
ART. 22404 Ø 5 **T** ↓ 20 ↔ 10 cm.
ART. 22424 Ø 6 ↓ 24 ↔ 13 cm.

ART. 22975 **P** ↓ 17,5 ↔ 11 cm.
ART. 22875 **T** ↓ 17,5 ↔ 11 cm.
ART. 22876 ↓ 21 ↔ 14 cm.
ART. 22877 ↓ 30,5 ↔ 14 cm.

ART. 22975 **P** ↓ 17,5 ↔ 11 cm.
ART. 22877 **T** ↓ 17,5 ↔ 11 cm.
ART. 22876 ↓ 21 ↔ 14 cm.
ART. 22875 ↓ 30,5 ↔ 14 cm.

ART. 22504 Ø 5 **P** ↓ 20 ↔ 10 cm.
ART. 22404 Ø 5 **T** ↓ 20 ↔ 10 cm.
ART. 22424 Ø 6 ↓ 24 ↔ 13 cm.

ART. 29501 P **P** ↓ 17 ↔ 16 cm.
ART. 29503 R/C ↓ 17 ↔ 16 cm.
ART. 29401 P **T** ↓ 17 ↔ 16 cm.
ART. 29404 R/C ↓ 17 ↔ 16 cm.



ART. 21071SD R/C **T**
↓ 28 ↔ 15 cm.



ART. 21272SD P **P** ART. 21072SD P **T**
↓ 20 ↔ 11 cm. ↓ 20 ↔ 11 cm.

ART. 21270SD R/C ART. 21070SD R/C
↓ 20 ↔ 11 cm. ↓ 20 ↔ 11 cm.



ART. 21264SD P **P** ART. 21064SD P **T**
↓ 17 ↔ 9 cm. ↓ 17 ↔ 9 cm.

ART. 21269SD R/C ART. 21069SD R/C
↓ 17 ↔ 9 cm. ↓ 17 ↔ 9 cm.

ART. 21233SD P ART. 21067SD P
↓ 11 ↔ 7 cm. ↓ 11 ↔ 7 cm.

ART. 21268SD R ART. 21068SD R
↓ 13 ↔ 7 cm. ↓ 13 ↔ 7 cm.



ART. 22071SD Ø 6 **T**
↓ 24 ↔ 13 cm.



ART. 22270SD Ø 5 **P**
↓ 19 ↔ 8 cm.

ART. 22070SD Ø 5 **T**
↓ 19 ↔ 8 cm.



ART. 22268SD Ø 4 **P**
↓ 13 ↔ 7 cm.

ART. 22068SD Ø 4 **T**
↓ 13 ↔ 7 cm.



ART. 22970SD **P** ART. 22870SD **T**
↓ 17 ↔ 11 cm. ↓ 17 ↔ 11 cm.

ART. 22871SD
↓ 21 ↔ 14 cm.



ART. 29371SD P **P** ART. 29071SD P **T**
↓ 17 ↔ 16 cm. ↓ 17 ↔ 16 cm.

ART. 29370SD R/C ART. 29070SD R/C
↓ 17 ↔ 16 cm. ↓ 17 ↔ 16 cm.



ART. 29373SD P **P** ART. 29073SD P **T**
↓ 17 ↔ 31 cm. ↓ 17 ↔ 31 cm.

ART. 29372SD R/C ART. 29072SD R/C
↓ 17 ↔ 31 cm. ↓ 17 ↔ 31 cm.



mezza vaschetta **P**
ART. 29330SD P
↓ 16 ↔ 27 cm.



ART. 29068SD R **T**
↓ 13 ↔ 21 cm.

ART. 29069SD R
↓ 18 ↔ 30 cm.



ART. 29267SD R **P**
↓ 10 ↔ 11 cm.

ART. 29067SD R **T**
↓ 10 ↔ 11 cm.

Per ordinazioni aggiungere al codice articolo la lettera corrispondente alla colorazione scelta.

To place orders add to the article code the letter corresponding the selected colouring.

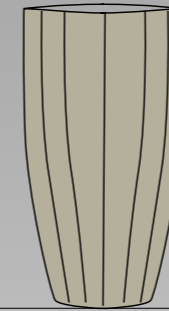

ART. 21071 R/C **T**
↓ 28 ↔ 15 cm.

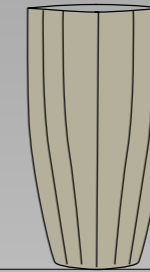

ART. 21272 P **P** ART. 21072 P **T**
↓ 20 ↔ 11 cm. ↓ 20 ↔ 11 cm.
ART. 21270 R/C ART. 21070 R/C
↓ 20 ↔ 11 cm. ↓ 20 ↔ 11 cm.

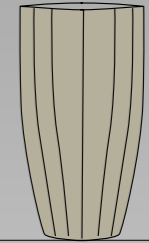

ART. 21264 P **P** ART. 21064 P **T**
↓ 17 ↔ 9 cm. ↓ 17 ↔ 9 cm.
ART. 21269 R/C ART. 21069 R/C
↓ 17 ↔ 9 cm. ↓ 17 ↔ 9 cm.
ART. 21268 R ART. 21068 R
↓ 13 ↔ 7 cm. ↓ 13 ↔ 7 cm.
ART. 21233 P ART. 21067 P
↓ 11 ↔ 7 cm. ↓ 11 ↔ 7 cm.



ART. 22071 Ø 6 **T**
↓ 24 ↔ 13 cm.



ART. 22270 Ø 5 **P**
↓ 19 ↔ 8 cm.
ART. 22070 Ø 5 **T**
↓ 19 ↔ 8 cm.



ART. 22268 Ø 4 **P**
↓ 13 ↔ 7 cm.
ART. 22068 Ø 4 **T**
↓ 13 ↔ 7 cm.

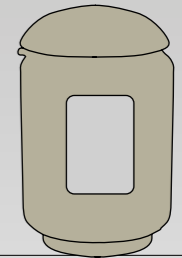

ART. 22970 4GG **P** ART. 22870 4GG **T**
↓ 17 ↔ 11 cm. ↓ 17 ↔ 11 cm.
ART. 22871 6GG
↓ 21 ↔ 14 cm.

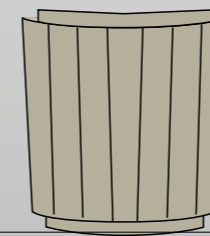

ART. 29371 P **P** ART. 29071 P **T**
↓ 17 ↔ 16 cm. ↓ 17 ↔ 16 cm.
ART. 29370 R/C ART. 29070 R/C
↓ 17 ↔ 16 cm. ↓ 17 ↔ 16 cm.

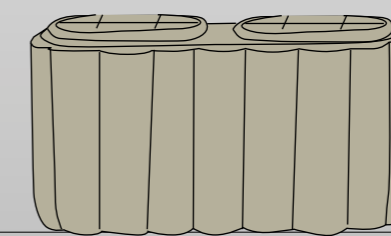

ART. 29373 P **P** ART. 29073 P **T**
↓ 17 ↔ 31 cm. ↓ 17 ↔ 31 cm.
ART. 29372 R/C ART. 29072 R/C
↓ 17 ↔ 31 cm. ↓ 17 ↔ 31 cm.

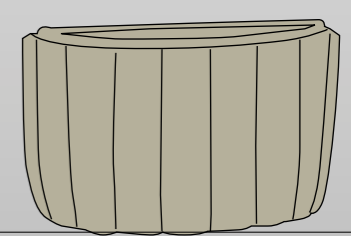

mezza vaschetta **P**
ART. 29330 P
↓ 16 ↔ 27 cm.

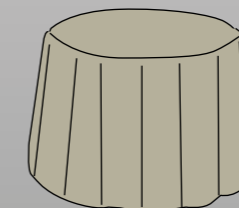

ART. 29068 R **T**
↓ 13 ↔ 21 cm.
ART. 29069 R
↓ 18 ↔ 30 cm.

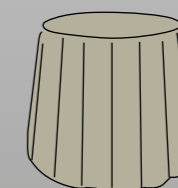

ART. 29267 R **P**
↓ 10 ↔ 11 cm.
ART. 29067 R **T**
↓ 10 ↔ 11 cm.



ART. 21071 R/C
↓ 28 ↔ 15 cm. **T**



ART. 21272 P
↓ 20 ↔ 11 cm. **P**

ART. 21072 P
↓ 20 ↔ 11 cm. **T**



ART. 21264 P
↓ 17 ↔ 9 cm. **P**

ART. 21064 P
↓ 17 ↔ 9 cm. **T**



ART. 21233 P
↓ 11 ↔ 7 cm. **P**

ART. 21067 P
↓ 11 ↔ 7 cm. **T**

ART. 21270 R/C
↓ 20 ↔ 11 cm. **P**

ART. 21070 R/C
↓ 20 ↔ 11 cm. **T**

ART. 21269 R/C
↓ 17 ↔ 9 cm. **P**

ART. 21069 R/C
↓ 17 ↔ 9 cm. **T**

ART. 21268 R
↓ 13 ↔ 7 cm. **P**

ART. 21068 R
↓ 13 ↔ 7 cm. **T**



ART. 29371 P
↓ 17 ↔ 16 cm. **P**

ART. 29071 P
↓ 17 ↔ 16 cm. **T**

ART. 22071 Ø 6
↓ 24 ↔ 13 cm. **T**

ART. 22270 Ø 5
↓ 19 ↔ 8 cm. **P**

ART. 22268 Ø 4
↓ 13 ↔ 7 cm. **P**

ART. 22970
↓ 17 ↔ 11 cm. **P**

ART. 22870
↓ 17 ↔ 11 cm. **T**

ART. 29370 R/C
↓ 17 ↔ 16 cm. **P**

ART. 29070 R/C
↓ 17 ↔ 16 cm. **T**

ART. 22070 Ø 5
↓ 19 ↔ 8 cm. **T**

ART. 22068 Ø 4
↓ 13 ↔ 7 cm. **T**

ART. 22871
↓ 21 ↔ 14 cm. **T**



ART. 29373 P
↓ 17 ↔ 31 cm. **P**

ART. 29073 P
↓ 17 ↔ 31 cm. **T**

ART. 29330 P
↓ 16 ↔ 27 cm. **P**

ART. 29068 R
↓ 13 ↔ 21 cm. **T**

ART. 29267 R
↓ 10 ↔ 11 cm. **P**

ART. 29372 R/C
↓ 17 ↔ 31 cm. **P**

ART. 29072 R/C
↓ 17 ↔ 31 cm. **T**

ART. 29069 R
↓ 18 ↔ 30 cm. **T**

ART. 29067 R
↓ 10 ↔ 11 cm. **T**



ART. 20318 7x9 cm.
ART. 20319 8x10 cm.
ART. 20320 9x12 cm.
ART. 20321 11x15 cm.
ART. 20322 13x18 cm.



ART. 20325 9x12 cm.
ART. 20326 10x15 cm.
ART. 20327 11x15 cm.
ART. 20328 13x18 cm.



ART. 20497 9x12 cm.
ART. 20498 11x15 cm.
ART. 20499 13x18 cm.



ART. 20536 9x12 cm.
ART. 20537 10x15 cm.
ART. 20538 11x15 cm.
ART. 20539 13x18 cm.



ART. 24102 ↓ 10 ↔ 6 cm.
ART. 24103 ↓ 15 ↔ 9 cm.
ART. 24104 ↓ 20 ↔ 11 cm.
ART. 24105 ↓ 30 ↔ 14 cm.
ART. 24106 ↓ 40 ↔ 15 cm.



ART. 21317 R/C **P** ART. 21015 R/C **T**
↓ 20 ↔ 11 cm. ↓ 28 ↔ 15 cm.
ART. 21319 R ART. 21017 R/C
↓ 17 ↔ 9 cm. ↓ 20 ↔ 11 cm.
ART. 21324 R ART. 21019 R
↓ 13 ↔ 7 cm. ↓ 17 ↔ 9 cm.
ART. 21023 R
↓ 13 ↔ 7 cm.



ART. 21313 R/C **P** ART. 21016 R/C **T**
↓ 20 ↔ 11 cm. ↓ 28 ↔ 15 cm.
ART. 21301 R ART. 21014 R/C
↓ 17 ↔ 9 cm. ↓ 20 ↔ 11 cm.
ART. 21308 R ART. 21021 R
↓ 13 ↔ 7 cm. ↓ 17 ↔ 9 cm.
ART. 21018 R
↓ 13 ↔ 7 cm.



ART. 22321 Ø 5 **P** ART. 22029 Ø 6 **T**
↓ 19 ↔ 8 cm. ↓ 24 ↔ 13 cm.
ART. 22309 Ø 4 ART. 22021 Ø 5
↓ 13 ↔ 7 cm. ↓ 19 ↔ 8 cm.
ART. 22009 Ø 4
↓ 13 ↔ 7 cm.



ART. 29516 R/C **P**
↓ 17 ↔ 16 cm.
ART. 29316 R/C **T**
↓ 17 ↔ 16 cm.



ART. 29513 R/C **P**
↓ 17 ↔ 16 cm.
ART. 29313 R/C **T**
↓ 17 ↔ 16 cm.



ART. 22313 Ø 5 **P** ART. 22008 Ø 6 **T**
↓ 19 ↔ 8 cm. ↓ 24 ↔ 13 cm.
ART. 22301 Ø 4 ART. 22014 Ø 5
↓ 13 ↔ 7 cm. ↓ 19 ↔ 8 cm.
ART. 22041 Ø 4
↓ 13 ↔ 7 cm.



ART. 22904 **P** ART. 22804 **T**
↓ 17 ↔ 11 cm. ↓ 17 ↔ 11 cm.
ART. 22805
↓ 21 ↔ 14 cm.



ART. 29518 R/C **P**
↓ 17 ↔ 31 cm.
ART. 29318 R/C **T**
↓ 17 ↔ 31 cm.



ART. 29521 R **P** ART. 29323 R **T**
↓ 10 ↔ 11 cm. ↓ 18 ↔ 30 cm.
ART. 29322 R
↓ 13 ↔ 21 cm.
ART. 29321 P
↓ 10 ↔ 11 cm.



ART. 29527 R **P** ART. 29329 R **T**
↓ 10 ↔ 11 cm. ↓ 18 ↔ 30 cm.
ART. 29328 R
↓ 13 ↔ 21 cm.
ART. 29327 P
↓ 10 ↔ 11 cm.



ART. 29512 R/C **P**
↓ 17 ↔ 31 cm.
ART. 29312 R/C **T**
↓ 17 ↔ 31 cm.



ART. 22932 **P** ART. 22831 **T**
↓ 17 ↔ 11 cm. ↓ 17 ↔ 11 cm.
ART. 22832
↓ 21 ↔ 14 cm.



ART. 20355 7x9 cm.
ART. 20356 8x10 cm.
ART. 20357 9x12 cm.
ART. 20358 11x15 cm.
ART. 20359 13x18 cm.



ART. 20360 9x12 cm.
ART. 20361 10x15 cm.
ART. 20362 11x15 cm.
ART. 20363 13x18 cm.



ART. 20540 9x12 cm.
ART. 20541 10x15 cm.
ART. 20542 13x15 cm.



ART. 20543 9x12 cm.
ART. 20544 10x15 cm.
ART. 20545 11x15 cm.
ART. 20546 13x18 cm.



ART. 24210 ↓ 10 ↔ 6 cm.
ART. 24211 ↓ 15 ↔ 9 cm.
ART. 24212 ↓ 20 ↔ 11 cm.
ART. 24213 ↓ 30 ↔ 14 cm.
ART. 24214 ↓ 40 ↔ 15 cm.



ART. 20391 7x9 cm.
ART. 20392 8x10 cm.
ART. 20393 9x12 cm.
ART. 20394 11x15 cm.
ART. 20395 13x18 cm.



ART. 20382 9x12 cm.
ART. 20383 10x15 cm.
ART. 20384 11x15 cm.
ART. 20385 13x18 cm.



ART. 20580 9x12 cm.
ART. 20581 11x15 cm.
ART. 20582 13x18 cm.



ART. 20561 9x12 cm.
ART. 20562 10x15 cm.
ART. 20563 11x15 cm.
ART. 20564 13x18 cm.



ART. 24225 ↓ 10 ↔ 6 cm.
ART. 24226 ↓ 15 ↔ 9 cm.
ART. 24227 ↓ 20 ↔ 11 cm.
ART. 24228 ↓ 30 ↔ 14 cm.
ART. 24229 ↓ 40 ↔ 15 cm.

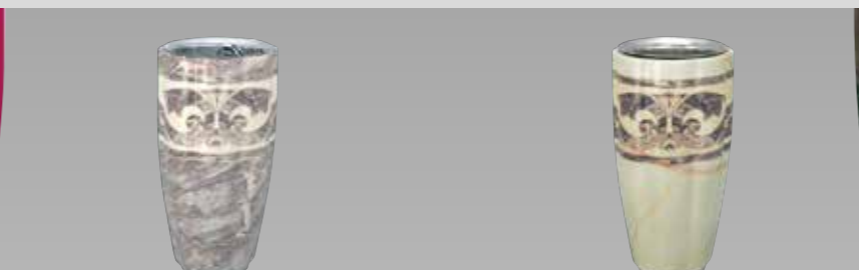

ART. 27304 R/C **P** ↓ 20 ↔ 11 cm.
ART. 27303 R/C ↓ 17 ↔ 9 cm.
ART. 27302 R/C ↓ 13 ↔ 7 cm.

ART. 27009 R/C **T** ↓ 28 ↔ 15 cm.
ART. 27004 R/C ↓ 20 ↔ 11 cm.
ART. 27003 R/C ↓ 17 ↔ 9 cm.
ART. 27002 R/C ↓ 13 ↔ 7 cm.

ART. 27320 R/C **P** ↓ 20 ↔ 11 cm.
ART. 27319 R/C ↓ 17 ↔ 9 cm.
ART. 27318 R/C ↓ 13 ↔ 7 cm.

ART. 27021 R/C **T** ↓ 28 ↔ 15 cm.
ART. 27020 R/C ↓ 20 ↔ 11 cm.
ART. 27019 R/C ↓ 17 ↔ 9 cm.
ART. 27018 R/C ↓ 13 ↔ 7 cm.

ART. 26312 Ø 5 **P** ↓ 19 ↔ 8 cm.
ART. 26314 Ø 4 ↓ 13 ↔ 7 cm.

ART. 26009 Ø 6 **T** ↓ 24 ↔ 13 cm.
ART. 26012 Ø 5 ↓ 19 ↔ 8 cm.
ART. 26014 Ø 4 ↓ 13 ↔ 7 cm.

ART. 29297 R/C **P** ↓ 17 ↔ 16 cm.
ART. 29054 R/C **T** ↓ 17 ↔ 16 cm.

ART. 29356 R/C **P** ↓ 17 ↔ 16 cm.
ART. 29056 R/C **T** ↓ 17 ↔ 16 cm.

ART. 26320 Ø 5 **P** ↓ 19 ↔ 8 cm.
ART. 26318 Ø 4 ↓ 13 ↔ 7 cm.

ART. 26021 Ø 6 **T** ↓ 24 ↔ 13 cm.
ART. 26020 Ø 5 ↓ 19 ↔ 8 cm.
ART. 26018 Ø 4 ↓ 13 ↔ 7 cm.



ART. 26903 **P** ↓ 17 ↔ 11 cm.
ART. 26803 **T** ↓ 17 ↔ 11 cm.
ART. 26802 ↓ 21 ↔ 14 cm.

ART. 29289 R/C **P** ↓ 17 ↔ 31 cm.
ART. 29055 R/C **T** ↓ 17 ↔ 31 cm.

ART. 29299 R **P** ↓ 10 ↔ 11 cm.
ART. 29031 R **T** ↓ 18 ↔ 30 cm.
ART. 29030 R ↓ 13 ↔ 21 cm.
ART. 29029 R ↓ 10 ↔ 11 cm.

ART. 29337 R **P** ↓ 10 ↔ 11 cm.
ART. 29039 R **T** ↓ 18 ↔ 30 cm.
ART. 29038 R ↓ 13 ↔ 21 cm.
ART. 29037 R ↓ 10 ↔ 11 cm.

ART. 29357 R/C **P** ↓ 17 ↔ 31 cm.
ART. 29057 R/C **T** ↓ 17 ↔ 31 cm.

ART. 26906 **P** ↓ 17 ↔ 11 cm.
ART. 26806 **T** ↓ 17 ↔ 11 cm.
ART. 26807 ↓ 21 ↔ 14 cm.



ART. 20800 7x9 cm.
ART. 20801 8x10 cm.
ART. 20802 9x12 cm.
ART. 20811 11x15 cm.
ART. 20812 13x18 cm.

ART. 20851 9x12 cm.
ART. 20857 10x15 cm.
ART. 20858 11x15 cm.
ART. 20859 13x18 cm.

ART. 20930 9x12 cm.
ART. 20931 11x15 cm.
ART. 20932 13x18 cm.

ART. 20933 9x12 cm.
ART. 20934 10x15 cm.
ART. 20935 11x15 cm.
ART. 20936 13x18 cm.

ART. 24265 ↓ 10 ↔ 6 cm.
ART. 24266 ↓ 15 ↔ 9 cm.
ART. 24267 ↓ 20 ↔ 11 cm.
ART. 24268 ↓ 30 ↔ 14 cm.
ART. 24269 ↓ 40 ↔ 15 cm.

ART. 20950 7x9 cm.
ART. 20951 8x10 cm.
ART. 20952 9x12 cm.
ART. 20953 11x15 cm.
ART. 20954 13x18 cm.

ART. 20955 9x12 cm.
ART. 20956 10x15 cm.
ART. 20957 11x15 cm.
ART. 20958 13x18 cm.

ART. 20959 9x12 cm.
ART. 20960 11x15 cm.
ART. 20961 13x18 cm.

ART. 20962 9x12 cm.
ART. 20963 10x15 cm.
ART. 20964 11x15 cm.
ART. 20965 13x18 cm.

ART. 24275 ↓ 10 ↔ 6 cm.
ART. 24276 ↓ 15 ↔ 9 cm.
ART. 24277 ↓ 20 ↔ 11 cm.
ART. 24278 ↓ 30 ↔ 14 cm.
ART. 24279 ↓ 40 ↔ 15 cm.



ART. 21029SD P **T**
↓ 29 ↔ 15 cm.



ART. 21007SD P **P**
↓ 22 ↔ 12 cm.
ART. 21027SD P **T**
↓ 22 ↔ 12 cm.



ART. 21009SD P **P**
↓ 19 ↔ 10 cm.
ART. 21207SD P **P**
↓ 13,5 ↔ 7,5 cm.



ART. 21028SD P **T**
↓ 19 ↔ 10 cm.
ART. 21025SD P **P**
↓ 13,5 ↔ 7,5 cm.
ART. 29212SD P **P**
↓ 18 ↔ 17 cm.
ART. 29112SD P **T**
↓ 18 ↔ 17 cm.



ART. 22106SD Ø 6 **T**
↓ 27 ↔ 13 cm.



ART. 22225SD Ø 5 **P**
↓ 22 ↔ 9 cm.
ART. 22105SD Ø 5 **T**
↓ 22 ↔ 9 cm.



ART. 22224SD Ø 5 **P**
↓ 19 ↔ 8 cm.
ART. 22222SD Ø 4 **P**
↓ 15 ↔ 7 cm.



ART. 22104SD Ø 5 **T**
↓ 19 ↔ 8 cm.
ART. 22132SD Ø 4 **P**
↓ 15 ↔ 7 cm.
ART. 22852 **T**
↓ 17 ↔ 11 cm.
ART. 22853 **T**
↓ 23 ↔ 15 cm.
ART. 22951 **P**
↓ 17 ↔ 11 cm.



ART. 20153 7x9 cm.
ART. 20154 8x10 cm.
ART. 20263 9x12 cm.
ART. 20264 11x15 cm.
ART. 20265 13x18 cm.



ART. 20323 7x9 cm.
ART. 20324 8x10 cm.
ART. 20345 9x12 cm.
ART. 20346 10x15 cm.
ART. 20347 11x15 cm.
ART. 20348 13x18 cm.



ART. 20898 9x12 cm.
ART. 20899 11x15 cm.
ART. 20900 13x18 cm.



ART. 20901 9x12 cm.
ART. 20902 10x15 cm.
ART. 20909 11x15 cm.
ART. 20910 13x18 cm.



ART. 24195 ↓ 10 ↔ 6 cm.
ART. 24196 ↓ 15 ↔ 9 cm.
ART. 24197 ↓ 20 ↔ 11 cm.
ART. 24198 ↓ 30 ↔ 14 cm.
ART. 24199 ↓ 40 ↔ 15 cm.

Per ordinazioni aggiungere al codice articolo la lettera corrispondente alla colorazione scelta.

To place orders add to the article code the letter corresponding the selected colouring.

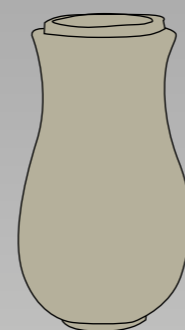

ART. 21076 P **T**
↓ 29 ↔ 15 cm.



ART. 21276 P **P** ART. 21077 P **T**
↓ 22 ↔ 12 cm. ↓ 22 ↔ 12 cm.

ART. 21277 P ART. 21078 P
↓ 19 ↔ 10 cm. ↓ 19 ↔ 10 cm.

ART. 21278 P ART. 21079 P
↓ 13,5 ↔ 7,5 cm. ↓ 13,5 ↔ 7,5 cm.

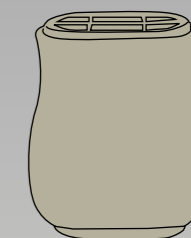

ART. 29275 P **P**
↓ 18 ↔ 17 cm.

ART. 29075 P **T**
↓ 18 ↔ 17 cm.

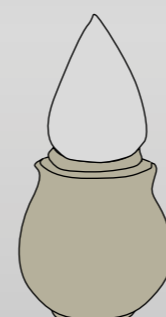

ART. 22076 Ø 6 **T**
↓ 27 ↔ 13 cm.

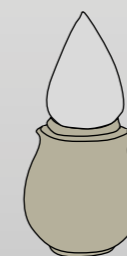

ART. 22277 Ø 5 **P** ART. 22077 Ø 5 **T**
↓ 19 ↔ 8 cm. ↓ 19 ↔ 8 cm.

ART. 22278 Ø 4 ART. 22078 Ø 4
↓ 15 ↔ 7 cm. ↓ 15 ↔ 7 cm.

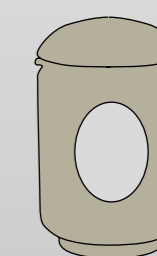

ART. 22935 **P** ART. 22852 **T**
↓ 17 ↔ 11 cm. ↓ 17 ↔ 11 cm.

ART. 22853
↓ 23 ↔ 15 cm.

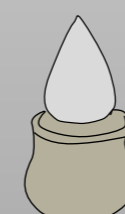

ART. 22251 Ø 5 **T**
↓ 16 ↔ 9,5 cm.

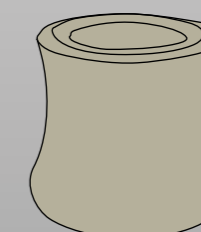

ART. 29251 R **T**
↓ 16 ↔ 17 cm.

ART. 29252 R
↓ 18 ↔ 19 cm.



ART. 21076 P **T**
↓ 29 ↔ 15 cm.



ART. 21276 P **P**
↓ 22 ↔ 19 cm.



ART. 21277 P **P**
↓ 19 ↔ 10 cm.



ART. 21278 P **P**
↓ 13,5 ↔ 7,5 cm.



ART. 29275 P **P**
↓ 18 ↔ 17 cm.

ART. 21077 P **T**
↓ 22 ↔ 19 cm.

ART. 21078 P **T**
↓ 19 ↔ 10 cm.

ART. 21079 P **T**
↓ 13,5 ↔ 7,5 cm.

ART. 29075 P **T**
↓ 18 ↔ 17 cm.



ART. 22076 Ø 6 **T**
↓ 27 ↔ 13 cm.



ART. 22277 Ø 5 **P**
↓ 19 ↔ 8 cm.



ART. 22278 Ø 4 **P**
↓ 15 ↔ 7 cm.



ART. 22241 Ø 5 **P**
↓ 21 ↔ 15 cm.



ART. 29241 **P**
↓ 19 ↔ 19 cm.

ART. 22077 Ø 5 **T**
↓ 19 ↔ 8 cm.

ART. 22078 Ø 4 **T**
↓ 15 ↔ 7 cm.



ART. 29251 R **T**
↓ 16 ↔ 17 cm.



ART. 22251 Ø 5 **T**
↓ 16 ↔ 9,5 cm.



ART. 22910 **P**
↓ 17 ↔ 11 cm.

ART. 22808 **T**
↓ 17 ↔ 11 cm.



ART. 21102 P **T**
↓ 6 ↔ 18 cm.



ART. 22102 Ø 5 **T**
↓ 6 ↔ 12 cm.

ART. 29252 R
↓ 18 ↔ 19 cm.

ART. 22809
↓ 23 ↔ 15 cm.



ART. 20373 7x9 cm.
ART. 20374 8x10 cm.
ART. 20375 9x12 cm.
ART. 20376 11x15 cm.
ART. 20377 13x18 cm.



ART. 20378 9x12 cm.
ART. 20379 10x15 cm.



ART. 20554 9x12 cm.
ART. 20555 11x15 cm.



ART. 20557 9x12 cm.
ART. 20558 10x15 cm.



ART. 24220 ↓ 10 ↔ 6 cm.
ART. 24221 ↓ 15 ↔ 9 cm.
ART. 24222 ↓ 20 ↔ 11 cm.
ART. 24223 ↓ 30 ↔ 14 cm.
ART. 24224 ↓ 40 ↔ 15 cm.

ART. 20381 13x18 cm.

ART. 20560 13x18 cm.



ART. 21197 P T
↓ 29 ↔ 22 cm.

ART. 21194 I
↓ 29 ↔ 22 cm.



ART. 21094 R T
↓ 21 ↔ 15 cm.

ART. 21098 P
↓ 18 ↔ 14 cm.

ART. 21097 R/C
↓ 18 ↔ 14 cm.



ART. 21020 P T
↓ 14 ↔ 11 cm.

ART. 21003 R/C
↓ 14 ↔ 11 cm.



ART. 29051 P T
↓ 19 ↔ 21 cm.

ART. 29050 R/C
↓ 19 ↔ 21 cm.



ART. 22039 Ø 6 T
↓ 27 ↔ 16 cm.

ART. 22037 Ø 5
↓ 20 ↔ 12 cm.



ART. 22035 Ø 4 T
↓ 14 ↔ 8 cm.



ART. 22843 T
↓ 17 ↔ 15 cm.

ART. 22844
↓ 23 ↔ 19 cm.



ART. 29053 P T
↓ 19 ↔ 36 cm.

ART. 29052 R/C
↓ 19 ↔ 36 cm.



ART. 20820 7x9 cm.
ART. 20821 8x10 cm.
ART. 20822 9x12 cm.
ART. 20823 11x15 cm.
ART. 20824 13x18 cm.



ART. 20825 9x12 cm.
ART. 20826 10x15 cm.
ART. 20827 11x15 cm.
ART. 20828 13x18 cm.



ART. 20586 9x12 cm.
ART. 20587 11x15 cm.
ART. 20588 13x18 cm.



ART. 20569 9x12 cm.
ART. 20570 10x15 cm.
ART. 20571 11x15 cm.
ART. 20572 13x18 cm.



ART. 24235 ↓ 10 ↔ 6 cm.
ART. 24236 ↓ 15 ↔ 9 cm.
ART. 24237 ↓ 20 ↔ 11 cm.
ART. 24238 ↓ 30 ↔ 14 cm.
ART. 24239 ↓ 40 ↔ 15 cm.



ART. 21239 R **P**
↓ 21 ↔ 15 cm.



ART. 21237 R/C **P**
↓ 17 ↔ 14 cm.
ART. 21236 P
↓ 17 ↔ 14 cm.



ART. 21235 R/C **P**
↓ 14 ↔ 11 cm.
ART. 21238 P
↓ 14 ↔ 11 cm.



ART. 29350 R/C **P**
↓ 18 ↔ 21 cm.
ART. 29351 P
↓ 18 ↔ 21 cm.



ART. 22237 Ø 5 **P**
↓ 20 ↔ 12 cm.



ART. 22235 Ø 4 **P**
↓ 14 ↔ 8 cm.



ART. 22943 **P**
↓ 16 ↔ 15 cm.
attacco dietro **P**



ART. 29352 R/C **P**
↓ 18 ↔ 36 cm.
ART. 29353 P
↓ 18 ↔ 36 cm.



ART. 20820 7x9 cm.
ART. 20821 8x10 cm.
ART. 20822 9x12 cm.
ART. 20823 11x15 cm.
ART. 20824 13x18 cm.



ART. 20825 9x12 cm.
ART. 20826 10x15 cm.
ART. 20827 11x15 cm.
ART. 20828 13x18 cm.



ART. 24235 ↓ 10 ↔ 6 cm.
ART. 24236 ↓ 15 ↔ 9 cm.
ART. 24237 ↓ 20 ↔ 11 cm.
ART. 24238 ↓ 30 ↔ 14 cm.
ART. 24239 ↓ 40 ↔ 15 cm.

Per ordinazioni Semply Color
aggiungere al codice articolo la lettera
corrispondente alla colorazione
scelta.
To place orders add to the article code
the letter corresponding the selected
colouring.



ART. 21291 P
↓ 20 ↔ 13 cm.

ART. 21084 P
↓ 20 ↔ 13 cm.

ART. 21290 I
↓ 20 ↔ 13 cm.

ART. 21085 I
↓ 20 ↔ 13 cm.

ART. 21087 P
↓ 28 ↔ 18 cm.

ART. 21086 I
↓ 28 ↔ 18 cm.

ART. 21534 R
↓ 29 ↔ 19 cm.

ART. 21533 R
↓ 21 ↔ 13 cm.

ART. 21532 R
↓ 18 ↔ 12 cm.

ART. 21531 P
↓ 11 ↔ 7 cm.

ART. 21263 R
↓ 21 ↔ 13 cm.

ART. 21262 R
↓ 18 ↔ 12 cm.

ART. 21234 P
↓ 11 ↔ 7 cm.

COLOR



ART. 29294 P
↓ 18 ↔ 17 cm.

ART. 29085 P
↓ 18 ↔ 17 cm.

ART. 22281 Ø5
↓ 20 ↔ 9 cm.

ART. 22084 Ø5
↓ 20 ↔ 9 cm.

ART. 29290 R/C
↓ 18 ↔ 17 cm.

ART. 29084 R/C
↓ 18 ↔ 17 cm.

ART. 22086 Ø6
↓ 26 ↔ 10 cm.



ART. 22852 4gg
↓ 17 ↔ 11 cm.

ART. 22853 6gg
↓ 21 ↔ 14 cm.

ART. 22935 4gg
↓ 17 ↔ 11 cm.

COLOR



ART. 22534 Ø6
↓ 27 ↔ 14 cm.

ART. 22533 Ø5
↓ 20 ↔ 10 cm.

ART. 22532 Ø4
↓ 13 ↔ 7 cm.

ART. 22333 Ø5
↓ 20 ↔ 10 cm.

ART. 22332 Ø4
↓ 13 ↔ 7 cm.

COLOR



ART. 29166 P
↓ 17 ↔ 28 cm.

ART. 26032 Ø5
↓ 20 ↔ 11 cm.

COLOR

COLOR

ART. 22951 P
↓ 17 ↔ 11 cm.

ART. 22852 T
↓ 17 ↔ 11 cm.

ART. 20153 7x9 cm.
ART. 20154 8x10 cm.
ART. 20263 9x12 cm.
ART. 20264 11x15 cm.
ART. 20265 13x18 cm.

ART. 20323 7x9 cm.
ART. 20324 8x10 cm.
ART. 20345 9x12 cm.
ART. 20346 10x15 cm.
ART. 20347 11x15 cm.
ART. 20348 13x18 cm.

ART. 24195 ↓ 10 ↔ 6 cm.
ART. 24196 ↓ 15 ↔ 9 cm.
ART. 24197 ↓ 20 ↔ 11 cm.
ART. 24198 ↓ 30 ↔ 14 cm.
ART. 24199 ↓ 40 ↔ 15 cm.

ART. 22534 Ø6
↓ 27 ↔ 14 cm.

ART. 22533 Ø5
↓ 20 ↔ 10 cm.

ART. 22532 Ø4
↓ 13 ↔ 7 cm.

ART. 22333 Ø5
↓ 20 ↔ 10 cm.

ART. 22332 Ø4
↓ 13 ↔ 7 cm.

ART. 29166 P
↓ 17 ↔ 28 cm.

ART. 26032 Ø5
↓ 20 ↔ 11 cm.

COLOR

COLOR

Per ordinazioni aggiungere al codice articolo la lettera corrispondente alla colorazione scelta.
To place orders add to the article code the letter corresponding the selected colouring.



ART. 27401 P
↓ 20 ↔ 10,5 cm.

ART. 27101 P
↓ 20 ↔ 10,5 cm.

ART. 27401 P
↓ 20 ↔ 10,5 cm.

ART. 27101 P
↓ 20 ↔ 10,5 cm.

ART. 27400 I
↓ 20 ↔ 10,5 cm.

ART. 27100 I
↓ 20 ↔ 10,5 cm.

ART. 27400 I
↓ 20 ↔ 10,5 cm.

ART. 27100 I
↓ 20 ↔ 10,5 cm.

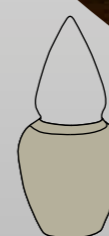
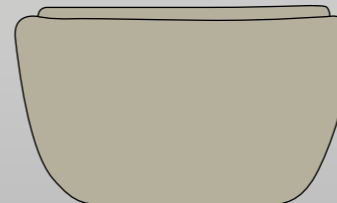
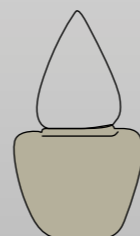

ART. 26401 Ø 5
↓ 19,5 ↔ 8,5 cm.

mezza vaschetta
ART. 29166 P
↓ 17 ↔ 28 cm.

mezza lampada
ART. 26032 Ø 5
↓ 20 ↔ 11 cm.

mezza lampada
ART. 26032 Ø 5
↓ 20 ↔ 11 cm.

mezza vaschetta
ART. 29166 P
↓ 17 ↔ 28 cm.

ART. 26401 Ø 5
↓ 19,5 ↔ 8,5 cm.

ART. 26101 Ø 5
↓ 19,5 ↔ 8,5 cm.

ART. 26101 Ø 5
↓ 19,5 ↔ 8,5 cm.

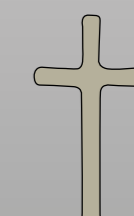
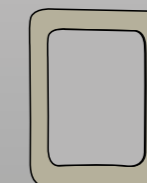
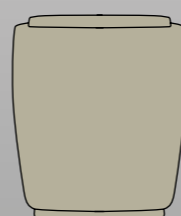

ART. 29425 P
↓ 19 ↔ 16 cm.

ART. 29121 P
↓ 19 ↔ 16 cm.

ART. 20153 7x9 cm.
ART. 20154 8x10 cm.
ART. 20263 9x12 cm.
ART. 20264 11x15 cm.
ART. 20265 13x18 cm.

ART. 20323 7x9 cm.
ART. 20324 8x10 cm.
ART. 20345 9x12 cm.
ART. 20346 10x15 cm.
ART. 20347 11x15 cm.
ART. 20348 13x18 cm.

ART. 24195 ↓ 10 ↔ 6 cm.
ART. 24196 ↓ 15 ↔ 9 cm.
ART. 24197 ↓ 20 ↔ 11 cm.
ART. 24198 ↓ 30 ↔ 14 cm.
ART. 24199 ↓ 40 ↔ 15 cm.

ART. 29425 P
↓ 19 ↔ 16 cm.

ART. 29121 P
↓ 19 ↔ 16 cm.

ART. 20153 7x9 cm.
ART. 20154 8x10 cm.
ART. 20263 9x12 cm.
ART. 20264 11x15 cm.
ART. 20265 13x18 cm.

ART. 20323 7x9 cm.
ART. 20324 8x10 cm.
ART. 20345 9x12 cm.
ART. 20346 10x15 cm.
ART. 20347 11x15 cm.
ART. 20348 13x18 cm.

ART. 24195 ↓ 10 ↔ 6 cm.
ART. 24196 ↓ 15 ↔ 9 cm.
ART. 24197 ↓ 20 ↔ 11 cm.
ART. 24198 ↓ 30 ↔ 14 cm.
ART. 24199 ↓ 40 ↔ 15 cm.

Per ordinazioni aggiungere al codice articolo la lettera corrispondente alla colorazione scelta.
To place orders add to the article code the letter corresponding the selected colouring.

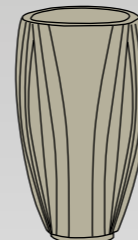

ART. 27603 P **P** ↓ 20,5 ↔ 11 cm.
ART. 27567 P **T** ↓ 20,5 ↔ 11 cm.
ART. 27601 I ↓ 20,5 ↔ 11 cm.
ART. 27566 I ↓ 20,5 ↔ 11 cm.

ART. 27603 P **P** ↓ 20,5 ↔ 11 cm.
ART. 27567 P **T** ↓ 20,5 ↔ 11 cm.
ART. 27601 I ↓ 20,5 ↔ 11 cm.
ART. 27566 I ↓ 20,5 ↔ 11 cm.

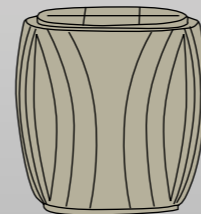

ART. 29581 P **P** ↓ 18 ↔ 16 cm.
ART. 29603 P **T** ↓ 18 ↔ 16 cm.
ART. 26626 Ø 5 **P** ↓ 21 ↔ 9 cm.
ART. 26127 Ø 5 **T** ↓ 21 ↔ 9 cm.
ART. 29580 R/C ↓ 18 ↔ 16 cm.
ART. 29602 R/C ↓ 18 ↔ 16 cm.

ART. 29581 P **P** ↓ 18 ↔ 16 cm.
ART. 29603 P **T** ↓ 18 ↔ 16 cm.
ART. 26626 Ø 5 **P** ↓ 21 ↔ 9 cm.
ART. 26127 Ø 5 **T** ↓ 21 ↔ 9 cm.
ART. 29580 R/C ↓ 18 ↔ 16 cm.
ART. 29602 R/C ↓ 18 ↔ 16 cm.

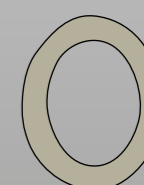
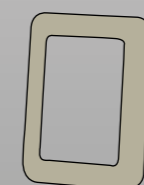
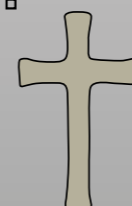

ART. 20153 7x9 cm.
ART. 20154 8x10 cm.
ART. 20263 9x12 cm.
ART. 20264 11x15 cm.
ART. 20265 13x18 cm.

ART. 20323 7x9 cm.
ART. 20324 8x10 cm.
ART. 20345 9x12 cm.
ART. 20346 10x15 cm.
ART. 20347 11x15 cm.
ART. 20348 13x18 cm.

ART. 24195 ↓ 10 ↔ 6 cm.
ART. 24196 ↓ 15 ↔ 9 cm.
ART. 24197 ↓ 20 ↔ 11 cm.
ART. 24198 ↓ 30 ↔ 14 cm.
ART. 24199 ↓ 40 ↔ 15 cm.

ART. 24195 ↓ 10 ↔ 6 cm.
ART. 24196 ↓ 15 ↔ 9 cm.
ART. 24197 ↓ 20 ↔ 11 cm.
ART. 24198 ↓ 30 ↔ 14 cm.
ART. 24199 ↓ 40 ↔ 15 cm.

ART. 20323 7x9 cm.
ART. 20324 8x10 cm.
ART. 20345 9x12 cm.
ART. 20346 10x15 cm.
ART. 20347 11x15 cm.
ART. 20348 13x18 cm.

ART. 20153 7x9 cm.
ART. 20154 8x10 cm.
ART. 20263 9x12 cm.
ART. 20264 11x15 cm.
ART. 20265 13x18 cm.

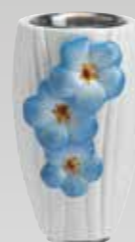

ART. 27646 P
↓ 20,5 ↔ 11 cm.

ART. 27802 P
↓ 20,5 ↔ 11 cm.

ART. 27648 P
↓ 20,5 ↔ 11 cm.

ART. 27804 P
↓ 20,5 ↔ 11 cm.

ART. 27645 I
↓ 20,5 ↔ 11 cm.

ART. 27801 I
↓ 20,5 ↔ 11 cm.

ART. 27647 I
↓ 20,5 ↔ 11 cm.

ART. 27803 I
↓ 20,5 ↔ 11 cm.



ART. 29576 R/C
↓ 18 ↔ 16 cm.

ART. 29641 R/C
↓ 18 ↔ 16 cm.

ART. 26628 Ø 5
↓ 21 ↔ 9 cm.

ART. 26131 Ø 5
↓ 21 ↔ 9 cm.

ART. 26629 Ø 5
↓ 21 ↔ 9 cm.

ART. 26135 Ø 5
↓ 21 ↔ 9 cm.

ART. 29574 R/C
↓ 18 ↔ 16 cm.

ART. 29643 R/C
↓ 18 ↔ 16 cm.

ART. 29577 P
↓ 18 ↔ 16 cm.

ART. 29642 P
↓ 18 ↔ 16 cm.

ART. 29575 P
↓ 18 ↔ 16 cm.

ART. 29644 P
↓ 18 ↔ 16 cm.



ART. 20153 7x9 cm.
ART. 20154 8x10 cm.
ART. 20263 9x12 cm.
ART. 20264 11x15 cm.
ART. 20265 13x18 cm.

ART. 20323 7x9 cm.
ART. 20324 8x10 cm.
ART. 20345 9x12 cm.
ART. 20346 10x15 cm.
ART. 20347 11x15 cm.
ART. 20348 13x18 cm.

ART. 24195 ↓ 10 ↔ 6 cm.
ART. 24196 ↓ 15 ↔ 9 cm.
ART. 24197 ↓ 20 ↔ 11 cm.
ART. 24198 ↓ 30 ↔ 14 cm.
ART. 24199 ↓ 40 ↔ 15 cm.

ART. 24195 ↓ 10 ↔ 6 cm.
ART. 24196 ↓ 15 ↔ 9 cm.
ART. 24197 ↓ 20 ↔ 11 cm.
ART. 24198 ↓ 30 ↔ 14 cm.
ART. 24199 ↓ 40 ↔ 15 cm.

ART. 20323 7x9 cm.
ART. 20324 8x10 cm.
ART. 20345 9x12 cm.
ART. 20346 10x15 cm.
ART. 20347 11x15 cm.
ART. 20348 13x18 cm.

ART. 20153 7x9 cm.
ART. 20154 8x10 cm.
ART. 20263 9x12 cm.
ART. 20264 11x15 cm.
ART. 20265 13x18 cm.



ART. 27644 P ↓ 20,5 ↔ 11 cm. ART. 27591 P ↓ 20,5 ↔ 11 cm.
ART. 27643 I ↓ 20,5 ↔ 11 cm. ART. 27590 I ↓ 20,5 ↔ 11 cm.

ART. 27650 P ↓ 20,5 ↔ 11 cm. ART. 27806 P ↓ 20,5 ↔ 11 cm.
ART. 27649 I ↓ 20,5 ↔ 11 cm. ART. 27805 I ↓ 20,5 ↔ 11 cm.



ART. 29579 P ↓ 18 ↔ 16 cm. ART. 29640 P ↓ 18 ↔ 16 cm. ART. 26627 Ø 5 ↓ 21 ↔ 9 cm. ART. 26129 Ø 5 ↓ 21 ↔ 9 cm.
ART. 29578 R/C ↓ 18 ↔ 16 cm. ART. 29639 R/C ↓ 18 ↔ 16 cm.



ART. 26630 Ø 5 ↓ 21 ↔ 9 cm. ART. 26177 Ø 5 ↓ 21 ↔ 9 cm. ART. 29598 P ↓ 18 ↔ 16 cm. ART. 29646 P ↓ 18 ↔ 16 cm.
ART. 29597 R/C ↓ 18 ↔ 16 cm. ART. 29645 R/C ↓ 18 ↔ 16 cm.



ART. 20153 7x9 cm.
ART. 20154 8x10 cm.
ART. 20263 9x12 cm.
ART. 20264 11x15 cm.
ART. 20265 13x18 cm.

ART. 20323 7x9 cm.
ART. 20324 8x10 cm.
ART. 20345 9x12 cm.
ART. 20346 10x15 cm.
ART. 20347 11x15 cm.
ART. 20348 13x18 cm.

ART. 24195 ↓ 10 ↔ 6 cm.
ART. 24196 ↓ 15 ↔ 9 cm.
ART. 24197 ↓ 20 ↔ 11 cm.
ART. 24198 ↓ 30 ↔ 14 cm.
ART. 24199 ↓ 40 ↔ 15 cm.

ART. 27652 P ↓ 20,5 ↔ 11 cm. ART. 27808 P ↓ 20,5 ↔ 11 cm.
ART. 27651 I ↓ 20,5 ↔ 11 cm. ART. 27807 I ↓ 20,5 ↔ 11 cm.

ART. 29555 P ↓ 18 ↔ 16 cm. ART. 29648 P ↓ 18 ↔ 16 cm.
ART. 29599 R/C ↓ 18 ↔ 16 cm. ART. 29647 R/C ↓ 18 ↔ 16 cm.

ART. 26631 Ø 5 ↓ 21 ↔ 9 cm. ART. 26221 Ø 5 ↓ 21 ↔ 9 cm.

Per ordinazioni aggiungere al codice articolo la lettera corrispondente alla colorazione scelta.
To place orders add to the article code the letter corresponding the selected colouring.

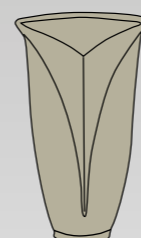

ART. 21279 P ART. 21092 P
↓ 21 ↔ 12 cm. ↓ 21 ↔ 12 cm.

ART. 21279 P ART. 21092 P
↓ 21 ↔ 12 cm. ↓ 21 ↔ 12 cm.

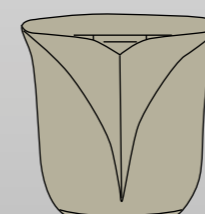

ART. 29880 P ART. 29728 P
↓ 19 ↔ 18 cm. ↓ 19 ↔ 18 cm.

ART. 22207 Ø 5
↓ 19 ↔ 9 cm.

ART. 22207 Ø 5
↓ 19 ↔ 9 cm.

ART. 29880 P ART. 29728 P
↓ 19 ↔ 18 cm. ↓ 19 ↔ 18 cm.

ART. 22004 Ø 5
↓ 19 ↔ 9 cm.

ART. 22004 Ø 5
↓ 19 ↔ 9 cm.

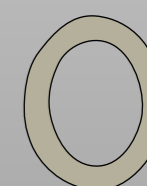
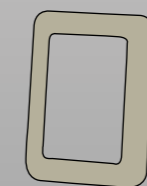
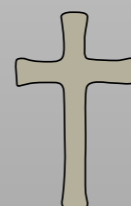

ART. 20618 7x9 cm.
ART. 20619 8x10 cm.
ART. 20620 9x12 cm.
ART. 20621 11x15 cm.
ART. 20622 13x18 cm.

ART. 20623 7x9 cm.
ART. 20624 8x10 cm.
ART. 20625 9x12 cm.
ART. 20626 10x15 cm.
ART. 20627 11x15 cm.
ART. 20628 13x18 cm.

ART. 24358 10x6 cm.
ART. 24359 15x9 cm.
ART. 24360 20x11 cm.
ART. 24361 30x14 cm.
ART. 24362 40x20 cm.

ART. 24358 10x6 cm.
ART. 24359 15x9 cm.
ART. 24360 20x11 cm.
ART. 24361 30x14 cm.
ART. 24362 40x20 cm.

ART. 20623 7x9 cm.
ART. 20624 8x10 cm.
ART. 20625 9x12 cm.
ART. 20626 10x15 cm.
ART. 20627 11x15 cm.
ART. 20628 13x18 cm.

ART. 20618 7x9 cm.
ART. 20619 8x10 cm.
ART. 20620 9x12 cm.
ART. 20621 11x15 cm.
ART. 20622 13x18 cm.

Per ordinazioni aggiungere al codice articolo la lettera corrispondente alla colorazione scelta.
To place orders add to the article code the letter corresponding the selected colouring.



ART. 21200 P ART. 21036 P
↓ 21 ↔ 12 cm. ↓ 21 ↔ 12 cm.

ART. 21200 P ART. 21036 P
↓ 21 ↔ 12 cm. ↓ 21 ↔ 12 cm.

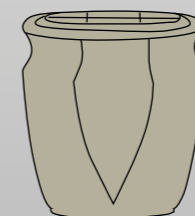

ART. 29287 P ART. 29000 P
↓ 19 ↔ 16 cm. ↓ 19 ↔ 16 cm.

ART. 22200 Ø 5
↓ 20 ↔ 9 cm.

ART. 22200 Ø 5
↓ 20 ↔ 9 cm.

ART. 29287 P ART. 29000 P
↓ 19 ↔ 16 cm. ↓ 19 ↔ 16 cm.

ART. 22002 Ø 5
↓ 20 ↔ 9 cm.

ART. 22002 Ø 5
↓ 20 ↔ 9 cm.

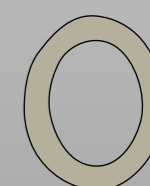
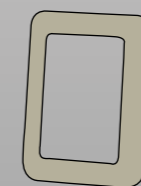
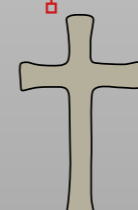

ART. 20618 7x9 cm.
ART. 20619 8x10 cm.
ART. 20620 9x12 cm.
ART. 20621 11x15 cm.
ART. 20622 13x18 cm.

ART. 20623 7x9 cm.
ART. 20624 8x10 cm.
ART. 20625 9x12 cm.
ART. 20626 10x15 cm.
ART. 20627 11x15 cm.
ART. 20628 13x18 cm.

ART. 24358 10x6 cm.
ART. 24359 15x9 cm.
ART. 24360 20x11 cm.
ART. 24361 30x14 cm.
ART. 24362 40x20 cm.

ART. 24358 10x6 cm.
ART. 24359 15x9 cm.
ART. 24360 20x11 cm.
ART. 24361 30x14 cm.
ART. 24362 40x20 cm.

ART. 20623 7x9 cm.
ART. 20624 8x10 cm.
ART. 20625 9x12 cm.
ART. 20626 10x15 cm.
ART. 20627 11x15 cm.
ART. 20628 13x18 cm.

ART. 20618 7x9 cm.
ART. 20619 8x10 cm.
ART. 20620 9x12 cm.
ART. 20621 11x15 cm.
ART. 20622 13x18 cm.

Per ordinazioni aggiungere al codice articolo la lettera corrispondente alla colorazione scelta.

To place orders add to the article code the letter corresponding the selected colouring.

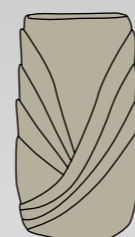

ART. 27330 P
↓ 19 ↔ 10 cm.

ART. 27117 P
↓ 27 ↔ 16,5 cm.

ART. 27116 P
↓ 20 ↔ 12 cm.

ART. 27330 P
↓ 19 ↔ 10 cm.

ART. 27117 P
↓ 27 ↔ 16,5 cm.

ART. 27116 P
↓ 20 ↔ 12 cm.

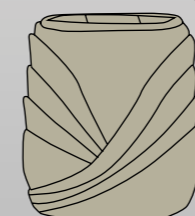
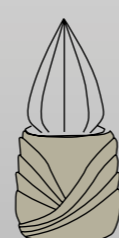

ART. 29376 P
↓ 17,5 ↔ 17 cm.

ART. 29145 P
↓ 17,5 ↔ 17 cm.

ART. 26330 Ø 5
↓ 20 ↔ 9,5 cm.

ART. 26116 Ø 5
↓ 20 ↔ 9,5 cm.

ART. 26330 Ø 5
↓ 20 ↔ 9,5 cm.

ART. 26116 Ø 5
↓ 20 ↔ 9,5 cm.

ART. 29376 P
↓ 17,5 ↔ 17 cm.

ART. 29145 P
↓ 17,5 ↔ 17 cm.

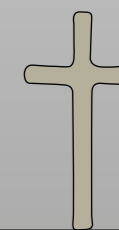
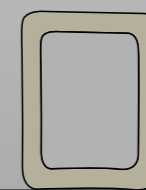
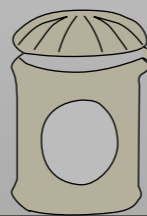

ART. 26913 P
↓ 17,5 ↔ 17 cm.

ART. 26872 T
↓ 17,5 ↔ 11 cm.

ART. 26873
↓ 21 ↔ 14 cm.

ART. 20618 7x9 cm.
ART. 20619 8x10 cm.
ART. 20620 9x12 cm.
ART. 20621 11x15 cm.
ART. 20622 13x18 cm.

ART. 20623 7x9 cm.
ART. 20624 8x10 cm.
ART. 20625 9x12 cm.
ART. 20626 10x15 cm.
ART. 20627 11x15 cm.
ART. 20628 13x18 cm.

ART. 24358 10x6 cm.
ART. 24359 15x9 cm.
ART. 24360 20x11 cm.
ART. 24361 30x14 cm.
ART. 24362 40x20 cm.

ART. 26913 P
↓ 17,5 ↔ 17 cm.

ART. 26872 T
↓ 17,5 ↔ 11 cm.

ART. 26873
↓ 21 ↔ 14 cm.

ART. 20618 7x9 cm.
ART. 20619 8x10 cm.
ART. 20620 9x12 cm.
ART. 20621 11x15 cm.
ART. 20622 13x18 cm.

ART. 20623 7x9 cm.
ART. 20624 8x10 cm.
ART. 20625 9x12 cm.
ART. 20626 10x15 cm.
ART. 20627 11x15 cm.
ART. 20628 13x18 cm.

ART. 24358 10x6 cm.
ART. 24359 15x9 cm.
ART. 24360 20x11 cm.
ART. 24361 30x14 cm.
ART. 24362 40x20 cm.

Per ordinazioni aggiungere al codice articolo la lettera corrispondente alla colorazione scelta.

To place orders add to the article code the letter corresponding the selected colouring.

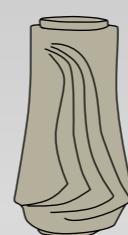

ART. 27285 P
↓ 20 ↔ 12 cm.

ART. 27086 P
↓ 29 ↔ 16 cm.

ART. 27085 P
↓ 20 ↔ 12 cm.

ART. 27285 P
↓ 20 ↔ 12 cm.

ART. 27086 P
↓ 29 ↔ 16 cm.

ART. 27085 P
↓ 20 ↔ 12 cm.

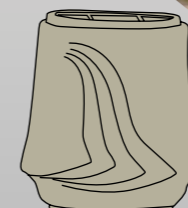
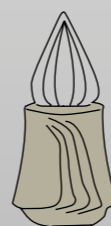

ART. 29203 P
↓ 19 ↔ 17 cm.

ART. 29103 P
↓ 19 ↔ 17 cm.

ART. 26285 Ø 5
↓ 20 ↔ 8,5 cm.

ART. 26085 Ø 5
↓ 20 ↔ 8,5 cm.

ART. 26285 Ø 5
↓ 20 ↔ 5,5 cm.

ART. 26085 Ø 5
↓ 20 ↔ 8,5 cm.

ART. 29203 P
↓ 19 ↔ 17 cm.

ART. 29103 P
↓ 19 ↔ 17 cm.

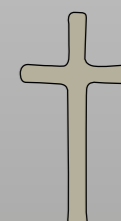
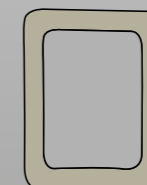
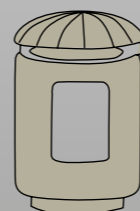

ART. 26901 P
↓ 17,5 ↔ 11 cm.

ART. 26801 T
↓ 17,5 ↔ 11 cm.

ART. 26831
↓ 21 ↔ 14 cm.

ART. 20618 7x9 cm.
ART. 20619 8x10 cm.
ART. 20620 9x12 cm.
ART. 20621 11x15 cm.
ART. 20622 13x18 cm.

ART. 20623 7x9 cm.
ART. 20624 8x10 cm.
ART. 20625 9x12 cm.
ART. 20626 10x15 cm.
ART. 20627 11x15 cm.
ART. 20628 13x18 cm.

ART. 24358 10x6 cm.
ART. 24359 15x9 cm.
ART. 24360 20x11 cm.
ART. 24361 30x14 cm.
ART. 24362 40x20 cm.

ART. 26901 P
↓ 17,5 ↔ 11 cm.

ART. 26801 T
↓ 17,5 ↔ 11 cm.

ART. 26831
↓ 21 ↔ 14 cm.

ART. 20618 7x9 cm.
ART. 20619 8x10 cm.
ART. 20620 9x12 cm.
ART. 20621 11x15 cm.
ART. 20622 13x18 cm.

ART. 20623 7x9 cm.
ART. 20624 8x10 cm.
ART. 20625 9x12 cm.
ART. 20626 10x15 cm.
ART. 20627 11x15 cm.
ART. 20628 13x18 cm.

ART. 24358 10x6 cm.
ART. 24359 15x9 cm.
ART. 24360 20x11 cm.
ART. 24361 30x14 cm.
ART. 24362 40x20 cm.

Per ordinazioni aggiungere al codice articolo la lettera corrispondente alla colorazione scelta.

To place orders add to the article code the letter corresponding to the selected colouring.



ART. 27291 P
↓ 20 ↔ 12 cm.

ART. 27091 P
↓ 20 ↔ 12 cm.

ART. 27291 P
↓ 20 ↔ 12 cm.

ART. 27091 P
↓ 20 ↔ 12 cm.

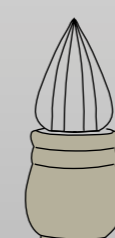

ART. 29335 P
↓ 18 ↔ 17 cm.

ART. 29128 P
↓ 18 ↔ 17 cm.

ART. 26292 Ø 5
↓ 20 ↔ 9 cm.

ART. 26092 Ø 5
↓ 20 ↔ 9 cm.

ART. 29335 P
↓ 19 ↔ 17 cm.

ART. 29128 P
↓ 19 ↔ 17 cm.

ART. 26292 Ø 5
↓ 20 ↔ 5,5 cm.

ART. 26092 Ø 5
↓ 20 ↔ 8,5 cm.

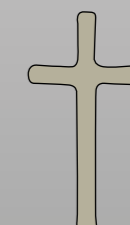
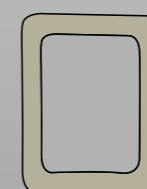

ART. 20618 7x9 cm.
ART. 20619 8x10 cm.
ART. 20620 9x12 cm.
ART. 20621 11x15 cm.
ART. 20622 13x18 cm.

ART. 20623 7x9 cm.
ART. 20624 8x10 cm.
ART. 20625 9x12 cm.
ART. 20626 10x15 cm.
ART. 20627 11x15 cm.
ART. 20628 13x18 cm.

ART. 24358 10x6 cm.
ART. 24359 15x9 cm.
ART. 24360 20x11 cm.
ART. 24361 30x14 cm.
ART. 24362 40x20 cm.

ART. 20618 7x9 cm.
ART. 20619 8x10 cm.
ART. 20620 9x12 cm.
ART. 20621 11x15 cm.
ART. 20622 13x18 cm.

ART. 20623 7x9 cm.
ART. 20624 8x10 cm.
ART. 20625 9x12 cm.
ART. 20626 10x15 cm.
ART. 20627 11x15 cm.
ART. 20628 13x18 cm.

ART. 24358 10x6 cm.
ART. 24359 15x9 cm.
ART. 24360 20x11 cm.
ART. 24361 30x14 cm.
ART. 24362 40x20 cm.

Per ordinazioni aggiungere al codice articolo la lettera corrispondente alla colorazione scelta.
To place orders add to the article code the letter corresponding the selected colouring.



ART. 27219 P ART. 27048 P
↓ 20 ↔ 12 cm. ↓ 20 ↔ 12 cm.

ART. 27219 P ART. 27048 P
↓ 20 ↔ 12 cm. ↓ 20 ↔ 12 cm.

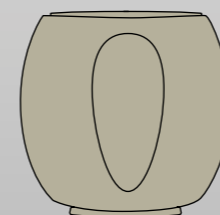
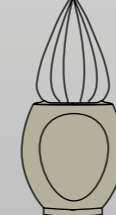

ART. 27218 P
↓ 13 ↔ 8 cm.

ART. 27045 P
↓ 13 ↔ 8 cm.

ART. 29334 P
↓ 17 ↔ 17,5 cm.

ART. 26238 Ø 5
↓ 20 ↔ 9,5 cm.

ART. 26238 Ø 5
↓ 20 ↔ 9,5 cm.

ART. 29334 P
↓ 17 ↔ 17,5 cm.

ART. 27218 P
↓ 13 ↔ 8 cm.

ART. 27045 P
↓ 13 ↔ 8 cm.

ART. 29074 P
↓ 17 ↔ 17,5 cm.

ART. 26035 Ø 5
↓ 20 ↔ 9,5 cm.

ART. 26035 Ø 5
↓ 20 ↔ 9,5 cm.

ART. 29074 P
↓ 17 ↔ 17,5 cm.

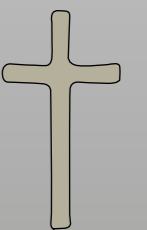
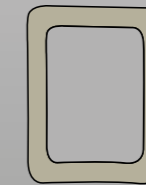
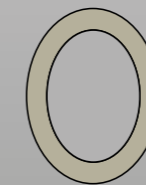

ART. 26234 Ø 4
↓ 13 ↔ 7 cm.

ART. 26034 Ø 4
↓ 13 ↔ 7 cm.

ART. 20618 7x9 cm.
ART. 20619 8x10 cm.
ART. 20620 9x12 cm.
ART. 20621 11x15 cm.
ART. 20622 13x18 cm.

ART. 20623 7x9 cm.
ART. 20624 8x10 cm.
ART. 20625 9x12 cm.
ART. 20626 10x15 cm.
ART. 20627 11x15 cm.
ART. 20628 13x18 cm.

ART. 24358 10x6 cm.
ART. 24359 15x9 cm.
ART. 24360 20x11 cm.
ART. 24361 30x14 cm.
ART. 24362 40x20 cm.

ART. 26234 Ø 4
↓ 13 ↔ 7 cm.

ART. 26034 Ø 4
↓ 13 ↔ 7 cm.

ART. 20618 7x9 cm.
ART. 20619 8x10 cm.
ART. 20620 9x12 cm.
ART. 20621 11x15 cm.
ART. 20622 13x18 cm.

ART. 20623 7x9 cm.
ART. 20624 8x10 cm.
ART. 20625 9x12 cm.
ART. 20626 10x15 cm.
ART. 20627 11x15 cm.
ART. 20628 13x18 cm.

ART. 24358 10x6 cm.
ART. 24359 15x9 cm.
ART. 24360 20x11 cm.
ART. 24361 30x14 cm.
ART. 24362 40x20 cm.



ART. 29519 P
↑19 ↔18 cm.

ART. 29019 P
↑19 ↔18 cm.



ART. 26519 Ø 5
↑21 ↔13,5 cm.

ART. 26119 Ø 5
↑21 ↔13,5 cm.



ART. 29227SD P
↑17 ↔18,5 cm.



ART. 22227SD Ø 5
↑19 ↔15,5 cm.



ART. 29562 P
↑19 ↔18 cm.

ART. 29002 T
↑19 ↔18 cm.



ART. 26563 P
Ø 5 ↑21 ↔13,5 cm.

ART. 26003 T
Ø 5 ↑21 ↔13,5 cm.



ART. 29332 P
↑16 ↔27 cm.



ART. 29227 P
↑17 ↔18,5 cm.



ART. 22227 Ø 5
↑19 ↔15,5 cm.

Per ordinazioni aggiungere al codice articolo la lettera corrispondente alla colorazione scelta.
To place orders add to the article code the letter corresponding the selected colouring.



ART. 29519 P
↑19 ↔18 cm.

ART. 29019 P
↑19 ↔18 cm.



ART. 26519 P
Ø 5 ↑21 ↔13,5 cm.

ART. 26119 T
Ø 5 ↑21 ↔13,5 cm.

Per ordinazioni aggiungere al codice articolo la lettera corrispondente alla colorazione scelta.
To place orders add to the article code the letter corresponding the selected colouring.

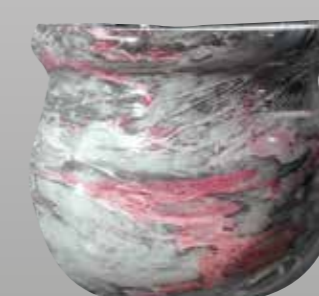

ART. 29227 P
↑17 ↔18,5 cm.



ART. 22227 Ø 5
↑19 ↔15,5 cm.



ART. 29467 P
↓ 19 ↔ 19 cm.

ART. 29077 P
↓ 19 ↔ 19 cm.



ART. 22467 Ø 5
↓ 21 ↔ 15 cm.

ART. 22067 Ø 5
↓ 21 ↔ 15 cm.



ART. 29467 P
↓ 19 ↔ 19 cm.

ART. 29077 P
↓ 19 ↔ 19 cm.



ART. 22467 Ø 5
↓ 21 ↔ 15 cm.

ART. 22067 Ø 5
↓ 21 ↔ 15 cm.



ART. 29419 P
↓ 19,5 ↔ 18,5 cm.



ART. 26419 Ø 5
↓ 20 ↔ 13,5 cm.



ART. 29419 P
↓ 19,5 ↔ 18,5 cm.



ART. 26419 Ø 5
↓ 20 ↔ 13,5 cm.



ART. 29414 P
↓ 20 ↔ 20 cm.



ART. 26414 Ø 5
↓ 20 ↔ 16 cm.

Per ordinazioni aggiungere al codice articolo la lettera corrispondente alla colorazione scelta.
To place orders add to the article code the letter corresponding the selected colouring.

Foto a titolo d'esempio



ART. 29414 P
↓ 20 ↔ 20 cm.

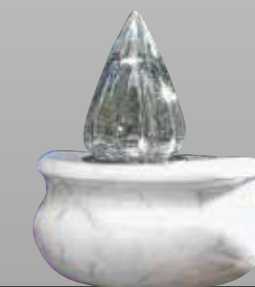

ART. 26414 Ø 5
↓ 20 ↔ 16 cm.



ART. 27476 P ↓ 11 ↔ 7 cm.	ART. 27579 P ↓ 13 ↔ 8 cm.	ART. 26616 Ø 4 ↓ 13 ↔ 7 cm.	ART. 27482 P ↓ 11 ↔ 7 cm.	ART. 27583 P ↓ 13 ↔ 8 cm.	ART. 26617 Ø 4 ↓ 13 ↔ 7 cm.	ART. 27480 P ↓ 11 ↔ 7 cm.	ART. 27575 P ↓ 13 ↔ 8 cm.	ART. 26613 Ø 4 ↓ 13 ↔ 7,5 cm.	ART. 27481 P ↓ 11 ↔ 7 cm.	ART. 27577 P ↓ 13 ↔ 8 cm.	ART. 26614 Ø 4 ↓ 13 ↔ 7,5 cm.
ART. 27624 P ↓ 13 ↔ 8 cm.	ART. 27578 R/C ↓ 13 ↔ 8 cm.	ART. 26150 Ø 4 ↓ 13 ↔ 7 cm.	ART. 27626 P ↓ 13 ↔ 8 cm.	ART. 27582 R/C ↓ 13 ↔ 8 cm.	ART. 26153 Ø 4 ↓ 13 ↔ 7 cm.	ART. 27620 P ↓ 13 ↔ 8 cm.	ART. 27574 R/C ↓ 13 ↔ 8 cm.	ART. 26148 Ø 4 ↓ 13 ↔ 7,5 cm.	ART. 27622 P ↓ 13 ↔ 8 cm.	ART. 27576 R/C ↓ 13 ↔ 8 cm.	ART. 26149 Ø 4 ↓ 13 ↔ 7,5 cm.
ART. 27623 R/C ↓ 13 ↔ 8 cm.			ART. 27625 R/C ↓ 13 ↔ 8 cm.			ART. 27619 R/C ↓ 13 ↔ 8 cm.			ART. 27621 R/C ↓ 13 ↔ 8 cm.		



ART. 27483 P ↓ 11 ↔ 7 cm.	ART. 27585 P ↓ 13 ↔ 8 cm.	ART. 26618 Ø 4 ↓ 13 ↔ 7 cm.	ART. 27484 P ↓ 11 ↔ 7 cm.	ART. 27587 P ↓ 13 ↔ 8 cm.	ART. 26619 Ø 4 ↓ 13 ↔ 7 cm.	ART. 27474 P ↓ 11 ↔ 7 cm.	ART. 27589 P ↓ 13 ↔ 8 cm.	ART. 26620 Ø 4 ↓ 13 ↔ 7 cm.	ART. 27485 P ↓ 11 ↔ 7 cm.	ART. 27593 P ↓ 13 ↔ 8 cm.	ART. 26621 Ø 4 ↓ 13 ↔ 7 cm.
ART. 27628 P ↓ 13 ↔ 8 cm.	ART. 27584 R/C ↓ 13 ↔ 8 cm.	ART. 26180 Ø 4 ↓ 13 ↔ 7 cm.	ART. 27630 P ↓ 13 ↔ 8 cm.	ART. 27586 R/C ↓ 13 ↔ 8 cm.	ART. 26182 Ø 4 ↓ 13 ↔ 7 cm.	ART. 27632 P ↓ 13 ↔ 8 cm.	ART. 27588 R/C ↓ 13 ↔ 8 cm.	ART. 26184 Ø 4 ↓ 13 ↔ 7 cm.	ART. 27634 P ↓ 13 ↔ 8 cm.	ART. 27592 R/C ↓ 13 ↔ 8 cm.	ART. 26297 Ø 4 ↓ 13 ↔ 7 cm.
ART. 27627 R/C ↓ 13 ↔ 8 cm.			ART. 27629 R/C ↓ 13 ↔ 8 cm.			ART. 27631 R/C ↓ 13 ↔ 8 cm.			ART. 27633 R/C ↓ 13 ↔ 8 cm.		



ART. 27475 P ↓ 11 ↔ 7 cm.	ART. 27565 P ↓ 13 ↔ 8 cm.	ART. 26601 Ø 4 ↓ 13 ↔ 7,5 cm.	ART. 27477 P ↓ 11 ↔ 7 cm.	ART. 27569 P ↓ 13 ↔ 8 cm.	ART. 26603 Ø 4 ↓ 13 ↔ 7,5 cm.	ART. 27488 P ↓ 11 ↔ 7 cm.	ART. 27599 P ↓ 13 ↔ 8 cm.	ART. 26624 Ø 4 ↓ 13 ↔ 7 cm.	ART. 27489 P ↓ 11 ↔ 7 cm.	ART. 27581 P ↓ 13 ↔ 8 cm.	ART. 26625 Ø 4 ↓ 13 ↔ 7 cm.
ART. 27607 P ↓ 13 ↔ 8 cm.	ART. 27564 R/C ↓ 13 ↔ 8 cm.	ART. 26144 Ø 4 ↓ 13 ↔ 7,5 cm.	ART. 27612 P ↓ 13 ↔ 8 cm.	ART. 27568 R/C ↓ 13 ↔ 8 cm.	ART. 26145 Ø 4 ↓ 13 ↔ 7,5 cm.	ART. 27640 P ↓ 13 ↔ 8 cm.	ART. 27598 R/C ↓ 13 ↔ 8 cm.	ART. 26502 Ø 4 ↓ 13 ↔ 7 cm.	ART. 27642 P ↓ 13 ↔ 8 cm.	ART. 27580 R/C ↓ 13 ↔ 8 cm.	ART. 26504 Ø 4 ↓ 13 ↔ 7 cm.
ART. 27606 R/C ↓ 13 ↔ 8 cm.			ART. 27609 R/C ↓ 13 ↔ 8 cm.			ART. 27639 R/C ↓ 13 ↔ 8 cm.			ART. 27641 R/C ↓ 13 ↔ 8 cm.		



ART. 26234 Ø 4 ↓ 13 ↔ 7 cm. P	ART. 27218 P ↓ 13 ↔ 8 cm. P	ART. 26336 Ø 4 ↓ 15 ↔ 7,5 cm. P	ART. 27336 R/C ↓ 13 ↔ 9 cm. P	ART. 27153 R/C ↓ 13 ↔ 9 cm. T	ART. 27344 P ↓ 11 ↔ 7 cm. P	ART. 22287 Ø 4 ↓ 14 ↔ 8 cm. P	ART. 21287 R/C ↓ 15 ↔ 10 cm. P	ART. 21384 P ↓ 11 ↔ 6 cm. P	ART. 22359 Ø 4 ↓ 14 ↔ 8 cm. P	ART. 21359 R/C ↓ 15 ↔ 10 cm. P	ART. 21371 P ↓ 11 ↔ 6 cm. P
ART. 26034 Ø 4 ↓ 13 ↔ 7 cm. T	ART. 27045 P ↓ 13 ↔ 8 cm. T	ART. 26344 Ø 4 ↓ 12,5 ↔ 6,5 cm. P	ART. 27337 P ↓ 13 ↔ 8 cm. P	ART. 27152 P ↓ 13 ↔ 8 cm. T		ART. 22183 Ø 4 ↓ 14 ↔ 8 cm. T	ART. 21187 R/C ↓ 15 ↔ 10 cm. T		ART. 22159 Ø 4 ↓ 14 ↔ 8 cm. T	ART. 21159 R/C ↓ 15 ↔ 10 cm. T	
		ART. 26152 Ø 4 ↓ 15 ↔ 7,5 cm. T									



ART. 26343 Ø 4 ↓ 15 ↔ 7,5 cm. P	ART. 27342 R/C ↓ 14 ↔ 8 cm. P	ART. 27180 R/C ↓ 14 ↔ 8 cm. T	ART. 27345 P ↓ 11,5 ↔ 6 cm. P	ART. 21202 P ↓ 11 ↔ 4,5 cm. P	ART. 22359SD Ø 4 ↓ 14 ↔ 8 cm. P	ART. 21359SD R/C ↓ 15 ↔ 10 cm. P	ART. 21371SD P ↓ 11 ↔ 6 cm. P
ART. 26345 Ø 4 ↓ 13 ↔ 6 cm. P	ART. 27343 P ↓ 14 ↔ 8 cm. P	ART. 27179 P ↓ 14 ↔ 8 cm. T			ART. 22159SD Ø 4 ↓ 14 ↔ 8 cm. T	ART. 21159SD R/C ↓ 15 ↔ 10 cm. T	
ART. 26179 Ø 4 ↓ 15 ↔ 7,5 cm. T							



ART. 26436 Ø 4 ↓ 13 ↔ 7 cm. P	ART. 27436 R/C ↓ 12 ↔ 7,5 cm. P	ART. 27137 R/C ↓ 12 ↔ 7,5 cm. T	ART. 27438 P ↓ 11 ↔ 6,5 cm. P	ART. 22235SD Ø 4 ↓ 14 ↔ 8 cm. P	ART. 21235SD R/C ↓ 14 ↔ 11 cm. P	ART. 21003SD R/C ↓ 14 ↔ 11 cm. T	ART. 22235 Ø 4 ↓ 14 ↔ 8 cm. P	ART. 21235 R/C ↓ 14 ↔ 11 cm. P	ART. 21003 R/C ↓ 14 ↔ 11 cm. T
ART. 26137 Ø 4 ↓ 13 ↔ 7 cm. T	ART. 27437 P ↓ 12 ↔ 7,5 cm. P	ART. 27138 P ↓ 12 ↔ 7,5 cm. T		ART. 22035SD Ø 4 ↓ 14 ↔ 8 cm. T	ART. 21238SD P ↓ 14 ↔ 11 cm. P	ART. 21020SD P ↓ 14 ↔ 11 cm. P	ART. 22035 Ø 4 ↓ 14 ↔ 8 cm. T	ART. 21238 P ↓ 14 ↔ 11 cm. P	ART. 21020 P ↓ 14 ↔ 11 cm. T



ART. 22243 Ø 4
↓ 14 ↔ 8 cm. **P**

ART. 22418 Ø 4
↓ 14 ↔ 8 cm. **T**



ART. 21414 R
↓ 15 ↔ 9 cm. **T**

ART. 21417 P
↓ 15 ↔ 9 cm.

ART. 21246 R
↓ 15 ↔ 9 cm. **P**

ART. 21243 P
↓ 15 ↔ 9 cm.

ART. 21462 P
↓ 12 ↔ 5,5 cm. **P**



ART. 22249 Ø 4
↓ 12 ↔ 7,5 cm. **P**



ART. 21249 P
↓ 13 ↔ 7,5 cm. **P**



ART. 22222SD Ø 4
↓ 15 ↔ 7 cm. **P**

ART. 22132SD Ø 4
↓ 15 ↔ 7 cm. **T**



ART. 21207SD P
↓ 13,5 ↔ 7,5 cm. **P**

ART. 21025SD P
↓ 13,5 ↔ 7,5 cm. **T**



ART. 22278 Ø 4
↓ 15 ↔ 7 cm. **P**

ART. 22078 Ø 4
↓ 15 ↔ 7 cm. **T**



ART. 21278 P
↓ 13,5 ↔ 7,5 cm. **P**

ART. 21079 P
↓ 13,5 ↔ 7,5 cm. **T**



ART. 22319SD Ø 4
↓ 12 ↔ 7 cm. **P**

ART. 22119SD Ø 4
↓ 12 ↔ 7 cm. **T**



ART. 21318SD P
↓ 13 ↔ 7 cm. **P**

ART. 21119SD P
↓ 13 ↔ 7 cm. **T**



ART. 21190SD P
↓ 11 ↔ 6 cm. **P**



ART. 22319 Ø 4
↓ 12 ↔ 7 cm. **P**

ART. 22119 Ø 4
↓ 12 ↔ 7 cm. **T**



ART. 21318 P
↓ 13 ↔ 7 cm. **P**

ART. 21119 P
↓ 13 ↔ 7 cm. **T**



ART. 21190 P
↓ 11 ↔ 6 cm. **P**



ART. 22268SD Ø 4
↓ 13 ↔ 7 cm. **P**

ART. 22068SD Ø 4
↓ 13 ↔ 7 cm. **T**



ART. 21268SD R
↓ 13 ↔ 7 cm. **P**

ART. 21068SD R
↓ 13 ↔ 7 cm. **T**



ART. 21233SD P
↓ 11 ↔ 7 cm. **P**

ART. 21067SD P
↓ 11 ↔ 7 cm. **T**



ART. 22268 Ø 4
↓ 13 ↔ 7 cm. **P**

ART. 22068 Ø 4
↓ 13 ↔ 7 cm. **T**



ART. 21268 R
↓ 13 ↔ 7 cm. **P**

ART. 21068 R
↓ 13 ↔ 7 cm. **T**



ART. 21233 P
↓ 11 ↔ 7 cm. **P**

ART. 21067 P
↓ 11 ↔ 7 cm. **T**



ART. 22258 Ø 4
↓ 14 ↔ 8 cm. **P**

ART. 22518 Ø 4
↓ 14 ↔ 8 cm. **T**



ART. 21259 R/C
↓ 14 ↔ 8 cm. **P**

ART. 21258 P
↓ 14 ↔ 8 cm.

ART. 21519 R/C
↓ 14 ↔ 8 cm. **T**

ART. 21518 P
↓ 14 ↔ 8 cm.



ART. 22332 Ø 4
↓ 13 ↔ 7 cm. **P**

ART. 22532 Ø 4
↓ 13 ↔ 7 cm. **T**



ART. 21234 P
↓ 11 ↔ 7 cm. **P**

ART. 21531 P
↓ 11 ↔ 7 cm. **T**



ART. 26314 Ø 4
↓ 13 ↔ 7 cm. **P**

ART. 26014 Ø 4
↓ 13 ↔ 7 cm. **T**



ART. 27302 R/C
↓ 13 ↔ 7 cm. **P**

ART. 27002 R/C
↓ 13 ↔ 7 cm. **T**



ART. 26318 Ø 4
↓ 13 ↔ 7 cm. **P**

ART. 26018 Ø 4
↓ 13 ↔ 7 cm. **T**



ART. 27318 R/C
↓ 13 ↔ 7 cm. **P**

ART. 27018 R/C
↓ 13 ↔ 7 cm. **T**

Queste cornici sono disponibili anche in tutte le colorazioni marmi e graniti. Per ordinazione aggiungere al codice della cornice bianca la lettera corrispondente alla colorazione scelta.



ART. 22309 Ø 4 P
↓ 13 ↔ 7 cm.

ART. 21324 R P
↓ 13 ↔ 7 cm.

ART. 22301 Ø 4 P
↓ 13 ↔ 7 cm.

ART. 21308 R P
↓ 13 ↔ 7 cm.

ART. 22009 Ø 4 T
↓ 13 ↔ 7 cm.

ART. 21023 R T
↓ 13 ↔ 7 cm.

ART. 22041 Ø 4 T
↓ 13 ↔ 7 cm.

ART. 21018 R T
↓ 13 ↔ 7 cm.



PR. LEGA BRONZO P
ART. 0152 Ø 4
↓ 14 ↔ 7 cm.

PR. LEGA BRONZO T
ART. 0114 Ø 4
↓ 14 ↔ 7 cm.

PR. LEGA BRONZO P
ART. 0054 R
↓ 14 ↔ 8 cm.

PR. LEGA BRONZO T
ART. 0027 R
↓ 14 ↔ 8 cm.

ART. 0055 P
↓ 14 ↔ 8 cm.

ART. 0028 P
↓ 14 ↔ 8 cm.

PR. LEGA BRONZO P
ART. 0058 R/C
↓ 11 ↔ 6 cm.

PR. LEGA BRONZO T
ART. 0031 Ø 5
↓ 11 ↔ 6 cm.



INOX P
ART. 0153 Ø 4
↓ 14 ↔ 7 cm.

INOX T
ART. 0115 Ø 4
↓ 14 ↔ 7 cm.

INOX P
ART. 0056 R/C
↓ 14 ↔ 8 cm.

INOX T
ART. 0029 R/C
↓ 14 ↔ 8 cm.

ART. 0057 P
↓ 14 ↔ 8 cm.

ART. 0030 P
↓ 14 ↔ 8 cm.

INOX P
ART. 0063 P
↓ 11 ↔ 6 cm.

INOX T
ART. 0036 Ø 5
↓ 11 ↔ 6 cm.



Art. 20665 9x12 cm.
Art. 20666 11x15 cm.
Art. 20667 13x18 cm.

COLOR

Art. 20665 9x12 cm.
Art. 20666 11x15 cm.
Art. 20667 13x18 cm.

Art. 20668 9x12 cm.
Art. 20669 10x15 cm.
Art. 20670 11x15 cm.
Art. 20671 13x18 cm.

COLOR

Art. 20668 9x12 cm.
Art. 20669 10x15 cm.
Art. 20670 11x15 cm.
Art. 20671 13x18 cm.

ART. 20906 9x12 cm.
ART. 20907 11x15 cm.
ART. 20908 13x18 cm.

COLOR

ART. 20906 9x12 cm.
ART. 20907 11x15 cm.
ART. 20908 13x18 cm.

ART. 20916 9x12 cm.
ART. 20917 10x15 cm.
ART. 20918 11x15 cm.
ART. 20919 13x18 cm.

COLOR

ART. 20916 9x12 cm.
ART. 20917 10x15 cm.
ART. 20918 11x15 cm.
ART. 20919 13x18 cm.



ART. 20158 7x9 cm.
ART. 20159 8x10 cm.
ART. 20155 9x12 cm.
ART. 20156 11x15 cm.
ART. 20157 13x18 cm.

COLOR

ART. 20158 7x9 cm.
ART. 20159 8x10 cm.
ART. 20155 9x12 cm.
ART. 20156 11x15 cm.
ART. 20157 13x18 cm.

ART. 20166 9x12 cm.
ART. 20167 10x15 cm.
ART. 20168 11x15 cm.
ART. 20169 13x18 cm.

COLOR

ART. 20166 9x12 cm.
ART. 20167 10x15 cm.
ART. 20168 11x15 cm.
ART. 20169 13x18 cm.

ART. 20153 7x9 cm.
ART. 20154 8x10 cm.
ART. 20263 9x12 cm.
ART. 20264 11x15 cm.
ART. 20265 13x18 cm.

COLOR

ART. 20153 7x9 cm.
ART. 20154 8x10 cm.
ART. 20263 9x12 cm.
ART. 20264 11x15 cm.
ART. 20265 13x18 cm.

ART. 20323 7x9 cm.
ART. 20324 8x10 cm.
ART. 20345 9x12 cm.
ART. 20346 10x15 cm.
ART. 20347 11x15 cm.
ART. 20348 13x18 cm.

COLOR

ART. 20323 7x9 cm.
ART. 20324 8x10 cm.
ART. 20345 9x12 cm.
ART. 20346 10x15 cm.
ART. 20347 11x15 cm.
ART. 20348 13x18 cm.



ART. 20386 9x12 cm.
ART. 20387 11x15 cm.

COLOR

ART. 20386 9x12 cm.
ART. 20387 11x15 cm.

ART. 20113 9x12 cm.
ART. 20114 11x15 cm.
ART. 20115 13x18 cm.

COLOR

ART. 20113 9x12 cm.
ART. 20114 11x15 cm.
ART. 20115 13x18 cm.

Cornice tonda
ART. 20099 Ø 10 cm.

COLOR

ART. 20099 Ø 10 cm.



ART. 20160 9x12 cm.
ART. 20161 11x15 cm.
ART. 20162 13x18 cm.



ART. 20150 9x12 cm.
ART. 20151 11x15 cm.
ART. 20152 13x18 cm.



ART. 20401 7x9 cm.
ART. 20402 8x10 cm.
ART. 20410 9x12 cm.
ART. 20411 11x15 cm.
ART. 20412 13x18 cm.



ART. 20419 9x12 cm.
ART. 20420 10x15 cm.
ART. 20421 11x15 cm.
ART. 20422 13x18 cm.



ART. 24025 ↓ 10 ↔ 6 cm.
ART. 24026 ↓ 15 ↔ 9 cm.
ART. 24027 ↓ 20 ↔ 11 cm.
ART. 24028 ↓ 30 ↔ 14 cm.
ART. 24029 ↓ 40 ↔ 20 cm.

COLOR

ART. 24025 ↓ 10 ↔ 6 cm.
ART. 24026 ↓ 15 ↔ 9 cm.
ART. 24027 ↓ 20 ↔ 11 cm.
ART. 24028 ↓ 30 ↔ 14 cm.
ART. 24029 ↓ 40 ↔ 20 cm.



ART. 24195 ↓ 10 ↔ 6 cm.
ART. 24196 ↓ 15 ↔ 9 cm.
ART. 24197 ↓ 20 ↔ 11 cm.
ART. 24198 ↓ 30 ↔ 14 cm.
ART. 24199 ↓ 40 ↔ 20 cm.

COLOR

ART. 24195 ↓ 10 ↔ 6 cm.
ART. 24196 ↓ 15 ↔ 9 cm.
ART. 24197 ↓ 20 ↔ 11 cm.
ART. 24198 ↓ 30 ↔ 14 cm.
ART. 24199 ↓ 40 ↔ 20 cm.



SMALTO
BIANCO



SMALTO
BIANCO



ART. 20618 7x9 cm.
ART. 20619 8x10 cm.
ART. 20620 9x12 cm.
ART. 20621 11x15 cm.
ART. 20622 13x18 cm.

COLOR

ART. 20618 7x9 cm.
ART. 20619 8x10 cm.
ART. 20620 9x12 cm.
ART. 20621 11x15 cm.
ART. 20622 13x18 cm.

ART. 20623 7x9 cm.
ART. 20624 8x10 cm.
ART. 20625 9x12 cm.
ART. 20626 10x15 cm.
ART. 20627 11x15 cm.
ART. 20628 13x18 cm.

COLOR

ART. 20623 7x9 cm.
ART. 20624 8x10 cm.
ART. 20625 9x12 cm.
ART. 20626 10x15 cm.
ART. 20627 11x15 cm.
ART. 20628 13x18 cm.

ART. 20898 9x12 cm.
ART. 20899 11x15 cm.
ART. 20900 13x18 cm.

COLOR

ART. 20898 9x12 cm.
ART. 20899 11x15 cm.
ART. 20900 13x18 cm.

ART. 20901 9x12 cm.
ART. 20902 10x15 cm.
ART. 20909 11x15 cm.
ART. 20910 13x18 cm.

COLOR

ART. 20901 9x12 cm.
ART. 20902 10x15 cm.
ART. 20909 11x15 cm.
ART. 20910 13x18 cm.



SMALTO
BIANCO

ART. 24358 10x6 cm.
ART. 24359 15x9 cm.
ART. 24360 20x11 cm.
ART. 24361 30x14 cm.
ART. 24362 40x20 cm.

COLOR

ART. 24358 10x6 cm.
ART. 24359 15x9 cm.
ART. 24360 20x11 cm.
ART. 24361 30x14 cm.
ART. 24362 40x20 cm.



ART. 24322 20x11 cm.

COLOR

ART. 24322 20x11 cm.



ART. 20173 9x12 cm.
ART. 20174 11x15 cm.
ART. 20175 13x18 cm.



ART. 20170 9x12 cm.
ART. 20171 11x15 cm.
ART. 20172 13x18 cm.



Portaritratto inox con pergamena e cornice
ART. 20390
Preventivo a richiesta
Estimate on request



ART. 24020 ↓ 10 ↔ 6 cm.
ART. 24021 ↓ 15 ↔ 9 cm.
ART. 24022 ↓ 20 ↔ 11 cm.
ART. 24023 ↓ 25 ↔ 13 cm.
ART. 24024 ↓ 30 ↔ 14 cm.
ART. 24018 ↓ 45 ↔ 24 cm.



ART. 24035 ↓ 10 ↔ 6 cm.
ART. 24036 ↓ 15 ↔ 9 cm.
ART. 24037 ↓ 20 ↔ 11 cm.
ART. 24038 ↓ 30 ↔ 14 cm.
ART. 24069 ↓ 40 ↔ 15 cm.

Questi articoli sono disponibili anche in tutte le colorazioni marmi e graniti. Per ordinazione aggiungere al codice della cornice bianca la lettera corrispondente alla colorazione scelta.



* ART. 23000 Ø 4
* ART. 23001 Ø 5
COLOR
* ART. 23000 Ø 4
* ART. 23001 Ø 5



* ART. 23002 Ø 4
* ART. 23003 Ø 5
COLOR
* ART. 23002 Ø 4
* ART. 23003 Ø 5



ART. 23010 4x4 cm bianca
COLOR
ART. 23010 4x4 cm



ART. 22003 Ø 5
‡3,5 ↔ 7 cm.

* I prezzi delle borchie si intendono senza perni e sono predisposte di serie per il perno di Ø 5 MA - **ART. 91150**

Le borchie sopra rappresentate possono essere richieste nelle colorazioni marmi e graniti. Per ordinazioni aggiungere al codice articolo la lettera corrispondente alla colorazione scelta.

These studs can be requested in the colours of marble and granites. To place orders add to the article code the letter corresponding the selected colouring.



ART. 22292 Ø 8
‡ 90 ↔ 25 cm.



ART. 22304 Ø 8
‡ 90 ↔ 25 cm.



ART. 22290 Ø 8
‡ 90 ↔ 25 cm.

Staffe regolabili in primaria lega con smaltatura bianca portanti per marmo cm. 1-2



ART. 30930BI



ART. 30931BI



ART. 30932BI

Perno di Ø 10 MA x 100 compreso nel prezzo





ART. 22302 Ø 8
‡ 90 ↔ 30 cm.



ART. 22294 Ø 6
‡ 53 ↔ 21 cm.



ART. 29014 R 
 ↓ 16 ↔ 22 cm.

ART. 29005 R
 ↓ 17 ↔ 31 cm. 



ART. 21450 I 
 ↓ 6,5 ↔ 20 cm.

ART. 21451 P
 ↓ 6,5 ↔ 20 cm. 



ART. 22451 Ø 5 
 ↓ 6,5 ↔ 15 cm.



ART. 21116 I 
 ↓ 6 ↔ 18 cm.



ART. 22116 Ø 5 
 ↓ 16 ↔ 12 cm.

Per possibili varianti, vedi serie corrispondenti.
 For possible changes, see the corresponding series.

A richiesta:
 - con decoro
 - colorazioni marmi e graniti



ART. 29023 R 
 ↓ 14 ↔ 27,5 cm.





ART. 29024 R 
 ↓ 14 ↔ 27,5 cm.



ART. 21002 I 
 ↓ 13 ↔ 20 cm.



ART. 21458 I 
 ↓ 5 ↔ 17 cm.

ART. 21459 P
 ↓ 5 ↔ 17 cm. 



ART. 22458 Ø 5
 ↓ 14 ↔ 9,5 cm.

TARGHE

Madonna

TARGHE

Madonna

Targhe fino a h. cm. 30 - COLOR PARZIALE (bordo) + 40% - COLOR TOTALE + 100%
 Targhe oltre h. cm. 30 - SOLO COLOR PARZIALE (Bordo) + 40%



ART. 25194
 ↓ 13 ↔ 9 cm.



ART. 25008
 ↓ 13 ↔ 10 cm.
 ART. 25004
 ↓ 15 ↔ 11 cm.



ART. 25235
 ↓ 16 ↔ 10 cm.



ART. 25220
 ↓ 17 ↔ 9,5 cm.



ART. 25044
 ↓ 21 ↔ 21 cm.



ART. 25029
 ↓ 21 ↔ 15 cm.



ART. 25000
 ↓ 23 ↔ 15 cm.



ART. 25216
 ↓ 19,5 ↔ 12,5 cm.



ART. 25297
 ↓ 16 ↔ 11,5 cm.



Foto a titolo
 d'esempio

ART. 25297

Per ordinazioni aggiungere al codice
 articolo la lettera corrispondente alla
 colorazione scelta.

To place orders add to the article code
 the letter corresponding the selected
 colouring.



ART. 25536 Ø 5 cm.
 ART. 25537 Ø 10 cm.
 ART. 25538 Ø 15 cm.
 ART. 25539 Ø 20 cm.
 ART. 25540 Ø 25 cm.



ART. 25546 Ø 5 cm.
 ART. 25547 Ø 10 cm.
 ART. 25548 Ø 15 cm.
 ART. 25549 Ø 20 cm.
 ART. 25550 Ø 25 cm.

A RICHIESTA E' POSSIBILE RICHIEDERE ALTRE FIGURE PREVIO PREVENTIVO



ART. 25556 Ø 6 cm.
 ART. 25557 Ø 13 cm.



ART. 25028
 ↓ 16 ↔ 16 cm.



ART. 25010
 ↓ 16 ↔ 16 cm.



ART. 25541 Ø 5 cm.
 ART. 25542 Ø 10 cm.
 ART. 25543 Ø 15 cm.
 ART. 25544 Ø 20 cm.
 ART. 25545 Ø 25 cm.



ART. 25551 Ø 5 cm.
 ART. 25552 Ø 10 cm.
 ART. 25553 Ø 15 cm.
 ART. 25554 Ø 20 cm.
 ART. 25555 Ø 25 cm.



ART. 25221
↓ 25 ↔ 14,5 cm.



ART. 25291
↓ 27 ↔ 22 cm.



ART. 25018
↓ 20 ↔ 16 cm.
ART. 25024
↓ 28 ↔ 26 cm.



ART. 25022
↓ 37 ↔ 18 cm.



ART. 25021
↓ 40 ↔ 16 cm.



ART. 25111
↓ 40 ↔ 19 cm.



ART. 25045
↓ 29 ↔ 15,5 cm.



ART. 25186
↓ 30 ↔ 20 cm.



ART. 25106
↓ 33 ↔ 31 cm.



ART. 25032
↓ 33 ↔ 25 cm.



ART. 25229
↓ 35 cm.



ART. 25181
↓ 37 ↔ 12 cm.



ART. 25177
↓ 40 ↔ 34 cm.



ART. 25038
↓ 49 ↔ 15 cm.



ART. 25196
↓ 77 ↔ 26 cm.



ART. 25219
↓ 13 ↔ 9 cm.



ART. 25007
↓ 13 ↔ 9 cm.
ART. 25003
↓ 15 ↔ 11 cm.



ART. 25234
↓ 16 ↔ 11 cm.



ART. 25231
↓ 16,5 ↔ 9 cm.



ART. 25017
↓ 20 ↔ 16 cm.



ART. 25001
↓ 23 ↔ 15 cm.



ART. 25230
↓ 25 ↔ 14 cm.



ART. 25215
↓ 19,5 ↔ 12,5 cm.



ART. 25296
↓ 16 ↔ 11,5 cm.



ART. 25296
↓ 16 ↔ 11,5 cm.

Foto a titolo
d'esempio



ART. 25043
↓ 26 ↔ 21 cm.



ART. 25200
↓ 26 ↔ 18 cm.



ART. 25290
↓ 27 ↔ 20 cm.

Per ordinazioni aggiungere al codice articolo la lettera corrispondente alla colorazione scelta.

To place orders add to the article code the letter corresponding the selected colouring.



ART. 25528 Ø 6 cm.
ART. 25529 Ø 13 cm.



ART. 25027
↓ 16 ↔ 16 cm.



ART. 25012
↓ 16 ↔ 16 cm.



ART. 25046
↓ 27 ↔ 26 cm.



ART. 25023
↓ 28 ↔ 26 cm.



ART. 25201
↓ 34 ↔ 24 cm.



ART. 25031
↑ 33 ↔ 25 cm.

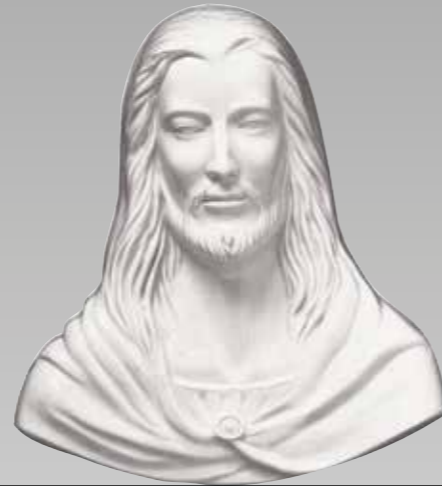

ART. 25107
↑ 35 ↔ 32 cm.



ART. 25202
↑ 48 ↔ 36 cm.



ART. 25039
↑ 49 ↔ 15 cm.



ART. 25037
↑ 36 ↔ 24,5 cm.



ART. 25183
↑ 37 ↔ 12 cm.





ART. 25114
↑ 42 ↔ 16 cm.



ART. 25195
↑ 77 ↔ 26 cm.



ART. 25180
↓ 85 ↔ 56 cm. 



ART. 25006
↓ 14 ↔ 15 cm.
ART. 25002
↓ 23 ↔ 24 cm.



ART. 25005
↓ 17 ↔ 15 cm.



ART. 25233
↓ 19 ↔ 10 cm.



ART. 25218
↓ 18 ↔ 17 cm.



ART. 25298
↓ 17 ↔ 17 cm.



ART. 25298
↓ 17 ↔ 17 cm.

Foto a titolo
d'esempio

Per ordinazioni aggiungere al codice articolo la lettera corrispondente alla colorazione scelta.

To place orders add to the article code the letter corresponding the selected colouring.



ART. 25232
↓ 25 ↔ 16 cm.



ART. 25184
↓ 27 ↔ 30 cm.
ART. 25185
↓ 32 ↔ 34 cm.

TARGHE
Particolare Pietà



ART. 25049
↑ 31 ↔ 50 cm.



ART. 25292
↑ 34 ↔ 31,5 cm.



ART. 25020
↑ 45 ↔ 25 cm.



ART. 25030
↑ 47 ↔ 42 cm.



ART. 25176
↑ 37 ↔ 20 cm.



ART. 25182
↑ 37 ↔ 12 cm.



ART. 25206
↑ 43 ↔ 43 cm.



ART. 25108
↑ 45 ↔ 32 cm.



ART. 25040
↑ 49 ↔ 15 cm.



ART. 25025
↑ 49 ↔ 16 cm.

TARGHE
Particolare Pietà



ART. 25173
↓ 6,5 ↔ 14 cm.
ART. 25174
↓ 8 ↔ 16 cm.



ART. 25034
↓ 11 ↔ 20 cm.



ART. 25247
↓ 12 ↔ 6 cm.



ART. 25248
↓ 12 ↔ 6 cm.



Angelo con Cornice destro
ART. 25036
↓ 9 ↔ 12 cm.



Angelo con Cornice sinistro
ART. 25019
↓ 9 ↔ 12 cm.

ART. 25558 Ø 5 cm.
ART. 25559 Ø 10 cm.
ART. 25560 Ø 15 cm.
ART. 25561 Ø 20 cm.
ART. 25562 Ø 25 cm.



ART. 25240
↓ 12 ↔ 14 cm.



ART. 25241
↓ 12 ↔ 14 cm.



ART. 25175
↓ 13 ↔ 13 cm.



ART. 25033
↓ 13,5 ↔ 9 cm.



ART. 25520 Ø 5 cm.
ART. 25521 Ø 10 cm.
ART. 25522 Ø 18 cm.
ART. 25523 Ø 25 cm.



ART. 25524 Ø 5 cm.
ART. 25525 Ø 10 cm.
ART. 25526 Ø 18 cm.
ART. 25527 Ø 25 cm.

TARGHE

TARGHE PADRE PIO



ART. 25295
 † 9,5 ↔ 11 cm.



ART. 25191
 † 13 ↔ 10 cm.



ART. 25192
 † 23 ↔ 11 cm.



ART. 25035
 † 34 ↔ 10 cm.



ART. 25278
 † 15 ↔ 11 cm.



ART. 25279
 † 15 ↔ 13,5 cm.



ART. 25280
 † 15 ↔ 11 cm.



ART. 25170
 † 7,5 ↔ 5 cm.

ART. 25171
 † 9 ↔ 6,5 cm.

ART. 25172
 † 12 ↔ 9 cm.



ART. 25238
 † 20 ↔ 12 cm.



ART. 25193
 † 21 ↔ 12 cm.



ART. 25239
 † 28 ↔ 21 cm.



ART. 25178
 † 30 ↔ 20 cm.



- ART. 25530** Ø 4 cm.
- ART. 25531** Ø 6 cm.
- ART. 25532** Ø 10 cm.
- ART. 25533** Ø 15 cm.
- ART. 25534** Ø 20 cm.
- ART. 25535** Ø 25 cm.



Med. Padre Pio
ART. 25269
 Ø 15 cm.



Med. Padre Pio
ART. 25209
 Ø 14,5 cm.



Med. Padre Pio
ART. 25268
 Ø 8 cm.



Med. Padre Pio
ART. 25267
 Ø 3 cm.



ART. 25563
Ø 5 cm.



ART. 25564
Ø 7 cm.



ART. 25565
Ø 10 cm.



ART. 25566
Ø 13 cm.



ART. 25567
Ø 15 cm.



ART. 25568
Ø 18 cm.

A RICHIESTA E' POSSIBILE RICHIEDERE ALTRE FIGURE PREVIO PREVENTIVO



Targa Madre Teresa di Calcutta
ART. 25244
↑ 14 ↔ 11 cm.



Med. San Francesco da Paola
ART. 25203
↑ 18 ↔ 13 cm.



Ultima Cena
ART. 25041
↑ 31 ↔ 50 cm.



San Giuseppe
ART. 25110
↑ 40 ↔ 14 cm.



Sant' Antonio
ART. 25109
↑ 40 ↔ 13 cm.

STATUE
Madonna

STATUE
Madonna



Busto
ART. 25050
↑ 20 ↔ 13 cm.



ART. 28020
↑ 21 ↔ 10 cm.



ART. 28003
↑ 25 ↔ 8 cm.



Busto
ART. 25199
↑ 34 ↔ 28 cm.



ART. 28005
↑ 60 ↔ 25 cm.



Madonna di Fatima
ART. 28007
↑ 68 ↔ 23 cm.



ART. 28014
↑ 42 ↔ 12 cm.



ART. 28004
↑ 43 ↔ 14 cm.



ART. 28008
↑ 52 ↔ 12 cm.



Madonna del Carmine
ART. 28026
↑ 80 ↔ 24 cm.



ART. 28010
↑ 80 ↔ 35 ↗ 25 cm.

STATUE

Madonna

STATUE

Cristo



Madonna di Lourdes
ART. 28035
↑ 83 ↔ 24 cm.



ART. 28022
↑ 84 ↔ 22 ↗ 19 cm.



Busto
ART. 25051
↑ 21 ↔ 17 cm.



ART. 28019
↑ 21 ↔ 10 cm.



ART. 28000
↑ 25 ↔ 8 cm.

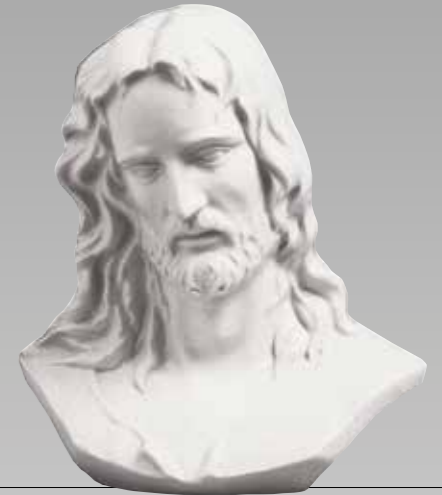

Busto
ART. 25198
↑ 34 ↔ 30 cm.



ART. 28001
↑ 43 ↔ 14 cm.



ART. 28002
↑ 60 ↔ 25 cm.



ART. 28011
↑ 80 ↔ 35 ↗ 26 cm.



ART. 28136 **P**
 ↓ 16 ↔ 10 cm.



ART. 28137 **P**
 ↓ 20 ↔ 10 cm.

A richiesta esiste la possibilità di inserire le iniziali sul libro con un aumento del 15%

ART. 28036 **T**
 ↓ 16 ↔ 10 cm.

ART. 28037 **T**
 ↓ 20 ↔ 10 cm.



Padre Pio
ART. 28016 Terreno
 ↓ 25 ↔ 8,5 cm.



Padre Pio
ART. 28116 Parete
 ↓ 25 ↔ 8,5 cm.



Statua
ART. 28032
 ↓ 18 ↔ 15 cm.



base 10x10
ART. 28023
 ↓ 26 ↔ 16,5 cm.



ART. 28012
 ↓ 20 ↔ 14 cm.



ART. 28006
 ↓ 37 ↔ 15 cm.



S. Antonio
ART. 28013
 ↓ 41 ↔ 12 cm.



Pietà di Michelangelo
ART. 28009
 ↓ 58 ↔ 45 ↗ 29 cm.



Padre Pio
ART. 28029
 ↓ 35 ↔ 12 ↗ 10 cm.



Padre Pio
ART. 28015 Terreno
 ↓ 53 ↔ 19 cm.



Padre Pio
ART. 28021
 ↓ 80 ↔ 24 ↗ 20 cm.

STATUE e TARGHE

decorate a mano su richiesta



STATUE e TARGHE

decorate a mano su richiesta

Preziose sculture policrome, con decori realizzati a mano dai nostri maestri decoratori.

La Vezzani SPA propone le targhe, i medaglioni e le statue in porcellana policroma, **su richiesta a preventivo.**

*Fine polychrome sculptures, with hand painted embellishments, created by our master decorators. Vezzani spa propose plates, photograph frames and statues in polychrome porcelain **on request with estimate.***

*Scultures précieuses polychromes, décorées à la main en relief par nos maîtres décorateurs. Vezzani spa propose des plaques, des médaillons et des statuettes en porcelaine polychrome, **sur demande et avec devis.***

*Wertvolle bunte Skulpturen mit meisterhaft handgearbeiteten Dekorationen. Fa. Vezzani bietet die Schilder, Medaillen und Statuen in buntem Porzellan **an. Angebot auf Anfrage.***

*Preciosas esculturas policromas, con decoraciones realizadas a mano por nuestros decoradores. La empresa Vezzani spa propone placas, medallones y estatuas en porcelana policroma, **con presupuesto bajo pedido.***

A B C D E F G
H K I J L M N
O P Q R S T U
V W X Y Z
1 2 3 4 5 6 7 8
9 0 * † - . , ' .

A B C D E F G
H K I J L M N
O P Q R S T U
V W X Y Z
1 2 3 4 5 6 7 8
9 0 * † - . , ' .

MISTRAL SENZA PERNO

ART. 5932	Lettere/Numeri/Stella/Croce	↓ mm.	30
ART. 5942	Lettere/Numeri/Stella/Croce	↓ mm.	40
ART. 5952	Lettere/Numeri/ Stella/Croce	↓ mm.	50
ART. 5981	Punto Accento/Virgola/Trattino	↓ mm.	30-40-50

MISTRAL con PERNO

ART. 5934	Lettere/Numeri/Stella/Croce	↓ mm.	30
ART. 5944	Lettere/Numeri/Stella/Croce	↓ mm.	40
ART. 5954	Lettere/Numeri/Stella/Croce	↓ mm.	50
ART. 5974	Lettere/Numeri	↓ mm.	70
ART. 5967	Punto/Accento/Virgola	x ↓ mm.	30/40/50
ART. 5967	Trattino	x ↓ mm.	30/40/50
ART. 5975	Punto/Accento/Virgola/Trattino	x ↓ mm.	70

Per composizioni epigrafi aumento del 20%

MISTRAL SENZA PERNO

ART. 5933	Lettere/Numeri/Stella/Croce	↓ mm.	30
ART. 5943	Lettere/Numeri/Stella/Croce	↓ mm.	40
ART. 5953	Lettere/Numeri/Stella/Croce	↓ mm.	50
ART. 5961	Punto Accento/Virgola/Trattino	↓ mm.	30-40-50

MISTRAL con PERNO

ART. 5935	Lettere/Numeri/Stella/Croce	↓ mm.	30
ART. 5945	Lettere/Numeri/Stella/Croce	↓ mm.	40
ART. 5957	Lettere/Numeri/Stella/Croce	↓ mm.	50
ART. 5970	Punto/Accento/Virgola	↓ mm.	30
ART. 5970	Trattino	↓ mm.	30/40/50

Per composizioni epigrafi aumento del 20%



CR
CREMA

ART. MCR34 ↓ mm. 30
ART. MCR44 ↓ mm. 40
ART. MCR54 ↓ mm. 50
ART. MCR74 ↓ mm. 70



BZ
BRONZO

ART. MBZ34 ↓ mm. 30
ART. MBZ44 ↓ mm. 40
ART. MBZ54 ↓ mm. 50
ART. MBZ74 ↓ mm. 70



E
VERDE

ART. ME34 ↓ mm. 30
ART. ME44 ↓ mm. 40
ART. ME54 ↓ mm. 50
ART. ME74 ↓ mm. 70



RI
RIGEL

ART. MRI34 ↓ mm. 30
ART. MRI44 ↓ mm. 40
ART. MRI54 ↓ mm. 50
ART. MRI74 ↓ mm. 70

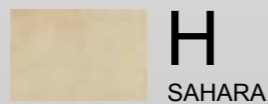

H
SAHARA

ART. MH34 ↓ mm. 30
ART. MH44 ↓ mm. 40
ART. MH54 ↓ mm. 50
ART. MH74 ↓ mm. 70



K
PINK

ART. MK34 ↓ mm. 30
ART. MK44 ↓ mm. 40
ART. MK54 ↓ mm. 50
ART. MK74 ↓ mm. 70



TR
TRANI

ART. MTR34 ↓ mm. 30
ART. MTR44 ↓ mm. 40
ART. MTR54 ↓ mm. 50
ART. MTR74 ↓ mm. 70



C
CARRARA

ART. MC34 ↓ mm. 30
ART. MC44 ↓ mm. 40
ART. MC54 ↓ mm. 50
ART. MC74 ↓ mm. 70



CL
CALIZIA

ART. MCL34 ↓ mm. 30
ART. MCL44 ↓ mm. 40
ART. MCL54 ↓ mm. 50
ART. MCL74 ↓ mm. 70



U
APUANIA

ART. MU34 ↓ mm. 30
ART. MU44 ↓ mm. 40
ART. MU54 ↓ mm. 50
ART. MU74 ↓ mm. 70



TU
TURKEY

ART. MTU34 ↓ mm. 30
ART. MTU44 ↓ mm. 40
ART. MTU54 ↓ mm. 50
ART. MTU74 ↓ mm. 70



RS
ROSA

ART. MRS34 ↓ mm. 30
ART. MRS44 ↓ mm. 40
ART. MRS54 ↓ mm. 50
ART. MRS74 ↓ mm. 70



Z
LABRADOR

ART. MZ34 ↓ mm. 30
ART. MZ44 ↓ mm. 40
ART. MZ54 ↓ mm. 50
ART. MZ74 ↓ mm. 70



R
ROMA

ART. MRU34 ↓ mm. 30
ART. MRU44 ↓ mm. 40
ART. MRU54 ↓ mm. 50
ART. MRU74 ↓ mm. 70



T
SARDINIA BETA

ART. MT34 ↓ mm. 30
ART. MT44 ↓ mm. 40
ART. MT54 ↓ mm. 50
ART. MT74 ↓ mm. 70



W
BETHEL WHITE

ART. MW34 ↓ mm. 30
ART. MW44 ↓ mm. 40
ART. MW54 ↓ mm. 50
ART. MW74 ↓ mm. 70



SY
SAHARA YELLOW

ART. MSY34 ↓ mm. 30
ART. MSY44 ↓ mm. 40
ART. MSY54 ↓ mm. 50
ART. MSY74 ↓ mm. 70

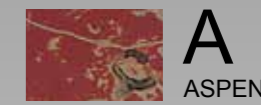

A
ASPEN

ART. MA34 ↓ mm. 30
ART. MA44 ↓ mm. 40
ART. MA54 ↓ mm. 50
ART. MA74 ↓ mm. 70



B
BLU

ART. MB34 ↓ mm. 30
ART. MB44 ↓ mm. 40
ART. MB54 ↓ mm. 50
ART. MB74 ↓ mm. 70



F
AFRICA

ART. MF34 ↓ mm. 30
ART. MF44 ↓ mm. 40
ART. MF54 ↓ mm. 50
ART. MF74 ↓ mm. 70



Y
ROSA DEL PORTOGALLO

ART. MY34 ↓ mm. 30
ART. MY44 ↓ mm. 40
ART. MY54 ↓ mm. 50
ART. MY74 ↓ mm. 70



L
ALPI

ART. ML34 ↓ mm. 30
ART. ML44 ↓ mm. 40
ART. ML54 ↓ mm. 50
ART. ML74 ↓ mm. 70



G
RED

ART. MG34 ↓ mm. 30
ART. MG44 ↓ mm. 40
ART. MG54 ↓ mm. 50
ART. MG74 ↓ mm. 70



JA
JAMAICA

ART. MJA34 ↓ mm. 30
ART. MJA44 ↓ mm. 40
ART. MJA54 ↓ mm. 50
ART. MJA74 ↓ mm. 70

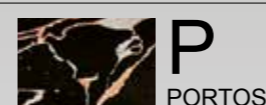

P
PORTOS

ART. MP34 ↓ mm. 30
ART. MP44 ↓ mm. 40
ART. MP54 ↓ mm. 50
ART. MP74 ↓ mm. 70



M
MELROSE

ART. MM34 ↓ mm. 30
ART. MM44 ↓ mm. 40
ART. MM54 ↓ mm. 50
ART. MM74 ↓ mm. 70

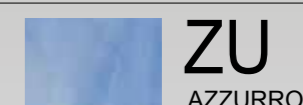

ZU
AZZURRO

ART. MZU34 ↓ mm. 30
ART. MZU44 ↓ mm. 40
ART. MZU54 ↓ mm. 50
ART. MZU74 ↓ mm. 70

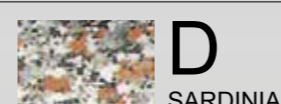

D
SARDINIA

ART. MD34 ↓ mm. 30
ART. MD44 ↓ mm. 40
ART. MD54 ↓ mm. 50
ART. MD74 ↓ mm. 70



Q
QUIN

ART. MQ34 ↓ mm. 30
ART. MQ44 ↓ mm. 40
ART. MQ54 ↓ mm. 50
ART. MQ74 ↓ mm. 70



RB
ROSA BELLISSIMO

ART. MRB34 ↓ mm. 30
ART. MRB44 ↓ mm. 40
ART. MRB54 ↓ mm. 50
ART. MRB74 ↓ mm. 70

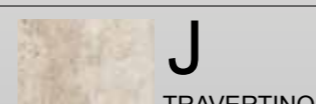

J
TRAVERTINO

ART. MJ34 ↓ mm. 30
ART. MJ44 ↓ mm. 40
ART. MJ54 ↓ mm. 50
ART. MJ74 ↓ mm. 70



NI
ONICE

ART. MNI34 ↓ mm. 30
ART. MNI44 ↓ mm. 40
ART. MNI54 ↓ mm. 50
ART. MNI74 ↓ mm. 70



CY
CAYMAN

ART. MCY34 ↓ mm. 30
ART. MCY44 ↓ mm. 40
ART. MCY54 ↓ mm. 50
ART. MCY74 ↓ mm. 70



VG
VERDE GUATEMALA

ART. MVG34 ↓ mm. 30
ART. MVG44 ↓ mm. 40
ART. MVG54 ↓ mm. 50
ART. MVG74 ↓ mm. 70

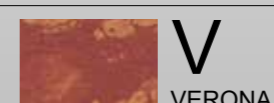

V
VERONA

ART. MV34 ↓ mm. 30
ART. MV44 ↓ mm. 40
ART. MV54 ↓ mm. 50
ART. MV74 ↓ mm. 70



S
SIERRA

ART. MS34 ↓ mm. 30
ART. MS44 ↓ mm. 40
ART. MS54 ↓ mm. 50
ART. MS74 ↓ mm. 70



RP
ROSA PORRINO

ART. MRP34 ↓ mm. 30
ART. MRP44 ↓ mm. 40
ART. MRP54 ↓ mm. 50
ART. MRP74 ↓ mm. 70



BM
BRONZO METALLIZZATO

ART. MBM34 ↓ mm. 30
ART. MBM44 ↓ mm. 40
ART. MBM54 ↓ mm. 50
ART. MBM74 ↓ mm. 70

PUNTEGGIATURA COLOR
ART. M968. Punto ↓ mm. 30
ART. M968- Trattino ↓ mm. 30
ART. M968, Virgola ↓ mm. 30
ART. M968' Accento ↓ mm. 30

A richiesta Arcadia con perno aumento 30%



Per composizioni epigrafi aumento del 20%

BIANCO
 ART. 5955 Lettere ↓ mm. 55
 ART. 5985 Pax ↓ mm. 55

NERO
 ART. 5956 Lettere ↓ mm. 55
 ART. 5986 Pax ↓ mm. 55

A richiesta Arcadia con perno aumento 30%

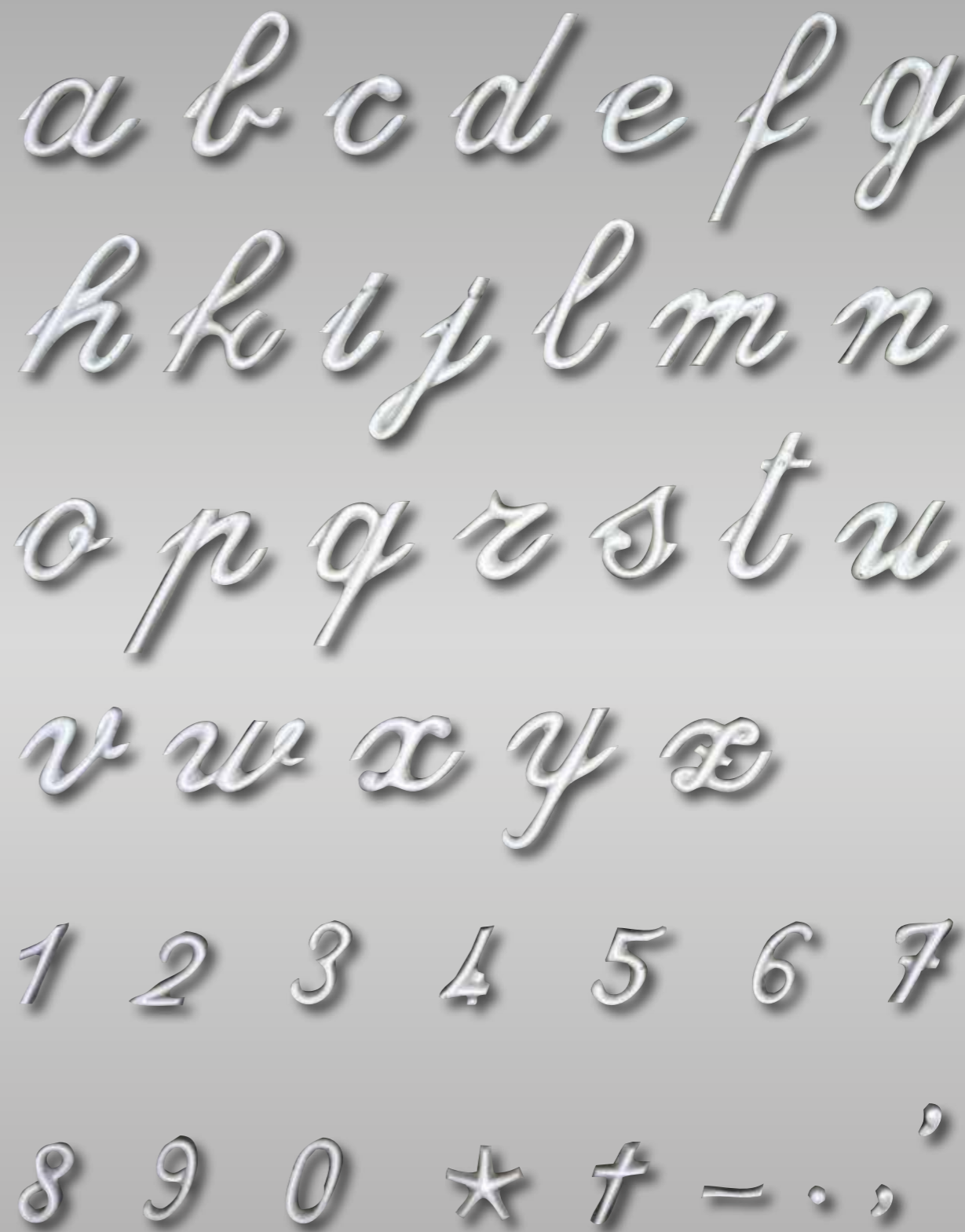

Per composizioni epigrafi aumento del 20%

BIANCO
 ART. 5930 Lettere/Numeri/Stella/Croce ↓ mm. 30
 ART. 5992 Accento ↓ mm. 30
 ART. 5996 Trattino ↓ mm. 30
 ART. 5997 Virgola ↓ mm. 30
 ART. 5999 Punto ↓ mm. 30

NERO
 ART. 5931 Lettere/Numeri/Stella/Croce ↓ mm. 30
 ART. 5991 Accento ↓ mm. 30
 ART. 5993 Trattino ↓ mm. 30
 ART. 5994 Virgola ↓ mm. 30
 ART. 5995 Punto ↓ mm. 30



<p>CREMA ART. ACR16 ↓mm. 80 ART. ACR17 ↓mm. 180 ART. ACR30 ↓mm. 30 ART. ACR55 ↓mm. 55 ART. ACR85 Pax</p>	<p>BRONZO ART. ABZ16 ↓mm. 80 ART. ABZ17 ↓mm. 180 ART. ABZ30 ↓mm. 30 ART. ABZ55 ↓mm. 55 ART. ABZ85 Pax</p>	<p>SAHARA ART. AH16 ↓mm. 80 ART. AH17 ↓mm. 180 ART. AH30 ↓mm. 30 ART. AH55 ↓mm. 55 ART. AH85 Pax</p>
<p>RIGEL ART. ARI16 ↓mm. 80 ART. ARI17 ↓mm. 180 ART. ARI30 ↓mm. 30 ART. ARI55 ↓mm. 55 ART. ARI85 Pax</p>	<p>TRANI ART. ATR16 ↓mm. 80 ART. ATR17 ↓mm. 180 ART. ATR30 ↓mm. 30 ART. ATR55 ↓mm. 55 ART. ATR85 Pax</p>	<p>CARRARA ART. AC16 ↓mm. 80 ART. AC17 ↓mm. 180 ART. AC30 ↓mm. 30 ART. AC55 ↓mm. 55 ART. AC85 Pax</p>
<p>APUANIA ART. AU16 ↓mm. 80 ART. AU17 ↓mm. 180 ART. AU30 ↓mm. 30 ART. AU55 ↓mm. 55 ART. AU85 Pax</p>	<p>TURKEY ART. ATU16 ↓mm. 80 ART. ATU17 ↓mm. 180 ART. ATU30 ↓mm. 30 ART. ATU55 ↓mm. 55 ART. ATU85 Pax</p>	<p>ROMA ART. AR16 ↓mm. 80 ART. AR17 ↓mm. 180 ART. AR30 ↓mm. 30 ART. AR55 ↓mm. 55 ART. AR85 Pax</p>
<p>LABRADOR ART. AZ16 ↓mm. 80 ART. AZ17 ↓mm. 180 ART. AZ30 ↓mm. 30 ART. AZ55 ↓mm. 55 ART. AZ85 Pax</p>	<p>BETHEL WHITE ART. AW16 ↓mm. 80 ART. AW17 ↓mm. 180 ART. AW30 ↓mm. 30 ART. AW55 ↓mm. 55 ART. AW85 Pax</p>	<p>SAHARA YELLOW ART. ASY16 ↓mm. 80 ART. ASY17 ↓mm. 180 ART. ASY30 ↓mm. 30 ART. ASY55 ↓mm. 55 ART. ASY85 Pax</p>

<p>SARDINIA BETA ART. AT16 ↓mm. 80 ART. AT17 ↓mm. 180 ART. AT30 ↓mm. 30 ART. AT55 ↓mm. 55 ART. AT85 Pax</p>	<p>ASPEN ART. AA16 ↓mm. 80 ART. AA17 ↓mm. 180 ART. AA30 ↓mm. 30 ART. AA55 ↓mm. 55 ART. AA85 Pax</p>	<p>PINK ART. AK16 ↓mm. 80 ART. AK17 ↓mm. 180 ART. AK30 ↓mm. 30 ART. AK55 ↓mm. 55 ART. AK85 Pax</p>
<p>VERDE ART. AE16 ↓mm. 80 ART. AE17 ↓mm. 180 ART. AE30 ↓mm. 30 ART. AE55 ↓mm. 55 ART. AE85 Pax</p>	<p>BLU ART. AB16 ↓mm. 80 ART. AB17 ↓mm. 180 ART. AB30 ↓mm. 30 ART. AB55 ↓mm. 55 ART. AB85 Pax</p>	<p>AFRICA ART. AF16 ↓mm. 80 ART. AF17 ↓mm. 180 ART. AF30 ↓mm. 30 ART. AF55 ↓mm. 55 ART. AF85 Pax</p>
<p>ALPI ART. AL16 ↓mm. 80 ART. AL17 ↓mm. 180 ART. AL30 ↓mm. 30 ART. AL55 ↓mm. 55 ART. AL85 Pax</p>	<p>RED ART. AG16 ↓mm. 80 ART. AG17 ↓mm. 180 ART. AG30 ↓mm. 30 ART. AG55 ↓mm. 55 ART. AG85 Pax</p>	<p>PORTOS ART. AP16 ↓mm. 80 ART. AP17 ↓mm. 180 ART. AP30 ↓mm. 30 ART. AP55 ↓mm. 55 ART. AP85 Pax</p>
<p>MELROSE ART. AM16 ↓mm. 80 ART. AM17 ↓mm. 180 ART. AM30 ↓mm. 30 ART. AM55 ↓mm. 55 ART. AM85 Pax</p>	<p>SARDINIA ART. AD16 ↓mm. 80 ART. AD17 ↓mm. 180 ART. AD30 ↓mm. 30 ART. AD55 ↓mm. 55 ART. AD85 Pax</p>	<p>QUIN ART. AQ16 ↓mm. 80 ART. AQ17 ↓mm. 180 ART. AQ30 ↓mm. 30 ART. AQ55 ↓mm. 55 ART. AQ85 Pax</p>
<p>TRAVERTINO ART. AJ16 ↓mm. 80 ART. AJ17 ↓mm. 180 ART. AJ30 ↓mm. 30 ART. AJ55 ↓mm. 55 ART. AJ85 Pax</p>	<p>ROSA DEL PORTOGALLO ART. AY16 ↓mm. 80 ART. AY17 ↓mm. 180 ART. AY30 ↓mm. 30 ART. AY55 ↓mm. 55 ART. AY85 Pax</p>	<p>VERDE GUATEMALA ART. AVG16 ↓mm. 80 ART. AVG17 ↓mm. 180 ART. AVG30 ↓mm. 30 ART. AVG55 ↓mm. 55 ART. AVG85 Pax</p>
<p>JAMAICA ART. AJA16 ↓mm. 80 ART. AJA17 ↓mm. 180 ART. AJA30 ↓mm. 30 ART. AJA55 ↓mm. 55 ART. AJA85 Pax</p>	<p>ONICE ART. ANI16 ↓mm. 80 ART. ANI17 ↓mm. 180 ART. ANI30 ↓mm. 30 ART. ANI55 ↓mm. 55 ART. ANI85 Pax</p>	<p>AZZURRO ART. AZU16 ↓mm. 80 ART. AZU17 ↓mm. 180 ART. AZU30 ↓mm. 30 ART. AZU55 ↓mm. 55 ART. AZU85 Pax</p>
<p>CAYMAN ART. ACY16 ↓mm. 80 ART. ACY17 ↓mm. 180 ART. ACY30 ↓mm. 30 ART. ACY55 ↓mm. 55 ART. ACY85 Pax</p>	<p>ROSA BELLISSIMO ART. ARB16 ↓mm. 80 ART. ARB17 ↓mm. 180 ART. ARB30 ↓mm. 30 ART. ARB55 ↓mm. 55 ART. ARB85 Pax</p>	<p>ROSA ART. ARS16 ↓mm. 80 ART. ARS17 ↓mm. 180 ART. ARS30 ↓mm. 30 ART. ARS55 ↓mm. 55 ART. ARS85 Pax</p>
<p>CALIZIA ART. ACL16 ↓mm. 80 ART. ACL17 ↓mm. 180 ART. ACL30 ↓mm. 30 ART. ACL55 ↓mm. 55 ART. ACL85 Pax</p>	<p>VERONA ART. AV16 ↓mm. 80 ART. AV17 ↓mm. 180 ART. AV30 ↓mm. 30 ART. AV55 ↓mm. 55 ART. AV85 Pax</p>	<p>BRONZO METALLIZZATO ART. ABM16 ↓mm. 80 ART. ABM17 ↓mm. 180 ART. ABM30 ↓mm. 30 ART. ABM55 ↓mm. 55 ART. ABM85 Pax</p>
<p>SIERRA ART. AS16 ↓mm. 80 ART. AS17 ↓mm. 180 ART. AS30 ↓mm. 30 ART. AS55 ↓mm. 55 ART. AS85 Pax</p>	<p>ROSA PORRINO ART. ARP16 ↓mm. 80 ART. ARP17 ↓mm. 180 ART. ARP30 ↓mm. 30 ART. ARP55 ↓mm. 55 ART. ARP85 Pax</p>	<p>PUNTEGGIATURA COLOR ART. M968 Punto ↓mm. 30 ART. M968 Trattino ↓mm. 30 ART. M968 Virgola ↓mm. 30 ART. M968 Accento ↓mm. 30</p>

La superficie di adesione deve essere perfettamente piana e levigata, marmo granito vetro cristallo ecc..

- 1** Pulire accuratamente la lastra con alcool.
- 2** Tracciare a matita la linea di posizionamento del carattere. Pulire accuratamente le lettere che debbono essere perfettamente asciutte e sgrassate con alcool.
- 3** Stendere uno o due millimetri di spessore di resina siliconica neutra su tutta la superficie.
- 4** Posizionare il carattere tenendo presente che, un perfetto allineamento si ottiene facendo collimare la traccia a matita con gli incastri della lettera.
- 5** Premere leggermente. A silicone asciutto eliminare le bave con un cutter o un piccolo scalpello affilato.

ARCADIA MAXI bianco e nero

Vezzani

PORCELLANA BIANCA

ART. 5916 Lettere Minuscole	↓ cm. 8
ART. 5917 Lettere Maiuscole	↓ cm. 18
ART. 5920 Punto bianco	↓ cm. 8

PORCELLANA NERA

ART. 5918 Lettere Minuscole	↓ cm. 8
ART. 5919 Lettere Maiuscole	↓ mm. 18
ART. 5921 Punto nero	↓ cm. 8



Pipa Slava porcellana grande
ART. 5990 bianca
ART. 5990N bianca



Pipa Slava porcellana piccola
ART. 5998 bianca
ART. 5998N bianca

ART. 5634 Lettere/Numeri/Stella/Croce	c/perno ↓ mm. 30
ART. 5644 Lettere/Numeri/Stella/Croce	c/perno ↓ mm. 40
ART. 5654 Lettere/Numeri/Stella/Croce	c/perno ↓ mm. 50
ART. 5634 Punto/Virgola/Accento	c/perno x ↓ mm. 30-40-50
ART. 5634 Trattino	c/perno x ↓ mm. 30-40-50



<p>CREMA ART. ECR34 ↓ mm. 30 ART. ECR44 ↓ mm. 40 ART. ECR54 ↓ mm. 50</p>	<p>BRONZO ART. EBZ34 ↓ mm. 30 ART. EBZ44 ↓ mm. 40 ART. EBZ54 ↓ mm. 50</p>	<p>SAHARA ART. EH34 ↓ mm. 30 ART. EH44 ↓ mm. 40 ART. EH54 ↓ mm. 50</p>
<p>RIGEL ART. ERI34 ↓ mm. 30 ART. ERI44 ↓ mm. 40 ART. ERI54 ↓ mm. 50</p>	<p>TRANI ART. ETR34 ↓ mm. 30 ART. ETR44 ↓ mm. 40 ART. ETR54 ↓ mm. 50</p>	<p>CARRARA ART. EC34 ↓ mm. 30 ART. EC44 ↓ mm. 40 ART. EC54 ↓ mm. 50</p>
<p>APUANIA ART. EU34 ↓ mm. 30 ART. EU44 ↓ mm. 40 ART. EU54 ↓ mm. 50</p>	<p>TURKEY ART. ETU34 ↓ mm. 30 ART. ETU44 ↓ mm. 40 ART. ETU54 ↓ mm. 50</p>	<p>ROMA ART. ER34 ↓ mm. 30 ART. ER44 ↓ mm. 40 ART. ER54 ↓ mm. 50</p>
<p>LABRADOR ART. EZ34 ↓ mm. 30 ART. EZ44 ↓ mm. 40 ART. EZ54 ↓ mm. 50</p>	<p>BETHEL WHITE ART. EW34 ↓ mm. 30 ART. EW44 ↓ mm. 40 ART. EW54 ↓ mm. 50</p>	<p>SAHARA YELLOW ART. ESY34 ↓ mm. 30 ART. ESY44 ↓ mm. 40 ART. ESY54 ↓ mm. 50</p>
<p>SARDINIA BETA ART. ET34 ↓ mm. 30 ART. ET44 ↓ mm. 40 ART. ET54 ↓ mm. 50</p>	<p>ASPEN ART. EA34 ↓ mm. 30 ART. EA44 ↓ mm. 40 ART. EA54 ↓ mm. 50</p>	<p>PINK ART. EK34 ↓ mm. 30 ART. EK44 ↓ mm. 40 ART. EK54 ↓ mm. 50</p>
<p>VERDE ART. EE34 ↓ mm. 30 ART. EE44 ↓ mm. 40 ART. EE54 ↓ mm. 50</p>	<p>BLU ART. EB34 ↓ mm. 30 ART. EB44 ↓ mm. 40 ART. EB54 ↓ mm. 50</p>	<p>AFRICA ART. EF34 ↓ mm. 30 ART. EF44 ↓ mm. 40 ART. EF54 ↓ mm. 50</p>

<p>ALPI ART. EL34 ↓ mm. 30 ART. EL44 ↓ mm. 40 ART. EL54 ↓ mm. 50</p>	<p>RED ART. EG34 ↓ mm. 30 ART. EG44 ↓ mm. 40 ART. EG54 ↓ mm. 50</p>	<p>PORTOS ART. EP34 ↓ mm. 30 ART. EP44 ↓ mm. 40 ART. EP54 ↓ mm. 50</p>
<p>MELROSE ART. EM34 ↓ mm. 30 ART. EM44 ↓ mm. 40 ART. EM54 ↓ mm. 50</p>	<p>SARDINIA ART. ED34 ↓ mm. 30 ART. ED44 ↓ mm. 40 ART. ED54 ↓ mm. 50</p>	<p>QUIN ART. EQ34 ↓ mm. 30 ART. EQ44 ↓ mm. 40 ART. EQ54 ↓ mm. 50</p>
<p>TRAVERTINO ART. EJ34 ↓ mm. 30 ART. EJ44 ↓ mm. 40 ART. EJ54 ↓ mm. 50</p>	<p>ROSA DEL PORTOGALLO ART. EY34 ↓ mm. 30 ART. EY44 ↓ mm. 40 ART. EY54 ↓ mm. 50</p>	<p>VERDE GUATEMALA ART. EVG34 ↓ mm. 30 ART. EVG44 ↓ mm. 40 ART. EVG54 ↓ mm. 50</p>
<p>JAMAICA ART. EJA34 ↓ mm. 30 ART. EJA44 ↓ mm. 40 ART. EJA54 ↓ mm. 50</p>	<p>ONICE ART. ENI34 ↓ mm. 30 ART. ENI44 ↓ mm. 40 ART. ENI54 ↓ mm. 50</p>	<p>AZZURRO ART. EZU34 ↓ mm. 30 ART. EZU44 ↓ mm. 40 ART. EZU54 ↓ mm. 50</p>
<p>CAYMAN ART. ECY34 ↓ mm. 30 ART. ECY44 ↓ mm. 40 ART. ECY54 ↓ mm. 50</p>	<p>ROSA BELLISSIMO ART. ERB34 ↓ mm. 30 ART. ERB44 ↓ mm. 40 ART. ERB54 ↓ mm. 50</p>	<p>ROSA ART. ERS34 ↓ mm. 30 ART. ERS44 ↓ mm. 40 ART. ERS54 ↓ mm. 50</p>
<p>CALIZIA ART. ECL34 ↓ mm. 30 ART. ECL44 ↓ mm. 40 ART. ECL54 ↓ mm. 50</p>	<p>VERONA ART. EV34 ↓ mm. 30 ART. EV44 ↓ mm. 40 ART. EV54 ↓ mm. 50</p>	<p>BRONZO METALLIZZATO ART. EBM34 ↓ mm. 30 ART. EBM44 ↓ mm. 40 ART. EBM54 ↓ mm. 50</p>
<p>SIERRA ART. ES34 ↓ mm. 30 ART. ES44 ↓ mm. 40 ART. ES54 ↓ mm. 50</p>	<p>ROSA PORRINO ART. ERP34 ↓ mm. 30 ART. ERP44 ↓ mm. 40 ART. ERP54 ↓ mm. 50</p>	<p>PUNTEGGIATURA COLOR ART. M968. Punto ↓ mm. 30 ART. M968- Trattino ↓ mm. 30 ART. M968, Virgola ↓ mm. 30 ART. M968' Accento ↓ mm. 30</p>

PUNTEGGIATURA COLOR		
ART. M968.	Punto	↓ mm. 30-40-50
ART. M968-	Trattino	↓ mm. 30-40-50
ART. M968,	Virgola	↓ mm. 30-40-50
ART. M968'	Accento	↓ mm. 30-40-50

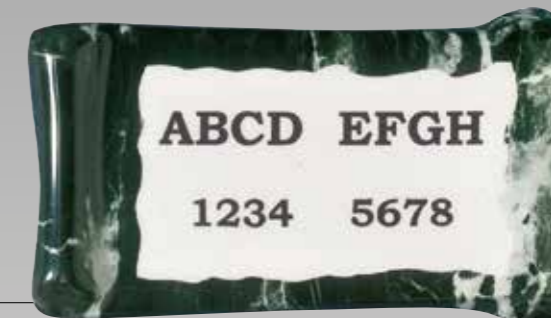

BIANCO e NERO
ART. 25100 4x16 cm.

COLORI
ART. 25300 4x16 cm.

BIANCO e NERO
ART. 25101 5x10 cm.
ART. 25102 9x15 cm.
ART. 25367 10x14 cm.
ART. 25103 11x20 cm.
ART. 25104 15x30 cm.
ART. 25105 20x40 cm.

COLORI
ART. 25301 5x10 cm.
ART. 25302 9x15 cm.
ART. 25368 10x14 cm.
ART. 25303 11x20 cm.
ART. 25304 15x30 cm.
ART. 25305 20x40 cm.



BIANCO e NERO
ART. 25222 5x10 cm.
ART. 25223 9x15 cm.
ART. 25224 11x20 cm.
ART. 25225 13x25 cm.
ART. 25226 15x30 cm.
ART. 25227 18x35 cm.
ART. 25228 20x40 cm.

COLORI
ART. 25322 5x10 cm.
ART. 25323 9x15 cm.
ART. 25324 11x20 cm.
ART. 25325 13x25 cm.
ART. 25326 15x30 cm.
ART. 25327 18x35 cm.
ART. 25328 20x40 cm.



Esempio di pergamena:
Sfondo a scelta + scritta e dedica



BIANCO e NERO
ART. 25249 11x15 cm.
ART. 25250 14x20 cm.
ART. 25251 18x25 cm.
ART. 25252 22x30 cm.
ART. 25253 29x40 cm.

COLORI
ART. 25349 11x15 cm.
ART. 25350 14x20 cm.
ART. 25351 18x25 cm.
ART. 25352 22x30 cm.
ART. 25353 29x40 cm.

BIANCO e NERO
ART. 25254 10x16 cm.
ART. 25255 12x21 cm.
ART. 25256 15x26 cm.
ART. 25257 17x31 cm.
ART. 25258 20x36 cm.
ART. 25259 22x41 cm.

COLORI
ART. 25354 10x16 cm.
ART. 25355 12x21 cm.
ART. 25356 15x26 cm.
ART. 25357 17x31 cm.
ART. 25358 20x36 cm.
ART. 25359 22x41 cm.

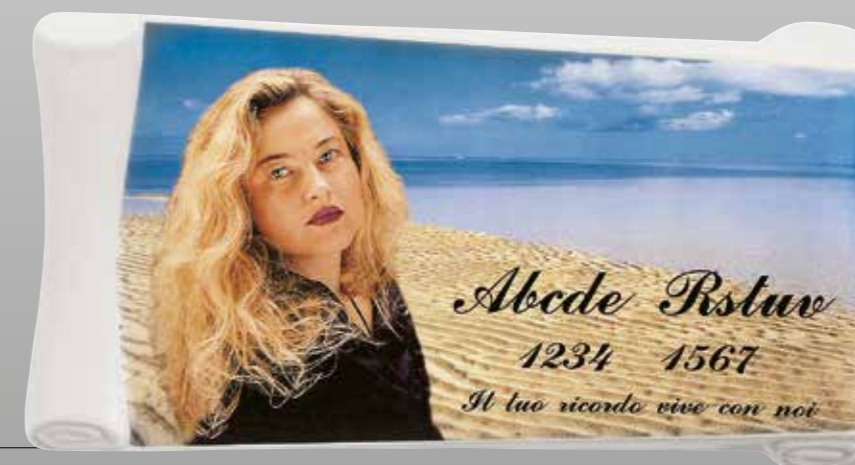

Esempio di pergamena:
Sfondo a scelta + foto scontornata + scritta e dedica

I prezzi di questi articoli sono comprensivi di tutte le varianti
(Testi e/o Foto e/o Fondo e/o Colorazioni Marmi e Graniti)



↑37 ↔50 cm. Ø 5 - R/C **P**
ART. 29906 B/N
ART. 29907 Colori



↑37 ↔50 cm. Ø 5 - R/C **P**
ART. 29910 B/N
ART. 29911 Colori



↑ 37 ↔ 50 cm. Ø 5 - R/C **P**
ART. 29908 B/N
ART. 29909 Colori



↑ 32 ↔ 53 cm. Ø 5 - R/C **P**
ART. 29912 B/N
ART. 29913 Colori

Foto a titolo d'esempio

I prezzi di questi articoli sono comprensivi di tutte le varianti:
 Testo e/o Foto e/o Fondo.

Foto a titolo d'esempio

I prezzi di questi articoli sono comprensivi di tutte le varianti:
 Testo e/o Foto e/o Fondo.







†32 ↔53 cm. Ø 5 - R/C 
 ART. 29914 B/N
 ART. 29915 Colori 



Foto a titolo d'esempio per colorazioni marmi e graniti



†32 ↔53 cm. Ø 5 - R/C 
 ART. 29916 B/N
 ART. 29917 Colori 



I prezzi di questi articoli sono comprensivi di tutte le varianti:
 Testo e/o Foto e/o Fondo.

Foto a titolo
 d'esempio



LIBRO COLORI

- P** ART. 29660 ↓ 15 ↔ 17 cm.
- ART. 29661 ↓ 21 ↔ 24 cm.
- ART. 29662 ↓ 25 ↔ 28 cm.
- ART. 29663 ↓ 30 ↔ 36 cm.
- ART. 29664 ↓ 38 ↔ 43 cm.

- T** ART. 29665 ↓ 15 ↔ 17 cm.
- ART. 29666 ↓ 21 ↔ 24 cm.
- ART. 29667 ↓ 25 ↔ 28 cm.
- ART. 29668 ↓ 30 ↔ 36 cm.
- ART. 29669 ↓ 38 ↔ 43 cm.

LIBRO BIANCO / NERO

- P** ART. 29654 ↓ 15 ↔ 17 cm.
- ART. 29658 ↓ 21 ↔ 24 cm.
- ART. 29655 ↓ 25 ↔ 28 cm.
- ART. 29656 ↓ 30 ↔ 36 cm.
- ART. 29657 ↓ 38 ↔ 43 cm.

- T** ART. 29650 ↓ 15 ↔ 17 cm.
- ART. 29659 ↓ 21 ↔ 24 cm.
- ART. 29651 ↓ 25 ↔ 28 cm.
- ART. 29652 ↓ 30 ↔ 36 cm.
- ART. 29653 ↓ 38 ↔ 43 cm.

I prezzi di questi articoli sono comprensivi di tutte le varianti:
Testo e/o Foto e/o Fondo.



Fondo 15



Fondo 16



Fondo 17



Fondo 18



Fondo 19



Fondo 20



Fondo 21



Fondo 22



Fondo 23



Fondo 24



Fondo 25



Fondo 26



Fondo 27



Fondo B



Fondo O

La Vezzani Spa in collaborazione con i maestri creatori delle porcellane di CAPODIMONTE (Napoli) presenta la collezione:

Fiori per sempre!!!



Fondo G



Fondo P



Fondo I



Fondo Q



Fondo L

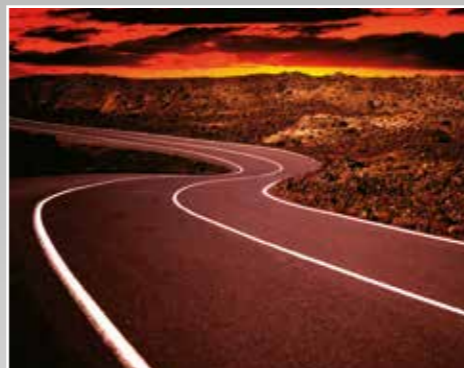

Fondo R



Fondo S



Fondo V



Fondo X



Fondo Z



Fondo T



Fondo K



Fondo U



Fondo W

Gli oggetti prodotti, con finitura a coperta lucida, sono interamente foggiate e decorati a mano da maestri del porcellanato seguendo le antiche tecniche artistiche e tradizionali. Per tutti i manufatti di tale lavorazione vedi attestazione di inalterabilità riportata a pag. 500.

Visto la sua produzione interamente fatta a mano che presenta incavità e sottosquadri, si consiglia di posizionare questo tipo di prodotto all'interno in quanto in presenza di gelo si potrebbe danneggiare.

Vezzani Spa in collaboration with the master porcelain artists of CAPODIMONTE (Naples) present their collection

Flowers for ever!!!

All of the objects, which have a glazed finish, are entirely modelled and decorated by hand by master porcelain artists, using traditional artistic techniques. All handmade articles of this type have a certificate of inalterability, shown on page 500. All these entirely handmade objects feature hollows and undercuts, and it is therefore advisable to keep this type of product indoors, as excessively cold weather could damage it.



ROSE
ART. 25400
‡ 29,5 ↔ 22,5 cm.

COMPOSIZIONE
ART. 25401
‡ 29,5 ↔ 22,5 cm.

ORCHIDEA
ART. 25402
‡ 29,5 ↔ 22,5 cm.

Floral composition in porcelain for 20 cm vases
Blumenarrangements aus porzellan für blumenvasen mit 20 cm grösse
Compositions florales en porcelaine pour jardinières de 20 cm
Arreglos florales de porcelana para floreros de 20 cm



ORCHIDEA
ART. 25405
‡ 29 ↔ 24,5 cm.

ROSE
ART. 25403
‡ 29 ↔ 24,5 cm.

COMPOSIZIONE
ART. 25404
‡ 29 ↔ 24,5 cm.

Floral composition in porcelain for 20 cm vases London series
Blumenarrangements aus porzellan für blumenvasen mit 20 cm grösse serie London
Compositions florales en porcelaine pour jardinières de 20 cm série London
Arreglos florales de porcelana para floreros de 20 cm serie London

COMPOSIZIONE
ART. 25407
↑ 38 ↔ 29 cm.
€ 755,99



ROSE
ART. 25406
↑ 38 ↔ 29 cm.
€ 755,99

Floral composition in porcelain for tubs
Blumenarrangements aus porzellan für schalen
Compositions florales en porcelaine pour baquets
Arreglos florales de porcelana para pequeños recipientes

ORCHIDEA
ART. 25408
↑ 38 ↔ 29 cm.
€ 755,99

floral composition in porcelain for small vases - blumenarrangements aus porzellan für kleine vasen
compositions florales en porcelaine pour ossuaires - arreglos florales de porcelana para osarios



COMPOSIZIONE
ART. 25410
↑ 14 ↔ 10,5 cm.

COMPOSIZIONE
ART. 25411
↑ 14 ↔ 10,5 cm.

PER OSSARI
Questa composizione si può adattare negli ossari aventi come interno plastica
ART. 73670

This composition can be used for small vases with a plastic interior.
ART. 73670

ROSE
ART. 25409
↑ 14 ↔ 10,5 cm.

PER OSSARI
Serie LONDON

Composizioni floreali in porcellana per ossario serie London.

Floral composition in porcelain for small vase London series.



ROSE
ART. 25412
↑ 13,5 ↔ 10,5 cm.

COMPOSIZIONE
ART. 25414
↑ 13,5 ↔ 10,5 cm.

COMPOSIZIONE
ART. 25413
↑ 13,5 ↔ 10,5 cm.

PORTAORCHIDEA

Composizioni floreali in porcellana per PORTAORCHIDEA

Floral composition in porcelain for orchid vase.



ROSE
ART. 25415
↑ 12 ↔ 10,5 cm.

CALLE
ART. 25416
↑ 12 ↔ 10,5 cm.

COMPOSIZIONE
ART. 25417
↑ 12 ↔ 10,5 cm.

examples of decorations on vases and tubs

beispiele für die verwendung mit vasen und schalen

exemples d'applications sur jardinières et baquets

ejemplos de aplicaciones



Examples of decorations on small vases and orchid vases

Beispiele für die verwendung mit kleinen vasen und orchideenvasen

Exemples d'applications sur ossuaires et vases à orchidées

Ejemplos de aplicaciones en osarios y porta-orquidea





ROSE
ART. 25418
↑ 13 ↔ 8,5 cm.

MARGHERITE
ART. 25420
↑ 14 ↔ 9 cm.

ORCHIDEE
ART. 25422
↑ 13,5 ↔ 9 cm.



ROSE
ART. 25419
↑ 21,5 ↔ 12 cm.

MARGHERITE
ART. 25421
↑ 22 ↔ 13 cm.

ORCHIDEE
ART. 25423
↑ 21,5 ↔ 13 cm.



ROSE
ART. 25424
↑ 23 ↔ 58 cm.



ROSE
ART. 25425
↑ 21,5 ↔ 52 cm.



ROSE
ART. 25426
↑ 24 ↔ 44 cm.



ROSE
ART. 25427
↑ 17 ↔ 48,5 cm.



COMPOSIZIONE
ART. 25428
↑ 22 ↔ 46 cm.



COMPOSIZIONE
ART. 25429
↑ 23,5 ↔ 52 cm.



COMPOSIZIONE
ART. 25432
↑ cm. 37 ↔ cm. 23



COMPOSIZIONE
ART. 25433
↑ cm. 34 ↔ cm. 22



COMPOSIZIONE
ART. 25434
↑ cm. 33,5 ↔ cm. 22



COMPOSIZIONE
ART. 25435
↑ cm. 33 ↔ cm. 22



COMPOSIZIONE
ART. 25430
↑ cm. 16 ↔ cm. 46



COMPOSIZIONE
ART. 25431
↑ cm. 17 ↔ cm. 45,5

Marmo





ART. YC7545 P
↓ 20 ↔ 12 cm.



ART. YC7045 P
↓ 20 ↔ 12 cm.



ART. YB7545 P
↓ 20 ↔ 12 cm.



ART. YB7045 P
↓ 20 ↔ 12 cm.



ART. YC9545 P
↓ 20 ↔ 18 cm.



ART. YC9045 P
↓ 20 ↔ 18 cm.



ART. YC7549 P
↓ 13 ↔ 8 cm.



ART. YC7049 P
↓ 13 ↔ 8 cm.



ART. YB7549 P
↓ 13 ↔ 8 cm.



ART. YB7049 P
↓ 13 ↔ 8 cm.



ART. YB9545 P
↓ 20 ↔ 18 cm.



ART. YB9045 P
↓ 20 ↔ 18 cm.



ART. YC6545 Ø 5
↓ 20 ↔ 10,5 cm.



ART. YC6549 Ø 4
↓ 16 ↔ 8,5 cm.



ART. YC0106 9x12 cm.
ART. YC0107 11x15 cm.
ART. YC0108 13x18 cm.



ART. YC0158 9x12 cm.
ART. YC0160 11x15 cm.
ART. YC0161 13x18 cm.



ART. YC4114
↓ 20



ART. YB6545 Ø 5
↓ 20 ↔ 10,5 cm.



ART. YB6549 Ø 4
↓ 16 ↔ 8,5 cm.



ART. YB0106 9x12 cm.
ART. YB0107 11x15 cm.
ART. YB0108 13x18 cm.

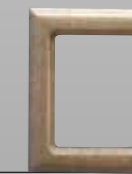

ART. YB0158 9x12 cm.
ART. YB0160 11x15 cm.
ART. YB0161 13x18 cm.



ART. YB4114
↓ 20

ART. YC6045 Ø 5
↓ 20 ↔ 10,5 cm.

ART. YC6049 Ø 4
↓ 16 ↔ 8,5 cm.

ART. YB6045 Ø 5
↓ 20 ↔ 10,5 cm.

ART. YB6049 Ø 4
↓ 16 ↔ 8,5 cm.



ART. YC7543 P $\updownarrow 20 \leftrightarrow 12$ cm. **P**
ART. YC7043 P $\updownarrow 20 \leftrightarrow 12$ cm. **T**

ART. YB7543 P $\updownarrow 20 \leftrightarrow 12$ cm. **P**
ART. YB7043 P $\updownarrow 20 \leftrightarrow 12$ cm. **T**

ART. YC9543 P $\updownarrow 19 \leftrightarrow 18$ cm. **P**
ART. YC9043 P $\updownarrow 19 \leftrightarrow 18$ cm. **T**

ART. YC7547 P $\updownarrow 13,5 \leftrightarrow 8,5$ cm. **P**
ART. YC7047 P $\updownarrow 13,5 \leftrightarrow 8,5$ cm. **T**

ART. YB7547 P $\updownarrow 13,5 \leftrightarrow 8,5$ cm. **P**
ART. YB7047 P $\updownarrow 13,5 \leftrightarrow 8,5$ cm. **T**

ART. YB9543 P $\updownarrow 19 \leftrightarrow 18$ cm. **P**
ART. YB9043 P $\updownarrow 19 \leftrightarrow 18$ cm. **T**

ART. YC6543 $\varnothing 5$ $\updownarrow 19 \leftrightarrow 10$ cm. **P**

ART. YC6547 $\varnothing 4$ $\updownarrow 14,5 \leftrightarrow 8,5$ cm. **P**

ART. YC0106 9x12 cm.
ART. YC0107 11x15 cm.
ART. YC0108 13x18 cm.

ART. YC0158 9x12 cm.
ART. YC0160 11x15 cm.
ART. YC0161 13x18 cm.

ART. YC4114
 $\updownarrow 20$

ART. YB6543 $\varnothing 5$ $\updownarrow 19 \leftrightarrow 10$ cm. **P**

ART. YB6547 $\varnothing 4$ $\updownarrow 14,5 \leftrightarrow 8,5$ cm. **P**

ART. YB0106 9x12 cm.
ART. YB0107 11x15 cm.
ART. YB0108 13x18 cm.

ART. YB0158 9x12 cm.
ART. YB0160 11x15 cm.
ART. YB0161 13x18 cm.

ART. YB4114
 $\updownarrow 20$

ART. YC6043 $\varnothing 5$ $\updownarrow 19 \leftrightarrow 10$ cm. **T**

ART. YC6047 $\varnothing 4$ $\updownarrow 14,5 \leftrightarrow 8,5$ cm. **T**

ART. YB6043 $\varnothing 5$ $\updownarrow 19 \leftrightarrow 10$ cm. **T**

ART. YB6047 $\varnothing 4$ $\updownarrow 14,5 \leftrightarrow 8,5$ cm. **T**



ART. YC7532 P P
↓ 20,5 ↔ 12 cm.

ART. YC7024 P T
↓ 20,5 ↔ 12 cm.

ART. YC7533 R
↓ 20,5 ↔ 12 cm.

ART. YC7027 R
↓ 20,5 ↔ 12 cm.

ART. YB7532 P P
↓ 20,5 ↔ 12 cm.

ART. YB7024 P T
↓ 20,5 ↔ 12 cm.

ART. YB7533 R
↓ 20,5 ↔ 12 cm.

ART. YB7027 R
↓ 20,5 ↔ 12 cm.



ART. YC9015 P P T
↓ 20 ↔ 18,5 cm.



ART. YC9017 P P
↓ 20,5 ↔ 20 cm.



ART. YC6532 Ø 5 P
↓ 21 ↔ 10,5 cm.



ART. YB6532 Ø 5 P
↓ 21 ↔ 10,5 cm.



ART. YB9017 P P
↓ 20,5 ↔ 20 cm.



ART. YB9015 P P T
↓ 20 ↔ 18,5 cm.

ART. YC9016 R
↓ 20 ↔ 18,5 cm.

ART. YC9018
INT ALLUMINIO
↓ 20,5 ↔ 20 cm.

ART. YC6032 Ø 5 T
↓ 21 ↔ 10,5 cm.

ART. YB6032 Ø 5 T
↓ 21 ↔ 10,5 cm.

ART. YB9018
INT ALLUMINIO
↓ 20,5 ↔ 20 cm.

ART. YB9016 R
↓ 20 ↔ 18,5 cm.



ART. YC7513 P P
↓ 13,5 ↔ 8 cm.

ART. YC7013 P T
↓ 13,5 ↔ 8 cm.

ART. YC7514 R
↓ 13,5 ↔ 8 cm.

ART. YC7014 R
↓ 13,5 ↔ 8 cm.



ART. YC6513 Ø 4 P
↓ 14 ↔ 8 cm.

ART. YC6013 Ø 4 T
↓ 14 ↔ 8 cm.



ART. YC0106 9x12 cm.
ART. YC0107 11x15 cm.
ART. YC0108 13x18 cm.



ART. YC0158 9x12 cm.
ART. YC0160 11x15 cm.
ART. YC0161 13x18 cm.



ART. YC4114
↓ 20



ART. YB7513 P P
↓ 13,5 ↔ 8 cm.

ART. YB7514 R
↓ 13,5 ↔ 8 cm.

ART. YB7013 P T
↓ 13,5 ↔ 8 cm.

ART. YB7014 R
↓ 13,5 ↔ 8 cm.



ART. YB6513 Ø 4 P
↓ 14 ↔ 8 cm.

ART. YB6013 Ø 4 T
↓ 14 ↔ 8 cm.



ART. YB0106 9x12 cm.
ART. YB0107 11x15 cm.
ART. YB0108 13x18 cm.



ART. YB0158 9x12 cm.
ART. YB0160 11x15 cm.
ART. YB0161 13x18 cm.



ART. YB4114
↓ 20



ART. YC7530 P
↓ 20 ↔ 13 cm.



ART. YC7030 P
↓ 20 ↔ 13 cm.



ART. YB7530 P
↓ 20 ↔ 13 cm.

ART. YB7030 P
↓ 20 ↔ 13 cm.

ART. YC7531 R
↓ 20 ↔ 13 cm.

ART. YC7031 R
↓ 20 ↔ 13 cm.

ART. YB7531 R
↓ 20 ↔ 13 cm.

ART. YB7031 R
↓ 20 ↔ 13 cm.



ART. YC9026 P
↓ 20 ↔ 19 cm.

ART. YC9027 R
↓ 20 ↔ 19 cm.



ART. YC9012 P
↓ 21 ↔ 20,5 cm.

ART. YC9013
INT ALLUMINIO
↓ 21 ↔ 20,5 cm.



ART. YB9012 P
↓ 21 ↔ 20,5 cm.

ART. YB9013
INT ALLUMINIO
↓ 21 ↔ 20,5 cm.



ART. YB9026 P
↓ 20 ↔ 19 cm.

ART. YB9027 R
↓ 20 ↔ 19 cm.



ART. YC6530 Ø 5
↓ 21 ↔ 10 cm.

ART. YC6030 Ø 5
↓ 21 ↔ 10 cm.



ART. YC0158 9x12 cm.
ART. YC0160 11x15 cm.
ART. YC0161 13x18 cm.



ART. YC0106 9x12 cm.
ART. YC0107 11x15 cm.
ART. YC0108 13x18 cm.



ART. YC4114
↓ 20



ART. YB6530 Ø 5
↓ 21 ↔ 10 cm.

ART. YB6030 Ø 5
↓ 21 ↔ 10 cm.



ART. YB0158 9x12 cm.
ART. YB0160 11x15 cm.
ART. YB0161 13x18 cm.



ART. YB0106 9x12 cm.
ART. YB0107 11x15 cm.
ART. YB0108 13x18 cm.



ART. YB4114
↓ 20



ART. YC7535 P **P**
↓ 20,5 ↔ 12,5 cm.

ART. YC7035 P **T**
↓ 20,5 ↔ 12,5 cm.

ART. YC7536 R
↓ 20,5 ↔ 12,5 cm.

ART. YC7036 R
↓ 20,5 ↔ 12,5 cm.

ART. YB7535 P **P**
↓ 20,5 ↔ 12,5 cm.

ART. YB7035 P **T**
↓ 20,5 ↔ 12,5 cm.

ART. YB7536 R
↓ 20,5 ↔ 12,5 cm.

ART. YB7036 R
↓ 20,5 ↔ 12,5 cm.



ART. YC9028 P **P** **T**
↓ 20,5 ↔ 19 cm.

ART. YC9029 R
↓ 20,5 ↔ 19 cm.



ART. YB9028 P **P** **T**
↓ 20,5 ↔ 19 cm.

ART. YB9029 R
↓ 20,5 ↔ 19 cm.



ART. YC6535 Ø 5 **P**
↓ 20,5 ↔ 10,5 cm.

ART. YC6035 Ø 5 **T**
↓ 20,5 ↔ 10,5 cm.



ART. YC0106 9x12 cm.
ART. YC0107 11x15 cm.
ART. YC0108 13x18 cm.



ART. YC0158 9x12 cm.
ART. YC0160 11x15 cm.
ART. YC0161 13x18 cm.



ART. YC4114
↓ 20



ART. YB6535 Ø 5 **P**
↓ 20,5 ↔ 10,5 cm.

ART. YB6035 Ø 5 **T**
↓ 20,5 ↔ 10,5 cm.



ART. YB0106 9x12 cm.
ART. YB0107 11x15 cm.
ART. YB0108 13x18 cm.



ART. YB0158 9x12 cm.
ART. YB0160 11x15 cm.
ART. YB0161 13x18 cm.



ART. YB4114
↓ 20



ART. YC7537 P P
↓ 20 ↔ 12,5 cm.

ART. YC7037 P T
↓ 20 ↔ 12,5 cm.

ART. YC7538 R
↓ 20,5 ↔ 12,5 cm.

ART. YC7038 R
↓ 20 ↔ 12,5 cm.

ART. YB7537 P P
↓ 20 ↔ 12,5 cm.

ART. YB7037 P T
↓ 20 ↔ 12,5 cm.

ART. YB7538 R
↓ 20,5 ↔ 12,5 cm.

ART. YB7038 R
↓ 20 ↔ 12,5 cm.



ART. YC9030 P P T
↓ 20 ↔ 19,5 cm.

ART. YC9031 R
↓ 20 ↔ 19,5 cm.

ART. YB9030 P P T
↓ 20 ↔ 19,5 cm.

ART. YB9031 R
↓ 20 ↔ 19,5 cm.



ART. YC6537 Ø 5
↓ 20,5 ↔ 10 cm.

ART. YC6037 Ø 5
↓ 20,5 ↔ 10 cm.



ART. YC0106 9x12 cm.
ART. YC0107 11x15 cm.
ART. YC0108 13x18 cm.



ART. YC0158 9x12 cm.
ART. YC0160 11x15 cm.
ART. YC0161 13x18 cm.



ART. YC4114
↓ 20



ART. YB6537 Ø 5
↓ 20,5 ↔ 10 cm.

ART. YB6037 Ø 5
↓ 20,5 ↔ 10 cm.



ART. YB0106 9x12 cm.
ART. YB0107 11x15 cm.
ART. YB0108 13x18 cm.



ART. YB0158 9x12 cm.
ART. YB0160 11x15 cm.
ART. YB0161 13x18 cm.



ART. YB4114
↓ 20



ART. YC7540 P **P**
↓ 20,5 ↔ 12,5 cm.

ART. YC7040 P **T**
↓ 20,5 ↔ 12,5 cm.

ART. YB7540 P **P**
↓ 20,5 ↔ 12,5 cm.

ART. YB7040 P **T**
↓ 20,5 ↔ 12,5 cm.

ART. YC7541 R
↓ 20,5 ↔ 12,5 cm.

ART. YC7041 R
↓ 20,5 ↔ 12,5 cm.

ART. YB7541 R
↓ 20,5 ↔ 12,5 cm.

ART. YB7041 R
↓ 20,5 ↔ 12,5 cm.



ART. YC9032 P **P T**
↓ 20 ↔ 19,5 cm.

ART. YC9033 R
↓ 20 ↔ 19,5 cm.



ART. YB9032 P **P T**
↓ 20 ↔ 19,5 cm.

ART. YB9033 R
↓ 20 ↔ 19,5 cm.



ART. YC6540 Ø 5 **P**
↓ 20,5 ↔ 10 cm.

ART. YC6040 Ø 5 **T**
↓ 20,5 ↔ 10 cm.



ART. YC0106 9x12 cm.
ART. YC0107 11x15 cm.
ART. YC0108 13x18 cm.



ART. YC0158 9x12 cm.
ART. YC0160 11x15 cm.
ART. YC0161 13x18 cm.



ART. YC4114
↓ 20



ART. YB6540 Ø 5 **P**
↓ 20,5 ↔ 10 cm.

ART. YB6040 Ø 5 **T**
↓ 20,5 ↔ 10 cm.



ART. YB0106 9x12 cm.
ART. YB0107 11x15 cm.
ART. YB0108 13x18 cm.



ART. YB0158 9x12 cm.
ART. YB0160 11x15 cm.
ART. YB0161 13x18 cm.



ART. YB4114
↓ 20



ART. YC7525 P **P** ↓ 20 ↔ 14 cm.
ART. YC7025 P **T** ↓ 20 ↔ 14 cm.
ART. YC7526 R ↓ 20 ↔ 14 cm.
ART. YC7026 R ↓ 20 ↔ 14 cm.

ART. YB7525 P **P** ↓ 20 ↔ 14 cm.
ART. YB7025 P **T** ↓ 20 ↔ 14 cm.
ART. YB7526 R ↓ 20 ↔ 14 cm.
ART. YB7026 R ↓ 20 ↔ 14 cm.

ART. YC9005 P **P T** ↓ 19 ↔ 19 cm.
ART. YC9006 R ↓ 19 ↔ 19 cm.

ART. YC9007 P **P** ↓ 20 ↔ 20 cm.
ART. YC9008 R ↓ 19 ↔ 19 cm.

ART. YC6525 Ø 5 **P** ↓ 10 ↔ 10 cm.
ART. YC6025 Ø 5 **T** ↓ 10 ↔ 10 cm.

ART. YB6525 Ø 5 **P** ↓ 10 ↔ 10 cm.
ART. YB6025 Ø 5 **T** ↓ 10 ↔ 10 cm.

ART. YB9007 P **P** ↓ 20 ↔ 20 cm.
ART. YB9008 R ↓ 19 ↔ 19 cm.

ART. YB9005 P **P T** ↓ 19 ↔ 19 cm.
ART. YB9006 R ↓ 19 ↔ 19 cm.

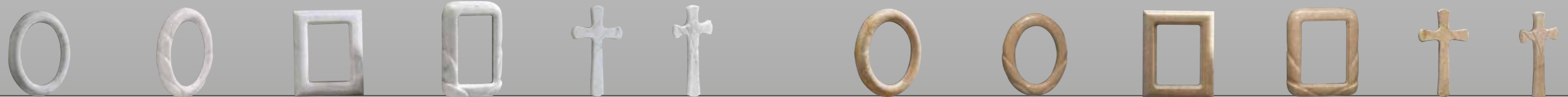

ART. YC0106 9x12 cm. ART. YC0109 9x12 cm. ART. YC0158 9x12 cm. ART. YC0162 9x12 cm. ART. YC4114 ↓ 20 ART. YC4115 ↓ 20
ART. YC0107 11x15 cm. ART. YC0110 11x15 cm. ART. YC0160 11x15 cm. ART. YC0164 11x15 cm.
ART. YC0108 13x18 cm. ART. YC0111 13x18 cm. ART. YC0161 13x18 cm. ART. YC0165 13x18 cm.

ART. YB0106 9x12 cm. ART. YB0109 9x12 cm. ART. YB0158 9x12 cm. ART. YB0162 9x12 cm. ART. YB4114 ↓ 20 ART. YB4115 ↓ 20
ART. YB0107 11x15 cm. ART. YB0110 11x15 cm. ART. YB0160 11x15 cm. ART. YB0164 11x15 cm.
ART. YB0108 13x18 cm. ART. YB0111 13x18 cm. ART. YB0161 13x18 cm. ART. YB0165 13x18 cm.

Itaca



ART. YC7520 P ↓ 21 ↔ 13 cm. **P**
 ART. YC7020 P ↓ 21 ↔ 13 cm. **T**
 ART. YC6520 Ø 5 ↓ 10 ↔ 11 cm. **P**
 ART. YC7521 R ↓ 21 ↔ 13 cm. **P**
 ART. YC7021 R ↓ 21 ↔ 13 cm. **T**
 ART. YC6020 Ø 5 ↓ 10 ↔ 11 cm. **T**

Classica



ART. YC9001 P ↓ 20 ↔ 20 cm. **P**
 ART. YC6000 Ø 5 ↓ 10 ↔ 16 cm. **P**
 ART. YC9009 R ↓ 20 ↔ 20 cm. **P**

Itaca



ART. YB7520 P ↓ 21 ↔ 13 cm. **P**
 ART. YB7020 P ↓ 21 ↔ 13 cm. **T**
 ART. YB6520 Ø 5 ↓ 10 ↔ 11 cm. **P**
 ART. YB7521 R ↓ 21 ↔ 13 cm. **P**
 ART. YB7021 R ↓ 21 ↔ 13 cm. **T**
 ART. YB6020 Ø 5 ↓ 10 ↔ 11 cm. **T**

Classica



ART. YB9001 P ↓ 20 ↔ 20 cm. **P**
 ART. YB6000 Ø 5 ↓ 10 ↔ 16 cm. **P**
 ART. YB9009 R ↓ 20 ↔ 20 cm. **P**

Taormina



ART. YC9002 P ↓ 18,5 ↔ 18,5 cm. **P**
 ART. YC6002 Ø 5 ↓ 10,5 ↔ 16 cm. **P**
 ART. YC9010 R ↓ 18,5 ↔ 18,5 cm. **P**

Odeon



ART. YC9004 P ↓ 20 ↔ 19 cm. **P**
 ART. YC6004 Ø 5 ↓ 11 ↔ 14,5 cm. **P**
 ART. YC9011 R ↓ 20 ↔ 19 cm. **P**

Taormina



ART. YB9002 P ↓ 18,5 ↔ 18,5 cm. **P**
 ART. YB6002 Ø 5 ↓ 10,5 ↔ 16 cm. **P**
 ART. YB9010 R ↓ 18,5 ↔ 18,5 cm. **P**

Odeon



ART. YB9004 P ↓ 20 ↔ 19 cm. **P**
 ART. YB6004 Ø 5 ↓ 11 ↔ 14,5 cm. **P**
 ART. YB9011 R ↓ 20 ↔ 19 cm. **P**



ART. YC0106 9x12 cm.
 ART. YC0107 11x15 cm.
 ART. YC0108 13x18 cm.



ART. YC0158 9x12 cm.
 ART. YC0160 11x15 cm.
 ART. YC0161 13x18 cm.



ART. YC4114
 ↓ 20



ART. YB0106 9x12 cm.
 ART. YB0107 11x15 cm.
 ART. YB0108 13x18 cm.



ART. YB0158 9x12 cm.
 ART. YB0160 11x15 cm.
 ART. YB0161 13x18 cm.



ART. YB4114
 ↓ 20



ART. YC7015 P **T**
 ↓ 13,5 ↔ 8 cm.

ART. YC7016 R
 ↓ 13,5 ↔ 8 cm.



ART. YC7515 P **P**
 ↓ 13,5 ↔ 8 cm.

ART. YC7516 R
 ↓ 13,5 ↔ 8 cm.



ART. YC6515 Ø 4 **P**
 ↓ 15,5 ↔ 7,5 cm.

ART. YC6015 Ø 4 **T**
 ↓ 15,5 ↔ 7,5 cm.



ART. YB7015 P **T**
 ↓ 13,5 ↔ 8 cm.

ART. YB7016 R
 ↓ 13,5 ↔ 8 cm.



ART. YB7515 P **P**
 ↓ 13,5 ↔ 8 cm.

ART. YB7516 R
 ↓ 13,5 ↔ 8 cm.



ART. YB6515 Ø 4 **P**
 ↓ 15,5 ↔ 7,5 cm.

ART. YB6015 Ø 4 **T**
 ↓ 15,5 ↔ 7,5 cm.



ART. YC7081 P **T**
 ↓ 8 ↔ 19,5 cm.

ART. YC7082 |
 ↓ 8 ↔ 19,5 cm.



ART. YC6081 Ø 5 **T**
 ↓ 8 ↔ 11,5 cm.



ART. YC6083 Ø 5 **T**
 ↓ 5,5 ↔ 11,5 cm.



ART. YC7083 P **T**
 ↓ 8 ↔ 19 cm.

ART. YC7084 |
 ↓ 8 ↔ 19 cm.

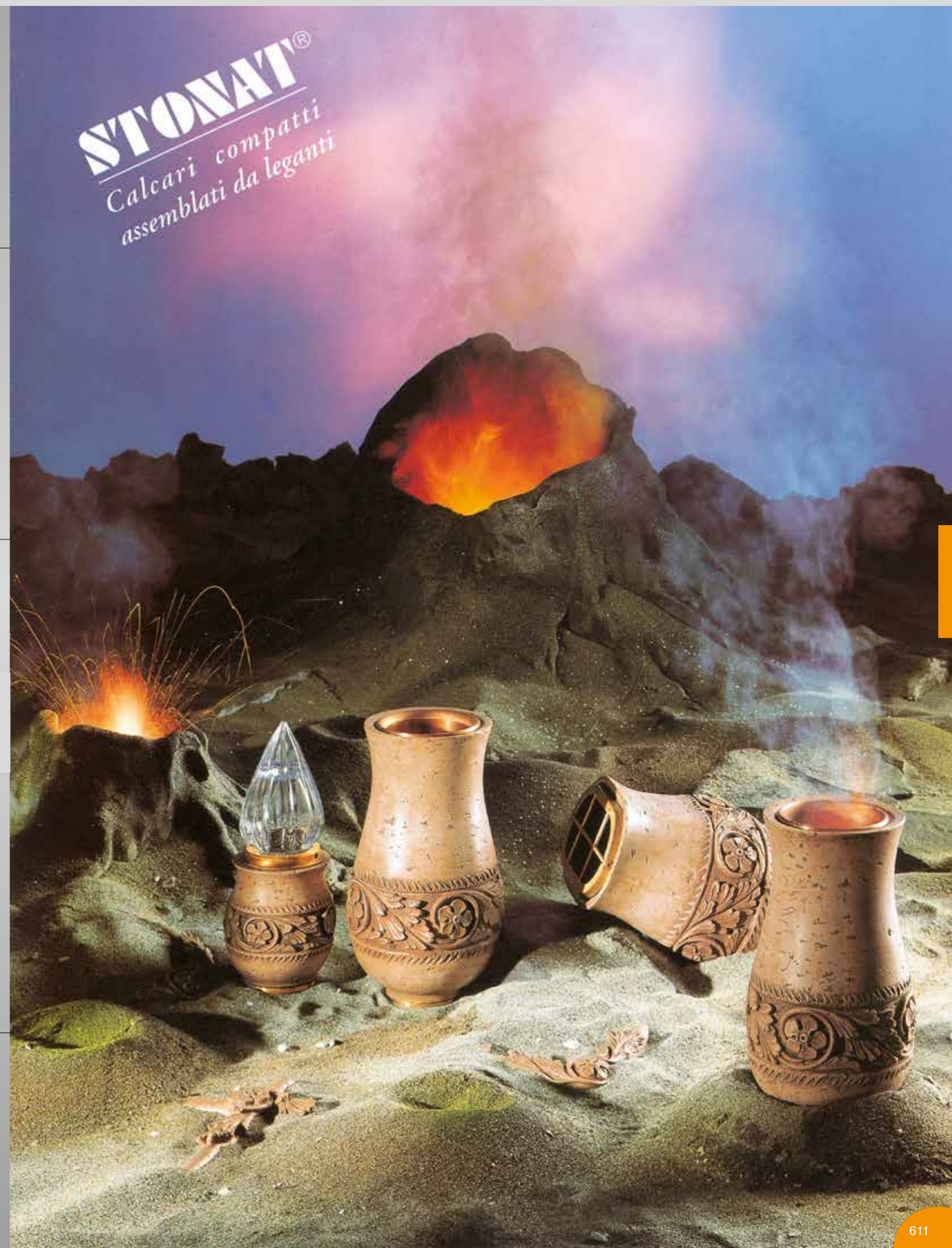



ART. 0042 R T
↓ 28 ↔ 16,5 cm.

ART. 0041 P T
↓ 28 ↔ 16,5 cm.



ART. 0079 R T
↓ 20 ↔ 11 cm.

ART. 0078 P T
↓ 20 ↔ 11 cm.



ART. 0233 R T
↓ 18 ↔ 16 cm.

ART. 0232 P T
↓ 18 ↔ 16 cm.

ART. 0275 R P
↓ 18 ↔ 16 cm.

ART. 0274 P P
↓ 18 ↔ 16 cm.



ART. 0044 R T
↓ 28 ↔ 16,5 cm.

ART. 0043 P T
↓ 28 ↔ 16,5 cm.



ART. 0099 R T
↓ 20 ↔ 11 cm.

ART. 0098 P T
↓ 20 ↔ 11 cm.



ART. 0235 R T
↓ 18 ↔ 16 cm.

ART. 0234 P T
↓ 18 ↔ 16 cm.

ART. 0277 R P
↓ 18 ↔ 16 cm.

ART. 0276 P P
↓ 18 ↔ 16 cm.



ART. 0122 Ø 6 T
↓ 26 ↔ 12 cm.



ART. 0123 Ø 5 T
↓ 20 ↔ 8,5 cm.



ART. 0184 Ø 5 P
↓ 20 ↔ 8,5 cm.

ART. 0124 Ø 6 T
↓ 26 ↔ 12 cm.



ART. 0125 Ø 5 T
↓ 20 ↔ 8,5 cm.

ART. 0185 Ø 5 P
↓ 20 ↔ 8,5 cm.



ART. 0506 9x12 cm.

ART. 0507 11x15 cm.

ART. 0508 13x18 cm.



ART. 0554 9x12 cm.

ART. 0555 10x15 cm.

ART. 0556 11x15 cm.

ART. 0557 13x18 cm.



T INOX
ART. 0014 R
↓ 29 ↔ 18 cm.
ART. 0015 P
↓ 29 ↔ 18 cm.



T PR. LEGA BRONZO
ART. 0012 R
↓ 29 ↔ 18 cm.
ART. 0013 P
↓ 29 ↔ 18 cm.



T **ART. 0022 P**
↓ 26 ↔ 16 cm.



T INOX
ART. 0011 R
↓ 21 ↔ 13 cm.
ART. 0018 P
↓ 21 ↔ 13 cm.

PR. LEGA BRONZO
ART. 0010 R
↓ 21 ↔ 13 cm.
ART. 0019 P
↓ 21 ↔ 13 cm.

T INOX
ART. 0025 R/C
↓ 19 ↔ 10 cm.
ART. 0026 P
↓ 19 ↔ 10 cm.

PR. LEGA BRONZO
ART. 0023 R
↓ 19 ↔ 10 cm.
ART. 0024 P
↓ 19 ↔ 10 cm.



T INOX
ART. 0029 R/C
↓ 14 ↔ 8 cm.
ART. 0030 P
↓ 14 ↔ 8 cm.



PR. LEGA BRONZO
ART. 0027 R
↓ 14 ↔ 8 cm.
ART. 0028 P
↓ 14 ↔ 8 cm.



T INOX
ART. 0036 P
↓ 11 ↔ 6 cm.
PR. LEGA BRONZO
ART. 0031 P
↓ 11 ↔ 6 cm.

T INOX
ART. 0211 R/C
↓ 18 ↔ 17 cm.
ART. 0213 P
↓ 18 ↔ 17 cm.

PR. LEGA BRONZO
ART. 0210 R
↓ 18 ↔ 17 cm.
ART. 0212 P
↓ 18 ↔ 17 cm.



T **ART. 46709**
↓ 27 ↔ 15 cm.



T INOX
ART. 0113 Ø 6
↓ 26 ↔ 14 cm.
PR. LEGA BRONZO
ART. 0112 Ø 6
↓ 26 ↔ 14 cm.



T INOX
ART. 0111 Ø 5
↓ 20 ↔ 9 cm.
PR. LEGA BRONZO
ART. 0110 Ø 5
↓ 20 ↔ 9 cm.



T INOX
ART. 0115 Ø 4
↓ 14 ↔ 7 cm.
PR. LEGA BRONZO
ART. 0114 Ø 4
↓ 14 ↔ 7 cm.



T **ART. 46707**
↓ 18 ↔ 13 cm.
ART. 46708
↓ 22 ↔ 17 cm.



ART. 0504 6x8 cm.
ART. 0505 7x9 cm.
ART. 0502 8x10 cm.
ART. 0500 9x12 cm.
ART. 0501 11x15 cm.
ART. 0503 13x18 cm.



ART. 0550 9x12 cm.
ART. 0552 10x15 cm.
ART. 0551 11x15 cm.
ART. 0553 13x18 cm.



ART. 0400 ↓ 15 ↔ 9 cm.
ART. 0401 ↓ 20 ↔ 11 cm.
ART. 0402 ↓ 30 ↔ 14 cm.
ART. 0403 ↓ 40 ↔ 15 cm.



P INOX
ART. 0051 R
↓ 21 ↔ 13 cm.

PR. LEGA BRONZO
ART. 0050 R
↓ 21 ↔ 13 cm.

ART. 0016 P
↓ 21 ↔ 13 cm.

ART. 0017 P
↓ 21 ↔ 13 cm.



P INOX
ART. 0053 R/C
↓ 19 ↔ 10 cm.

PR. LEGA BRONZO
ART. 0052 R
↓ 19 ↔ 10 cm.

ART. 0021 P
↓ 19 ↔ 10 cm.

ART. 0020 P
↓ 19 ↔ 10 cm.



P INOX
ART. 0056 R/C
↓ 14 ↔ 8 cm.

PR. LEGA BRONZO
ART. 0054 R
↓ 14 ↔ 8 cm.

ART. 0057 P
↓ 14 ↔ 8 cm.

ART. 0055 P
↓ 14 ↔ 8 cm.



P INOX
ART. 0063 P
↓ 11 ↔ 6 cm.

PR. LEGA BRONZO
ART. 0058 P
↓ 11 ↔ 6 cm.



P INOX
ART. 0251 R/C
↓ 18 ↔ 17 cm.

PR. LEGA BRONZO
ART. 0250 R
↓ 18 ↔ 17 cm.

ART. 0253 P
↓ 18 ↔ 17 cm.

ART. 0252 P
↓ 18 ↔ 17 cm.



P INOX
ART. 0258 P
↓ 17 ↔ 17,5 cm.

PR. LEGA BRONZO
ART. 0259 P
↓ 17 ↔ 17,5 cm.



P **ART. 46909 P**
↓ 18 ↔ 13 cm.



P INOX
ART. 0151 Ø 5
↓ 20 ↔ 9 cm.

PR. LEGA BRONZO
ART. 0150 Ø 5
↓ 20 ↔ 9 cm.



P INOX
ART. 0153 Ø 4
↓ 14 ↔ 7 cm.

PR. LEGA BRONZO
ART. 0152 Ø 4
↓ 14 ↔ 7 cm.



P INOX
ART. 0158 Ø 5
↓ 20 ↔ 13 cm.

PR. LEGA BRONZO
ART. 0159 Ø 5
↓ 20 ↔ 13 cm.



ART. 0504 6x8 cm.
ART. 0505 7x9 cm.
ART. 0502 8x10 cm.
ART. 0500 9x12 cm.
ART. 0501 11x15 cm.
ART. 0503 13x18 cm.



ART. 0550 9x12 cm.
ART. 0552 10x15 cm.
ART. 0551 11x15 cm.
ART. 0553 13x18 cm.



ART. 0400 ↓ 15 ↔ 9 cm.
ART. 0401 ↓ 20 ↔ 11 cm.
ART. 0402 ↓ 30 ↔ 14 cm.
ART. 0403 ↓ 40 ↔ 15 cm.



PR. LEGA BRONZO

- ART. 0059 R P ↓ 20 ↔ 13 cm.
- ART. 0060 P ↓ 20 ↔ 13 cm.
- ART. 0032 R T ↓ 20 ↔ 13 cm.
- ART. 0033 P ↓ 20 ↔ 13 cm.
- ART. 0037 R ↓ 28 ↔ 18 cm.
- ART. 0038 P ↓ 28 ↔ 18 cm.



PR. LEGA BRONZO

- ART. 0154 Ø 5 P ↓ 21 ↔ 10 cm.
- ART. 0116 Ø 5 T ↓ 21 ↔ 10 cm.
- ART. 0118 Ø 6 ↓ 26 ↔ 14 cm.



PR. LEGA BRONZO

- ART. 0254 R P ↓ 17 ↔ 17 cm.
- ART. 0255 P ↓ 17 ↔ 17 cm.
- ART. 0214 R T ↓ 17 ↔ 17 cm.
- ART. 0215 P ↓ 17 ↔ 17 cm.



INOX

- ART. 0061 R P ↓ 20 ↔ 13 cm.
- ART. 0062 P ↓ 20 ↔ 13 cm.
- ART. 0034 R T ↓ 20 ↔ 13 cm.
- ART. 0035 P ↓ 20 ↔ 13 cm.
- ART. 0039 R ↓ 28 ↔ 18 cm.
- ART. 0040 P ↓ 28 ↔ 18 cm.



INOX

- ART. 0155 Ø 5 P ↓ 21 ↔ 10 cm.
- ART. 0117 Ø 5 T ↓ 21 ↔ 10 cm.
- ART. 0119 Ø 6 ↓ 26 ↔ 14 cm.



INOX

- ART. 0256 R/C P ↓ 17 ↔ 17 cm.
- ART. 0257 P ↓ 17 ↔ 17 cm.
- ART. 0216 R/C T ↓ 17 ↔ 17 cm.
- ART. 0217 P ↓ 17 ↔ 17 cm.



- ART. 0510 9x12 cm.
- ART. 0511 11x15 cm.



- ART. 0560 9x12 cm.
- ART. 0561 10x15 cm.
- ART. 0562 11x15 cm.



PR. LEGA BRONZO

ART. 0047 R T
↓ 28 ↔ 18 cm.

ART. 0048 P
↓ 28 ↔ 18 cm.

INOX

ART. 0045 R T
↓ 28 ↔ 18 cm.

ART. 0046 P
↓ 28 ↔ 18 cm.



PR. LEGA BRONZO

ART. 0064 R P
↓ 20 ↔ 13 cm.

ART. 0065 P
↓ 20 ↔ 13 cm.

INOX

ART. 0066 R P
↓ 20 ↔ 13 cm.

ART. 0067 P
↓ 20 ↔ 13 cm.

ART. 0080 R T
↓ 20 ↔ 13 cm.

ART. 0081 P
↓ 20 ↔ 13 cm.

ART. 0082 R T
↓ 20 ↔ 13 cm.

ART. 0083 P
↓ 20 ↔ 13 cm.



PR. LEGA BRONZO

ART. 0068 R P
↓ 20 ↔ 13 cm.

ART. 0069 P
↓ 20 ↔ 13 cm.

INOX

ART. 0070 R P
↓ 20 ↔ 13 cm.

ART. 0071 P
↓ 20 ↔ 13 cm.

ART. 0084 R T
↓ 20 ↔ 13 cm.

ART. 0085 P
↓ 20 ↔ 13 cm.

ART. 0086 R T
↓ 20 ↔ 13 cm.

ART. 0087 P
↓ 20 ↔ 13 cm.



PR. LEGA BRONZO

ART. 0147 Ø 6 T
↓ 25 ↔ 11 cm.

INOX

ART. 0148 Ø 6 T
↓ 25 ↔ 11 cm.



PR. LEGA BRONZO

ART. 0164 Ø 5 P
↓ 19 ↔ 9 cm.

INOX

ART. 0166 Ø 5 P
↓ 19 ↔ 9 cm.

ART. 0180 Ø 5 T
↓ 19 ↔ 9 cm.

ART. 0182 Ø 5 T
↓ 19 ↔ 9 cm.



PR. LEGA BRONZO

ART. 0260 R P
↓ 19 ↔ 17 cm.

ART. 0261 P
↓ 19 ↔ 17 cm.

INOX

ART. 0262 R/C P
↓ 19 ↔ 17 cm.

ART. 0263 P
↓ 19 ↔ 17 cm.

ART. 0218 R T
↓ 19 ↔ 17 cm.

ART. 0219 P
↓ 19 ↔ 17 cm.

ART. 0220 R/C T
↓ 19 ↔ 17 cm.

ART. 0221 P
↓ 19 ↔ 17 cm.



PR. LEGA BRONZO

ART. 0264 R P
↓ 19 ↔ 17 cm.

ART. 0265 P
↓ 19 ↔ 17 cm.

INOX

ART. 0266 R/C P
↓ 19 ↔ 17 cm.

ART. 0267 P
↓ 19 ↔ 17 cm.

ART. 0222 R T
↓ 19 ↔ 17 cm.

ART. 0223 P
↓ 19 ↔ 17 cm.

ART. 0224 R/C T
↓ 19 ↔ 17 cm.

ART. 0225 P
↓ 19 ↔ 17 cm.



ART. 0512 9x12 cm.

ART. 0513 11x15 cm.

ART. 0514 13x18 cm.



ART. 0563 9x12 cm.

ART. 0564 11x15 cm.

ART. 0565 13x18 cm.



ART. 0515 9x12 cm.

ART. 0516 11x15 cm.

ART. 0517 13x18 cm.



ART. 0566 9x12 cm.

ART. 0567 11x15 cm.

ART. 0568 13x18 cm.



ART. 0404 ↓ 15 ↔ 9 cm.

ART. 0405 ↓ 20 ↔ 11 cm.



PERGAMENA PERSONALIZZABILE

ART. 0300 ↓ 5 ↔ 10 cm.
 ART. 0301 ↓ 9 ↔ 15 cm.
 ART. 0316 ↓ 11 ↔ 15 cm.
 ART. 0302 ↓ 11 ↔ 20 cm.

ART. 0303 ↓ 13 ↔ 25 cm.
 ART. 0304 ↓ 15 ↔ 30 cm.
 ART. 0305 ↓ 18 ↔ 35 cm.
 ART. 0306 ↓ 20 ↔ 40 cm.

È possibile personalizzare con i seguenti caratteri scolpiti:
 new corsivo - fantasy - futuro - romano - futuro stretto
 L'altezza minima di questi caratteri è di 6 mm.



NEW CORSIVO



FUTURO



FUTURO STRETTO



ROMANO

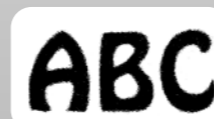

FANTASY

I testi saranno calcolati in base alla dimensione dell'articolo ed al numero di lettere che si dovranno scrivere.
 Al momento dell'ordinazione è necessario specificare il tipo di carattere scelto e se si vuole minuscolo e/o maiuscolo.



ART. 0307
 ↓ 11 ↔ 15 cm.



ART. 0308
 ↓ 11 ↔ 15 cm.



ART. 0309
 ↓ 11 ↔ 15 cm.



ART. 0310
 ↓ 11 ↔ 15 cm.



ART. 0311
 ↓ 11 ↔ 15 cm.



ART. 0312
 ↓ 11 ↔ 15 cm.



ART. 0313
 ↓ 11 ↔ 15 cm.



ART. 0314
 ↓ 11 ↔ 15 cm.



ART. 0315
 ↓ 11 ↔ 15 cm.



BUSTO PADRE PIO
ART. 0810
 ↑ 14 ↔ 9,5 cm.



BUSTO PADRE PIO
ART. 0811
 ↑ 14 ↔ 9,5 cm.



MADONNA
ART. 0355
 ↓ 13 ↔ 9,5 cm.



CRISTO
ART. 0356
 ↓ 13 ↔ 9 cm.



MADONNA
ART. 0358
 ↓ 13 ↔ 9 cm.



CRISTO
ART. 0359
 ↓ 13 ↔ 9 cm.



TRALCIO ROSE
ART. 0360
 ↓ 14 ↔ 9 cm.



TRALCIO ROSE
ART. 0361
 ↓ 24 ↔ 12 cm.



TRALCIO ROSE
ART. 0362
 ↓ 33 ↔ 12 cm.



PART. PIETÀ
ART. 0357
 ↓ 14 ↔ 15 cm.



VOLTO CRISTO
ART. 0353
 ↓ 16 ↔ 10,5 cm.



VOLTO MADONNA
ART. 0354
 ↓ 16 ↔ 10,5 cm.



PART. PIETÀ
ART. 0352
 ↓ 19 ↔ 10 cm.



MADONNA
ART. 0375
 ↓ 20,5 ↔ 15 cm.



MADONNA
ART. 0376
 ↓ 20,5 ↔ 15 cm.



ANGELO
ART. 0374
 ↓ 14,5 ↔ 12 cm.



ACQUASANTIERA
ART. 0373
 ↓ 14,5 ↔ 12 cm.



STATUA ANGELO SDRAIATO
ART. 0816
 ↓ 12 ↔ 23,5 cm.



STATUA ANGELO INGINOCCHIATO
ART. 0815
 ↓ 17 ↔ 11,5 cm.



PART. PIETÁ
ART. 0351
↑ 27 ↔ 18 cm.



CRISTO
ART. 0364
↑ 35 ↔ 26 cm.



MADONNA
ART. 0363
↑ 35 ↔ 26 cm.



PADRE PIO
ART. 0812
↑ 24 ↔ 8 cm.



PADRE PIO
ART. 0813
↑ 24 ↔ 8 cm.



MADONNA
ART. 0809
↑ 28 ↔ 24 cm.



PART. PIETÁ
ART. 0350
↑ 35,5 ↔ 20 cm.



PART. PIETÁ
ART. 0365
↑ 43 ↔ 39 cm.



PADRE PIO
ART. 0814
↑ 38 ↔ 12 cm.



PADRE PIO
ART. 0806
↑ 52 ↔ 20 cm.



PADRE PIO
ART. 0808
↑ 57 ↔ 23 cm.



ART. 0602
 ↓ 28 ↔ 24 cm.
 con apertura alla base
 capacità di 2200 cm³



ART. 0603
 ↓ 28 ↔ 24 cm.
 con apertura alla base
 capacità di 2200 cm³



ART. 0820
 ↓ 57 ↔ 23 cm.



ART. 0823
 ↓ 65 ↔ 22 cm.



ART. 0822
 ↓ 68 ↔ 26 cm.

Per la loro particolare lavorazione questi prodotti sono consigliati solo per ambienti interni.
 Because of their particular finishing, these products are recommended only for inside.
 Wegen seiner besonderer Feinarbeit werden diese Produkte nur für Innenseite empfehlen.
 Por su especial elaboración, estos productos se destinan sólo a su montaje en interior.
 Compte tenu de leur facture particulière, ces articles sont conseillés uniquement pour les espaces internes.

Per la loro particolare lavorazione questi prodotti sono consigliati solo per ambienti interni.
 Because of their particular finishing, these products are recommended only for inside.
 Wegen seiner besonderer Feinarbeit werden diese Produkte nur für Innenseite empfehlen.
 Por su especial elaboración, estos productos se destinan sólo a su montaje en interior.
 Compte tenu de leur facture particulière, ces articles sont conseillés uniquement pour les espaces internes.

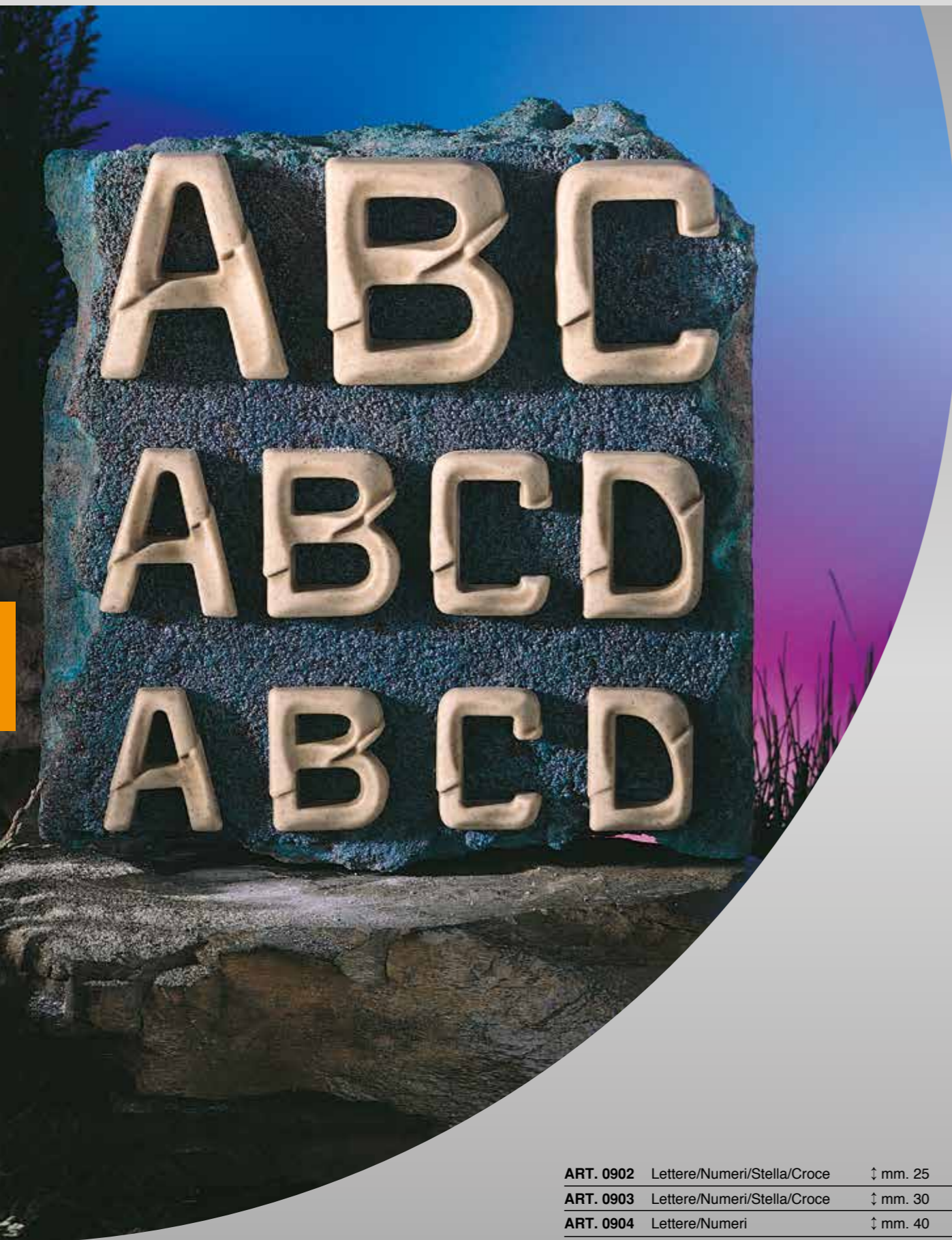

ART. 0902	Lettere/Numeri/Stella/Croce	↓ mm. 25
ART. 0903	Lettere/Numeri/Stella/Croce	↓ mm. 30
ART. 0904	Lettere/Numeri	↓ mm. 40
ART. 0905	Lettere	↓ mm. 50

ART. 0906	Lettere	↓ mm. 60
ART. 0908	Lettere	↓ mm. 80
ART. 0909	Punto/Virgola/Accento	x mm. 25-30-40-50
ART. 0909	Trattino	x mm. 25-30-40-50
ART. 0910	Punto/ Virgola	x mm. 60-80

ART. 1100 I
 ↓ 21 ↔ 12 cm.

ART. 1150 I
 ↓ 21 ↔ 12 cm.

ART. 1110 I
 ↓ 21 ↔ 12 cm.

ART. 1160 I
 ↓ 21 ↔ 12 cm.

ART. 1910 R/C
 ↓ 19 ↔ 16 cm.

ART. 1960 R/C
 ↓ 19 ↔ 16 cm.

ART. 1900 R/C
 ↓ 19 ↔ 16 cm.

ART. 1950 R/C
 ↓ 19 ↔ 16 cm.

ART. 1200 Ø 5
 ↓ 19 ↔ 9 cm.

ART. 1250 Ø 5
 ↓ 19 ↔ 9 cm.

ART. 1210 Ø 5
 ↓ 19 ↔ 9 cm.

ART. 1260 Ø 5
 ↓ 19 ↔ 9 cm.

ART. 5826 LETTERE/NUMERI ↓ 25 mm

ART. 5831 LETTERE/NUMERI ↓ 30 mm

ART. 5841 LETTERE ↓ 40 mm

ART. 5851 LETTERE ↓ 50 mm

ART. 11601 7x9 cm.

ART. 11602 8x10 cm.

ART. 11603 9x12 cm.

ART. 11604 11x15 cm.

ART. 11610 7x9 cm.

ART. 11611 8x10 cm.

ART. 11612 9x12 cm.

ART. 11613 10x15 cm.

ART. 11614 11x15 cm.

ART. 12410 ↓ 10 ↔ 4 cm.

ART. 12412 ↓ 12 ↔ 5 cm.

ART. 12415 ↓ 15 ↔ 5 cm.

ART. 12420 ↓ 20 ↔ 6 cm.

ART. 5725 LETTERE/NUMERI ↓ 25 mm.

ART. 5735 LETTERE/NUMERI ↓ 35 mm.

ART. 5745 LETTERE/NUMERI ↓ 45 mm.

ART. 5760 LETTERE/NUMERI ↓ 60 mm.

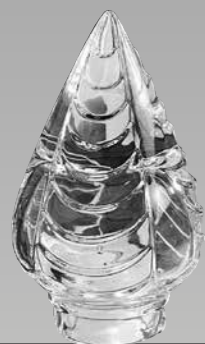

fiamma cristallo vieste
ART. 85065 Ø 5



fiamma cristallo
ART. 85028 Ø 5
↑ 12 cm.



fiamma cristallo tuscanly
ART. 85070 Ø 5



fiamma cristallo
ART. 85062 Ø 5



fiamma cristallo
ART. 85073 Ø 5
ART. 85069 Ø 4



fiamma cristallo
ART. 85074 Ø 5
ART. 85064 Ø 4



fiamma cristallo
ART. 85027 Ø 5
↑ 12 cm.



fiamma cristallo
ART. 85026 Ø 5
↑ 12 cm.



fiamma cristallo
ART. 85061 Ø 5



fiamma cristallo
ART. 85071 Ø 5
ART. 85067 Ø 4



fiamma cristallo
ART. 85072 Ø 5
ART. 85063 Ø 4



fiamma cristallo colore ambra
ART. 85072A Ø 5



fiamma cristallo colore blu
ART. 85072B Ø 5



fiamma cristallo colore rosso
ART. 85072R Ø 5



fiamma cristallo
ART. 85087 Ø 5



fiamma cristallo
ART. 85082 Ø 5



fiamma cristallo
ART. 85088 Ø 5



fiamma cristallo
ART. 85083 Ø 5



fiamma venezia (vetro)
ART. 85054 Ø 4
ART. 85055 Ø 5
ART. 85076 Ø 6



fiamma vetro
ART. 85049 Ø 5
ART. 85034 Ø 4



fiamma cristallo
ART. 85079 Ø 5



fiamma cristallo
ART. 85077 Ø 5
ART. 85036 Ø 4



fiamma cristallo
ART. 85052 Ø 5
ART. 85037 Ø 4

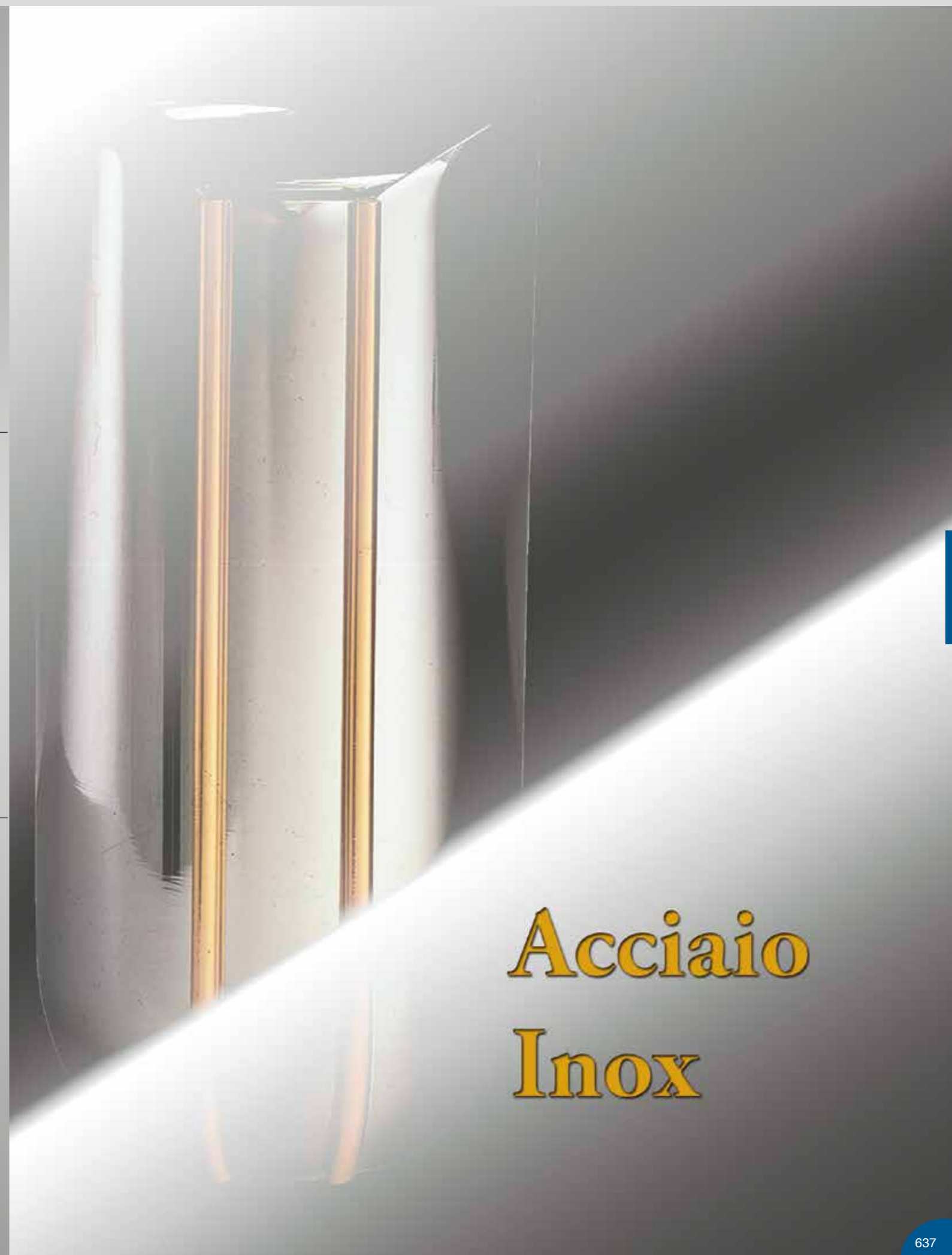

Acciaio
Inox



ART. 17136 | T
↑ 25 ↔ 15 cm.



ART. 17535 | P **ART. 17135 | T**
↑ 19 ↔ 13 cm. ↑ 19 ↔ 13 cm.



ART. 16136 Ø 6 | T
↑ 24 ↔ 12 cm.



ART. 16535 Ø 5 | P
↑ 18 ↔ 9 cm.



ART. 17137 | T
↑ 5 ↔ 19 cm.

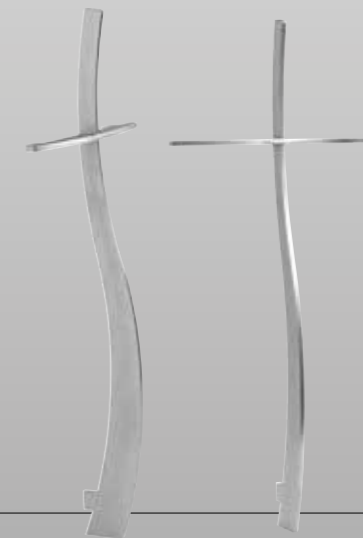

ART. 14311 | P
↑ 20 ↔ 9 cm.
ART. 14312
↑ 30 ↔ 13 cm.
ART. 14313
↑ 40 ↔ 17,5 cm.



ART. 17671 | **P**
↑ 19 ↔ 9 cm.



ART. 17171 | **T**
↑ 19 ↔ 9 cm.

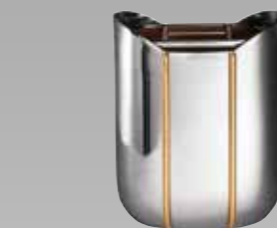

ART. 19671 R | **P**
↑ 17 ↔ 14 cm.



ART. 19171 R | **T**
↑ 17 ↔ 14 cm.



ART. 16671 Ø 5 | **P**
↑ 19 ↔ 9 cm.

ART. 16271 Ø 5 | **T**
↑ 19 ↔ 9 cm.



ART. 11607
9x12 cm.



ART. 11621
9x12 cm.

SERIE RAFFAELLO ORO



ART. 17672 | **P**
↑ 21 ↔ 14 cm.



ART. 17172 | **T**
↑ 21 ↔ 14 cm.



ART. 19672 R | **P**
↑ 17 ↔ 14 cm.



ART. 19172 R | **T**
↑ 17 ↔ 14 cm.



ART. 16672 Ø 5 | **P**
↑ 19 ↔ 10 cm.

ART. 16272 Ø 5 | **T**
↑ 19 ↔ 10 cm.



ART. 14250
↑ 20 ↔ 8 cm.



ART. 14260
↑ 20 ↔ 8 cm.

ART. 14251
↑ 30 ↔ 13 cm.

ART. 14261
↑ 30 ↔ 13 cm.

SERIE REGGIO LISCIA



ART. 17670 | **P**
↑ 19 ↔ 9 cm.



ART. 17170 | **T**
↑ 19 ↔ 9 cm.



ART. 19670 R | **P**
↑ 17 ↔ 14 cm.



ART. 19170 R | **T**
↑ 17 ↔ 14 cm.



ART. 16670 Ø 5 | **P**
↑ 19 ↔ 9 cm.

ART. 16270 Ø 5 | **T**
↑ 19 ↔ 9 cm.



ART. 11605
9x12 cm.



ART. 11620
9x12 cm.

ART. 11606
11x15 cm.

ART. 11620
9x12 cm.



ART. 17022 | **T**
↓ 28 ↔ 14 cm.



ART. 17520 | **P** ART. 17020 | **T**
↓ 19 ↔ 10 cm. ↓ 19 ↔ 10 cm.



ART. 17021 | **T**
↓ 20 ↔ 10 cm.



ART. 17521 | **P**
↓ 20 ↔ 10 cm.



ART. 16121 Ø 6 | **T**
↓ 22 ↔ 10 cm.



ART. 16260 Ø 5 | **P** ART. 16120 Ø 5 | **T**
↓ 18 ↔ 8 cm. ↓ 18 ↔ 8 cm.



ART. 16122 Ø 5 | **T**
↓ 19 ↔ 8 cm.



ART. 16261 Ø 5 | **P**
↓ 19 ↔ 8 cm.



ART. 11601 7x9 cm.



ART. 11610 7x9 cm.



ART. 12408 ↓ 8 ↔ 4 cm.



ART. 14015 ↓ 15 ↔ 10 cm.

ART. 11602 8x10 cm.

ART. 11611 8x10 cm.

ART. 12410 ↓ 10 ↔ 4 cm.

ART. 14020 ↓ 20 ↔ 10 cm.

ART. 11603 9x12 cm.

ART. 11612 9x12 cm.

ART. 12412 ↓ 12 ↔ 5 cm.

ART. 14025 ↓ 25 ↔ 10 cm.

ART. 11604 11x15 cm.

ART. 11613 10x15 cm.

ART. 12415 ↓ 15 ↔ 5 cm.

ART. 14030 ↓ 30 ↔ 10 cm.

ART. 11614 11x15 cm.

ART. 12420 ↓ 20 ↔ 6 cm.

ART. 14035 ↓ 35 ↔ 10 cm.

ART. 11615 13x18 cm.

ART. 12425 ↓ 25 ↔ 7 cm.

ART. 14040 ↓ 40 ↔ 10 cm.

ART. 11616 18x24 cm.

ART. 12430 ↓ 30 ↔ 8 cm.

ART. 12435 ↓ 35 ↔ 8 cm.

ART. 12440 ↓ 40 ↔ 10 cm.



ART. 17800 | P
↓ 22 ↔ 11 cm.



ART. 17953 | P
↓ 21 ↔ 10 cm.

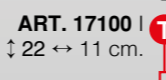

ART. 17100 | T
↓ 22 ↔ 11 cm.

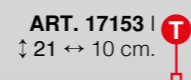

ART. 17153 | T
↓ 21 ↔ 10 cm.



ART. 16950 Ø 5 | P
↓ 19 ↔ 11 cm.



ART. 17952 | P
↓ 20 ↔ 10 cm.

ART. 16150 Ø 5 | T
↓ 20 ↔ 11 cm.

ART. 17152 | T
↓ 20 ↔ 10 cm.



ART. 16960 Ø 5 | P
↓ 19 ↔ 11 cm.



ART. 17810 | P
↓ 21 ↔ 11 cm.



ART. 16952 Ø 5 | P
↓ 18 ↔ 8 cm.



ART. 19952 | P
R/C
↓ 16 ↔ 15 cm.



ART. 16651 | P
↓ 15 ↔ 11 cm.

ART. 16160 Ø 5 | T
↓ 20 ↔ 11 cm.

ART. 17110 | T
↓ 22 ↔ 11 cm.

ART. 16152 Ø 5 | T
↓ 18 ↔ 8 cm.

ART. 19152 | T
R/C
↓ 16 ↔ 15 cm.

ART. 16451 | T
↓ 15 ↔ 11 cm.



ART. 17328 P T
↓ 41 ↔ 19 cm.



ART. 16503 T
↓ 25 ↔ 20 cm.



ART. 17710 P P
↓ 17 ↔ 12 cm.

ART. 17310 P T
↓ 19 ↔ 12 cm.



ART. 16306 P P
↓ 13 ↔ 11 cm.

ART. 16106 T
↓ 14 ↔ 11 cm.

Fiamma 11x7 cm.



ART. 17322 P T
↓ 30 ↔ 19 cm.



ART. 16110 Ø 6 T
↓ 27 ↔ 11 cm.



ART. 17701 P P
↓ 12 ↔ 8 cm.

ART. 17301 P T
↓ 13 ↔ 8 cm.



ART. 16301 Ø 4 P
↓ 15 ↔ 7 cm.

ART. 16101 Ø 4 T
↓ 17 ↔ 7 cm.



ART. 17711 P P
↓ 17 ↔ 13 cm.

ART. 17311 P T
↓ 19 ↔ 13 cm.



ART. 17724 P P
↓ 20 ↔ 12 cm.



ART. 16307 P P
↓ 13 ↔ 12 cm.

ART. 16107 T
↓ 14 ↔ 12 cm.



ART. 16312 P P
↓ 13 ↔ 11 cm.

ART. 16116 T
↓ 13 ↔ 11 cm.

ART. 17715 P P
↓ 20 ↔ 13 cm.

ART. 17315 P T
↓ 22 ↔ 13 cm.

ART. 17333 P T
↓ 22 ↔ 12 cm.

Fiamma 11x7 cm.

Fiamma 11x7 cm.



ART. 11726 9x12 cm.
ART. 11727 10x15 cm.
ART. 11728 11x15 cm.
ART. 11733 13x18 cm.

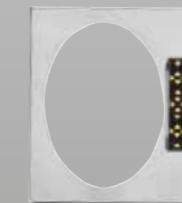

ART. 11704 9x12 cm.
ART. 11705 11x15 cm.
ART. 11707 13x18 cm.



ART. 18104 9x12 cm.
ART. 18105 11x15 cm.
ART. 18107 13x18 cm.



ART. 18126 9x12 cm.
ART. 18127 10x15 cm.
ART. 18128 11x15 cm.
ART. 18133 13x18 cm.



Plex Nero
ART. 17252 P
↑ 32 ↔ 18 cm.



Plex Nero P ART. 17642 P
↑ 20 ↔ 12 cm.

Plex Nero T ART. 17247 P
↑ 21 ↔ 12 cm.



Plex Nero P ART. 19510 P
↑ 18 ↔ 20 cm.

Plex Nero T ART. 19108 P
↑ 20 ↔ 20 cm.



Plex Nero P ART. 16244 Ø 5
↑ 17 ↔ 12 cm.

Plex Nero T ART. 16067 Ø 5
↑ 18 ↔ 12 cm.



Plex Nero T
ART. 16425
↑ 25 ↔ 20 cm.



Plex Nero P ART. 16625
↑ 16 ↔ 20 cm.

Plex Nero T ART. 16436
↑ 18 ↔ 20 cm.



ART. 17638 P
↓ 20 ↔ 12 cm.

ART. 17243 P
↓ 21 ↔ 12 cm.

ART. 17248 P
↓ 32 ↔ 18 cm.



ART. 19505 P
↓ 18 ↔ 20 cm.

ART. 19104 P
↓ 20 ↔ 20 cm.



ART. 16241 Ø 5
↓ 17 ↔ 12 cm.

ART. 16064 Ø 5
↓ 18 ↔ 12 cm.



ART. 16422 T
↓ 25 ↔ 18 cm.



ART. 16624 P
↓ 14 ↔ 11 cm.

ART. 16435 T
↓ 16 ↔ 11 cm.



ART. 17249 P
↓ 32 ↔ 18 cm.



ART. 17639 P
↓ 20 ↔ 12 cm.

ART. 17244 P
↓ 21 ↔ 12 cm.



ART. 16242 Ø 5
↓ 17 ↔ 12 cm.

ART. 16065 Ø 5
↓ 18 ↔ 12 cm.



ART. 16617 P
↓ 16 ↔ 18 cm.

ART. 16426 T
↓ 18 ↔ 18 cm.



ART. 19506 P
↓ 18 ↔ 20 cm.

ART. 19105 P
↓ 20 ↔ 20 cm.



ART. 17831 P
↓ 20 ↔ 10 cm.

ART. 17131 P
↓ 21 ↔ 10 cm.



ART. 16931 Ø 5
↓ 19 ↔ 10 cm.

ART. 16131 Ø 5
↓ 20 ↔ 10 cm.



ART. 16423 T
↓ 25 ↔ 20 cm.



ART. 16618 P
↓ 16 ↔ 20 cm.

ART. 16427 T
↓ 18 ↔ 20 cm.



ART. 17440 P
↓ 12 ↔ 5 cm.

ART. 17040 P
↓ 12 ↔ 5 cm.



ART. 17450 P
↓ 10 ↔ 3,5 cm.



ART. 17648 P
↓ 20 ↔ 8 cm.

ART. 17253 P
↓ 22 ↔ 8 cm.

ART. 17258 P
↓ 28 ↔ 11 cm.



ART. 17649 P
↓ 16 ↔ 7 cm.

ART. 17257 P
↓ 16 ↔ 7 cm.

ART. 17652 P
↓ 13 ↔ 6,5 cm.

ART. 17155 P
↓ 13 ↔ 6,5 cm.



ART. 16627 Ø 5
↓ 15 ↔ 8 cm.

ART. 16078 Ø 5
↓ 18 ↔ 8 cm.



ART. 17606 P
↓ 17 ↔ 10 cm.

ART. 17201 P
↓ 17 ↔ 10 cm.



stelo e
copertura
ART. 90910
↓ 35 ↔ 11 cm.

portafiori
terreno
ART. 90900
↓ 9 ↔ 18 cm.

Negli ordini citare il tipo di cornice desiderata. Il prezzo è composto dal portafiori più stelo e copertura, cornice scelta a parete.



ART. 17700 P
↓ 12 ↔ 8 cm.

ART. 17708 P
↓ 17 ↔ 12 cm.

ART. 17712 P
↓ 20 ↔ 12 cm.

ART. 17300 P
↓ 13 ↔ 8 cm.

ART. 17308 P
↓ 19 ↔ 12 cm.

ART. 17312 P
↓ 22 ↔ 12 cm.

ART. 17320 P
↓ 30 ↔ 19 cm.

ART. 17330 P
↓ 41 ↔ 19 cm.



ART. 16300 Ø 4
↓ 15 ↔ 7 cm.

ART. 16308 Ø 6
↓ 25 ↔ 11 cm.

ART. 16100 Ø 4
↓ 17 ↔ 7 cm.

ART. 16108 Ø 6
↓ 27 ↔ 11 cm.

ART. 16112 Ø 8
↓ 33 ↔ 18 cm.



ART. 16304 P
↓ 13 ↔ 11 cm.

ART. 16104 P
↓ 14 ↔ 11 cm.

Fiamma 11x7 cm.



ART. 17616 P
↓ 12 ↔ 7 cm.

ART. 17617 P
↓ 15 ↔ 8 cm.

ART. 17618 P
↓ 18 ↔ 11 cm.

ART. 17619 P
↓ 21 ↔ 13 cm.

ART. 17620 P
↓ 24 ↔ 15 cm.

ART. 17216 P
↓ 12 ↔ 7 cm.

ART. 17217 P
↓ 15 ↔ 8 cm.

ART. 17218 P
↓ 19 ↔ 11 cm.

ART. 17219 P
↓ 21 ↔ 13 cm.

ART. 17220 P
↓ 25 ↔ 15 cm.



ART. 16224 Ø 5
↓ 17 ↔ 20 cm.

ART. 16029 Ø 5
↓ 18 ↔ 20 cm.



ART. 16740 Ø 4
↓ 12 ↔ 5 cm.

ART. 16540 Ø 4
↓ 13 ↔ 5 cm.



ART. 16200 Ø 5
↓ 15 ↔ 8 cm.

ART. 16010 Ø 5
↓ 18 ↔ 8 cm.



ART. 17658 P
↓ 13 ↔ 6,5 cm.

ART. 17608 P
↓ 20 ↔ 8 cm.

ART. 17158 P
↓ 13 ↔ 6,5 cm.

ART. 17206 P
↓ 22 ↔ 8 cm.

ART. 17207 P
↓ 28 ↔ 11 cm.



ART. 17621 P
↓ 11 ↔ 6 cm.
ART. 17622 P
↓ 15 ↔ 7 cm.
ART. 17623 P
↓ 18 ↔ 9 cm.
ART. 17624 P
↓ 20 ↔ 10 cm.



ART. 17222 P
↓ 12 ↔ 6 cm.
ART. 17223 P
↓ 16 ↔ 7 cm.
ART. 17224 P
↓ 19 ↔ 9 cm.
ART. 17225 P
↓ 22 ↔ 10 cm.



ART. 16232 Ø 4
↓ 14 ↔ 6 cm.
ART. 16233 Ø 5
↓ 17 ↔ 7 cm.



ART. 16041 Ø 4
↓ 14 ↔ 6 cm.
ART. 16044 Ø 5
↓ 18 ↔ 7 cm.



ART. 16234 Ø 5
↓ 17 ↔ 9 cm.



ART. 16047 Ø 5
↓ 17 ↔ 9 cm.



ART. 17200 P
↓ 31 ↔ 15 cm.



ART. 16409 T
↓ 30 ↔ 12 cm.



ART. 16603 P
↓ 19 ↔ 11 cm.



ART. 16405 T
↓ 21 ↔ 11 cm.



ART. 17603 P
↓ 20 ↔ 10 cm.
ART. 17604 P
↓ 25 ↔ 13 cm.

ART. 17202 P
↓ 23 ↔ 10 cm.
ART. 17203 P
↓ 28 ↔ 13 cm.
ART. 17229 P
↓ 31 ↔ 16 cm.
ART. 17230 P
↓ 42 ↔ 21 cm.



ART. 17625 P
↓ 15 ↔ 13 cm.
ART. 17626 P
↓ 19 ↔ 14 cm.
ART. 17627 P
↓ 20 ↔ 15 cm.



ART. 17226 P
↓ 17 ↔ 13 cm.
ART. 17227 P
↓ 20 ↔ 14 cm.
ART. 17228 P
↓ 23 ↔ 15 cm.



ART. 16246 Ø 4
↓ 14 ↔ 13 cm.
ART. 16247 Ø 5
↓ 17 ↔ 14 cm.



ART. 16071 Ø 4
↓ 14 ↔ 13 cm.
ART. 16073 Ø 5
↓ 17 ↔ 14 cm.



ART. 16245 Ø 5
↓ 17 ↔ 14 cm.



ART. 16068 Ø 5
↓ 18 ↔ 14 cm.



ART. 16600 P
↓ 13 ↔ 7 cm.
ART. 16611
↓ 15 ↔ 11 cm.



ART. 16401 T
↓ 14 ↔ 7 cm.
ART. 16415
↓ 17 ↔ 11 cm.



ART. 16604 P
↓ 15 ↔ 9 cm.



ART. 16407 T
↓ 15 ↔ 9 cm.



ART. 17640 P
↓ 17,5 ↔ 8 cm.



ART. 16200 Ø 5
↓ 15 ↔ 8 cm.



ART. 17641 P
↓ 17,5 ↔ 8 cm.



ART. 16640 Ø 5
↓ 15 ↔ 8 cm.



ART. 16432 T
↓ 32 ↔ 18 cm.



ART. 16605 P
↓ 20 ↔ 12 cm.



ART. 16408 T
↓ 22 ↔ 12 cm.



ART. 10891
 Ø 12 cm.



ART. 10890
 Ø 12 cm.



ART. 17515 I
 † 4,5 Ø 19 cm.
 int. inox 70902



ART. 17510 I
 † 3 Ø 13,5 cm.
 int. inox 70910



ART. 17511 Ø 15 cm.

Portafiore Incasso in rame
 cromato con anello in acciaio
 inox 18/10

ART. 17516 P
 † 4,5 Ø 19 cm.
 int. plastica 70235

ART. 17512 P
 † 3 Ø 13,5 cm.
 int. plastica 73660 + ghiera

lampada elettrica
 da appendere



ART. 16810
 † 68 ↔ 20 cm.
 fiamma Ø 8



ART. 16516
 fiamma Ø 6
 † 3 Ø 13,5 cm.



ART. 16515
 fiamma Ø 5
 † 2,5 Ø 9 cm.



ART. 11700 9x12 cm.
ART. 11701 11x15 cm.
ART. 11706 13x18 cm.



ART. 11720 9x12 cm.
ART. 11721 10x15 cm.
ART. 11722 11x15 cm.
ART. 11719 13x18 cm.

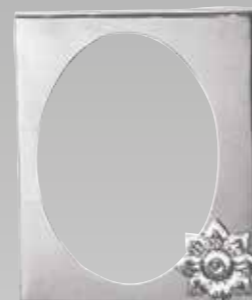

ART. 11702 9x12 cm.
ART. 11703 11x15 cm.
ART. 11740 13x18 cm.



ART. 11723 9x12 cm.
ART. 11724 10x15 cm.
ART. 11725 11x15 cm.
ART. 11741 13x18 cm.

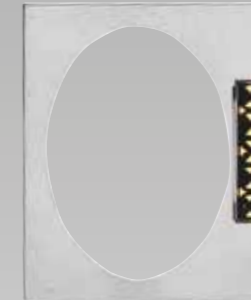

ART. 11704 9x12 cm.
ART. 11705 11x15 cm.
ART. 11707 13x18 cm.



ART. 11726 9x12 cm.
ART. 11727 10x15 cm.
ART. 11728 11x15 cm.
ART. 11733 13x18 cm.



ART. 11710 9x12 cm.
ART. 11711 11x15 cm.
ART. 11709 13x18 cm.



ART. 11730 9x12 cm.
ART. 11731 10x15 cm.
ART. 11732 11x15 cm.
ART. 11729 13x18 cm.



ART. 11736 9x12 cm.



ART. 11735 9x12 cm.



ART. 11685 9x12 cm.
ART. 11686 11x15 cm.



ART. 11660 9x12 cm.



ART. 11680 Ø 12 cm.
ART. 11681 Ø 8 cm.
ART. 11682 Ø 10 cm.

Inclinazione a richiesta su tutti i tipi cornici

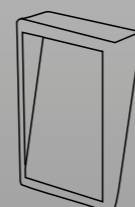

Inclinazione a richiesta su tutti i tipi cornici

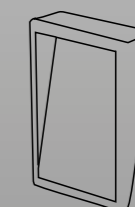



ART. 11601 7x9 cm.
ART. 11602 8x10 cm.
ART. 11603 9x12 cm.
ART. 11604 11x15 cm.

ART. 11610 7x9 cm.
ART. 11611 8x10 cm.
ART. 11612 9x12 cm.
ART. 11613 10x15 cm.
ART. 11614 11x15 cm.
ART. 11615 13x18 cm.
ART. 11616 18x24 cm.

ART. 11640 7x9 cm.
ART. 11641 8x10 cm.
ART. 11642 9x12 cm.
ART. 11643 11x15 cm.
ART. 11644 13x18 cm.

ART. 11650 9x12 cm.

Inclinata ovale
ART. 18135 9x12 cm.

ART. 18136 11x15 cm.

Inclinata rettangolare
ART. 18137 9x12 cm.

ART. 18138 11x15 cm.

ART. 18036 9x12 cm.

ART. 18037 11x15 cm.



ART. 11607
9x12 cm.

ART. 11608
11x15 cm.

ART. 11621
9x12 cm.

ART. 11605
9x12 cm.

ART. 11606
11x15 cm.

ART. 11620
9x12 cm.

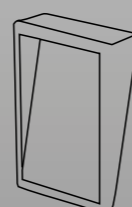

Inclinazione a richiesta su tutti i tipi cornici

PORTARITRATTI



ART. 18030 x cornice 9x12 cm.

ART. 18031 x cornice 11x15 cm.

ART. 18032 x cornice 13x18 cm.

ART. 18033 x cornice 9x12 cm.

ART. 18034 x cornice 11x15 cm.

ART. 18035 x cornice 13x18 cm.

ART. 18104 9x12 cm.

ART. 18105 11x15 cm.

ART. 18107 13x18 cm.

ART. 18126 9x12 cm.

ART. 18127 10x15 cm.

ART. 18128 11x15 cm.

ART. 18133 13x18 cm.

Portaritratti per l'applicazione di qualsiasi tipo di cornice.
Al prezzo del portaritratto va aggiunto il prezzo delle cornici desiderate.

Portaritratti per l'applicazione di qualsiasi tipo di cornice.
Al prezzo del portaritratto va aggiunto il prezzo delle cornici desiderate.



ART. 12205 ↓ 5 ↔ 3 cm.
 ART. 12206 ↓ 6 ↔ 8 cm.
 ART. 12208 ↓ 8 ↔ 4 cm.
 ART. 12210 ↓ 10 ↔ 5 cm.
 ART. 12220 ↓ 21 ↔ 10 cm.



ART. 15600 ↓ 21 ↔ 10 cm.



ART. 12256
 ↓ 6 ↔ 2 cm.



Croci in tubolare parete e terreno
 sezione ↓ 10 ↔ 20 mm.
 ↓ 15 ↔ 25 mm.
 ↓ 20 ↔ 30 mm.
 ↓ 40 ↔ 40 mm.

misure a richiesta
 chiedere preventivo



Cristo
 ART. 12010 ↓ 10 ↔ 9 cm.
 ART. 12017 ↓ 18 ↔ 15 cm.
 ART. 12022 ↓ 23 ↔ 19 cm.



ART. 14450 ↓ 10 ↔ 5 cm.
 ART. 14451 ↓ 15 ↔ 7,5 cm.
 ART. 14452 ↓ 20 ↔ 10 cm.



Croci a parete con Cristo 5x10 mm.
 ART. 14015 ↓ 15 ↔ 10 cm.
 ART. 14020 ↓ 20 ↔ 10 cm.
 ART. 14025 ↓ 25 ↔ 10 cm.
 ART. 14030 ↓ 30 ↔ 10 cm.
 ART. 14035 ↓ 35 ↔ 10 cm.
 ART. 14040 ↓ 40 ↔ 10 cm.



Croci a parete ↓ 5 ↔ 10 mm.
 ART. 12408 ↓ 8 ↔ 4 cm.
 ART. 12410 ↓ 10 ↔ 4 cm.
 ART. 12412 ↓ 12 ↔ 5 cm.
 ART. 12415 ↓ 15 ↔ 5 cm.
 ART. 12420 ↓ 20 ↔ 6 cm.
 ART. 12425 ↓ 25 ↔ 7 cm.
 ART. 12430 ↓ 30 ↔ 8 cm.
 ART. 12435 ↓ 35 ↔ 8 cm.
 ART. 12440 ↓ 40 ↔ 10 cm.

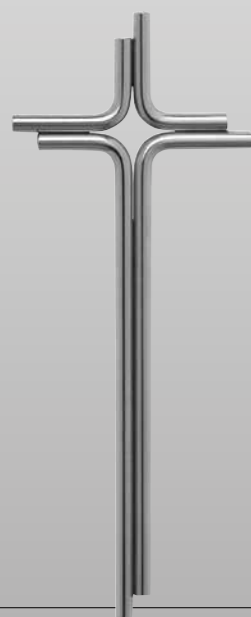

ART. 14531 ↓ 15 ↔ 7 cm.
 ART. 14532 ↓ 20 ↔ 9 cm.
 ART. 14533 ↓ 25 ↔ 11 cm.
 ART. 14534 ↓ 30 ↔ 13 cm.



ART. 14545 ↓ 15 ↔ 7 cm.
 ART. 14546 ↓ 20 ↔ 9 cm.
 ART. 14547 ↓ 25 ↔ 11 cm.
 ART. 14548 ↓ 30 ↔ 13 cm.
 ART. 14535 ↓ 45 ↔ 15 cm.



ART. 14538
 ↓ 45 ↔ 15 cm.



ART. 14250 ↓ 20 ↔ 8 cm.
 ART. 14251 ↓ 30 ↔ 13 cm.



ART. 14260 ↓ 20 ↔ 8 cm.
 ART. 14261 ↓ 30 ↔ 13 cm.

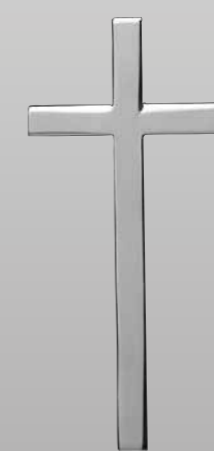

ART. 14297 ↓ 10 cm.
 ART. 14298 ↓ 12 cm.
 ART. 14299 ↓ 15 cm.
 ART. 14300 ↓ 20 cm.
 ART. 14301 ↓ 25 cm.



ART. 14302 ↓ 10 cm.
 ART. 14303 ↓ 12 cm.
 ART. 14304 ↓ 15 cm.
 ART. 14305 ↓ 20 cm.
 ART. 14306 ↓ 25 cm.



ART. 15010
 ↓ 10 ↔ 4 cm.



ART. 14292 ↓ 10 ↔ 5 cm.
 ART. 14293 ↓ 20 ↔ 10 cm.
 ART. 14294 ↓ 30 ↔ 14 cm.
 ART. 14295 ↓ 40 ↔ 16 cm.
 ART. 14296 ↓ 50 ↔ 16 cm.



ART. 14282 ↓ 10 ↔ 5 cm.
 ART. 14283 ↓ 20 ↔ 10 cm.
 ART. 14284 ↓ 30 ↔ 14 cm.
 ART. 14285 ↓ 40 ↔ 16 cm.
 ART. 14286 ↓ 50 ↔ 16 cm.



ART. 14267 ↓ 10 ↔ 5 cm.
 ART. 14268 ↓ 20 ↔ 10 cm.
 ART. 14269 ↓ 30 ↔ 14 cm.
 ART. 14270 ↓ 40 ↔ 16 cm.
 ART. 14271 ↓ 50 ↔ 16 cm.

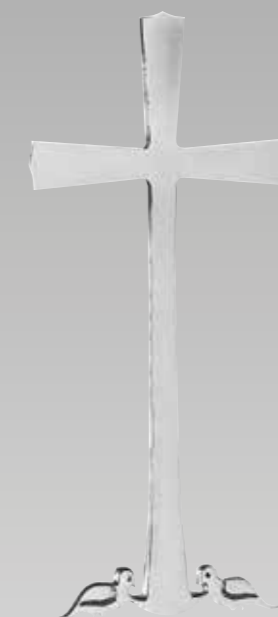

ART. 14277 ↓ 10 ↔ 5 cm.
 ART. 14278 ↓ 20 ↔ 10 cm.
 ART. 14279 ↓ 30 ↔ 14 cm.
 ART. 14280 ↓ 40 ↔ 16 cm.
 ART. 14281 ↓ 50 ↔ 16 cm.



ART. 14272 ↓ 10 ↔ 5 cm.
 ART. 14273 ↓ 20 ↔ 10 cm.
 ART. 14274 ↓ 30 ↔ 14 cm.
 ART. 14275 ↓ 40 ↔ 16 cm.
 ART. 14276 ↓ 50 ↔ 16 cm.

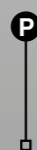

ART. 14287 ↓ 10 ↔ 5 cm.
 ART. 14288 ↓ 20 ↔ 10 cm.
 ART. 14289 ↓ 30 ↔ 14 cm.
 ART. 14290 ↓ 40 ↔ 16 cm.
 ART. 14291 ↓ 50 ↔ 16 cm.

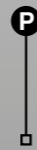

ART. 14262 ↓ 10 ↔ 5 cm.
 ART. 14263 ↓ 20 ↔ 10 cm.
 ART. 14264 ↓ 30 ↔ 14 cm.
 ART. 14265 ↓ 40 ↔ 16 cm.
 ART. 14266 ↓ 50 ↔ 16 cm.





ART. 16074
fiamma Ø 5
↓ 12 ↔ 8,5 cm.

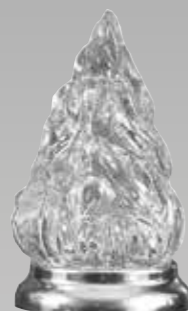

ART. 16076
fiamma Ø 5
↓ 12 ↔ 7 cm.

ART. 16076SF
solo ghiera



ART. 16075
fiamma Ø 4
↓ 10 ↔ 6,5 cm.

ART. 16080
↓ 13 ↔ 6,5 cm.
per fiamma Ø 5
con attacco Ø 4



ART. 16077
fiamma Ø 4
↓ 8,5 ↔ 6 cm.

ART. 16077SF
solo ghiera



* Borchia
ART. 10866 Ø 4 cm.

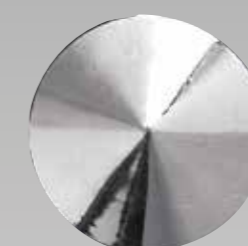

Borchia
* **ART. 10800** Ø 2,5 cm.

* **ART. 10810** Ø 3,5 cm.

* **ART. 10820** Ø 5 cm.

* **ART. 10821** Ø 6 cm.

ART. 10830 Ø 7,5 cm.

perno Ø 8 MA



* Borchie
ART. 10840 ↓ 3,5 ↔ 3,5 cm.

ART. 10850 ↓ 4 ↔ 4 cm.

ART. 10860 ↓ 5 ↔ 5 cm.



ART. 16079
fiamma Ø 5
↓ 12 ↔ 7 cm.



ART. 16081 Ø 4
↓ 9 ↔ 6 cm.



* Borchie in acciaio pesante
ART. 10831 Ø 2,5 cm.

ART. 10832 Ø 3 cm.

ART. 10833 Ø 4 cm.

ART. 10834 Ø 5 cm.



* Borchia
ART. 10867 Ø 5 cm.

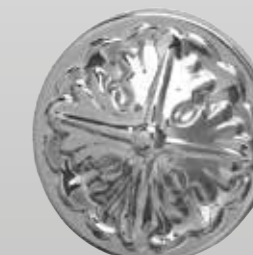

* Borchie in acciaio pesante
ART. 10869 Ø 3,5 cm.

ART. 10870 Ø 5 cm.



Ghiera Inox
ART. 16082 Ø 5
↓ 13 ↔ 7 cm.



Ghiera Inox Disassata
ART. 16083 Ø 5
↓ 13 ↔ 7 cm.

* I prezzi delle borchie si intendono senza perni e sono predisposte di serie per il perno di Ø 5 MA - **ART. 91150**

I: Avvertenze per l'utente: le staffe o borchie portanti, raffigurate nel presente catalogo, sono realizzate con materiale di qualità tale da consentire il mantenimento nel tempo delle loro caratteristiche. La funzionalità e la sicurezza delle stesse è condizionata alla corretta installazione che prevede l'utilizzo di due staffe o borchie sul lato inferiore e due sul lato superiore di ogni lastra coprolucolo.

GB: Note for the user: the support brackets or load bearing stud, shown in this catalogue, have been made with special quality material that maintains its characteristics with the passing of time. The functionality and safety of these items depends upon their correct installation, which provides for the use of two brackets or studs on the lower side and two on the upper side of each loculus cover slab/plate.

Borchia regolabile portante a croce

ART. 10805 Ø 2,5 cm.

ART. 10815 Ø 3,5 cm.

ART. 10825 Ø 5 cm.

prezzo del perno escluso



ART. 10650 Ø 4,5 cm.

ART. 10845 Ø 5 cm.
 Perno Ø 8 MA x 130
 compreso nel prezzo.

I: Avvertenze per l'utente: le staffe o borchie portanti, raffigurate nel presente catalogo, sono realizzate con materiale di qualità tale da consentire il mantenimento nel tempo delle loro caratteristiche. La funzionalità e la sicurezza delle stesse è condizionata alla corretta installazione che prevede l'utilizzo di due staffe o borchie sul lato inferiore e due sul lato superiore di ogni lastra coprolucolo.

GB: Note for the user: the support brackets or load bearing stud, shown in this catalogue, have been made with special quality material that maintains its characteristics with the passing of time. The functionality and safety of these items depends upon their correct installation, which provides for the use of two brackets or studs on the lower side and two on the upper side of each loculus cover slab/plate.

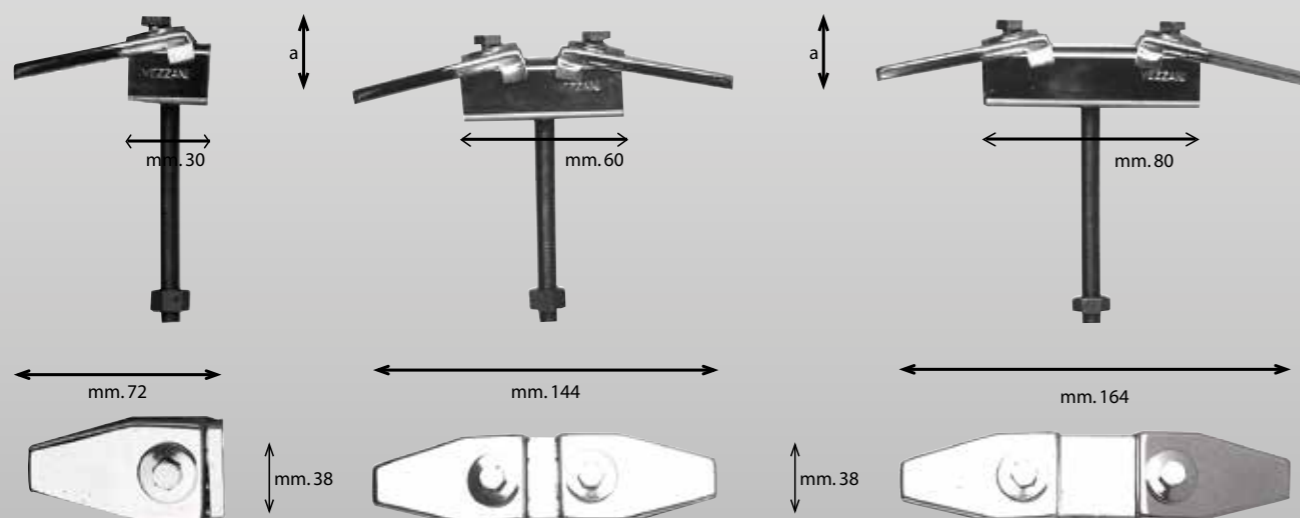
Staffe regolabili portanti per marmo da mm. 7-22

ART. 10875
 a=mm. 7-22

ART. 10876
 a=mm. 7-22

ART. 10877
 a=mm. 7-22

a= spessore marmo

Perno Ø 8 MA x90 compreso nel prezzo

F: Avertissements pour l'utilisateur: les étriers ou les joints portant, illustrés dans ce catalogue, ont été réalisés dans un matériau leur permettant de conserver le niveau de leurs caractéristiques dans le temps. Le caractère fonctionnel de ces derniers dépend d'une parfaite installation, qui prévoit l'utilisation de deux étriers ou joints sur le côté inférieur et deux sur le côté supérieur de chaque plaque protège-logement.

E: Advertencia: las borchias portátiles incluidas en este catálogo, se han realizado con material de elevada calidad para conseguir el mantenimiento de las características en el tiempo. La funcionalidad y seguridad de las mismas, depende de la correcta instalación de dos borchias en el lado inferior y dos en el lado superior de cada lápida.

esempio di staffe regolabili portanti montate



F: Avertissements pour l'utilisateur: les étriers ou les joints portant, illustrés dans ce catalogue, ont été réalisés dans un matériau leur permettant de conserver le niveau de leurs caractéristiques dans le temps. Le caractère fonctionnel de ces derniers dépend d'une parfaite installation, qui prévoit l'utilisation de deux étriers ou joints sur le côté inférieur et deux sur le côté supérieur de chaque plaque protège-logement.

E: Advertencia: las borchias portátiles incluidas en este catálogo, se han realizado con material de elevada calidad para conseguir el mantenimiento de las características en el tiempo. La funcionalidad y seguridad de las mismas, depende de la correcta instalación de dos borchias en el lado inferior y dos en el lado superior de cada lápida.



Catena
ART. 11200
maglia 5 cm.
prezzo al metro



Catena
ART. 11210
maglia 10 cm.
prezzo al metro



ART. 18650
↓ 14 ↔ 12 cm.



ART. 18600
↓ 15 ↔ 9 cm.



Perni
ART. 91450 5 MA ↔ 50 mm.
ART. 91460 5 MA ↔ 60 mm.
ART. 91470 5 MA ↔ 70 mm.



Perno **ART. 91130**
3 MA X 35
Perno **ART. 91140**
4 MA X 50
Perno **ART. 91150**
5 MA X 50
Perno **ART. 91154**
6 MA X 60
Perno **ART. 91160**
5 MA X 60
Perno **ART. 91170**
5 MA X 70
Perno **Art. 91180**
5 MA X 80



Perni
ART. 91570 Ø ↓ 5 ↔ 70 mm.
ART. 91580 Ø ↓ 6 ↔ 80 mm.
ART. 91590 Ø ↓ 8 ↔ 100 mm.
ART. 91599 Ø ↓ 10 ↔ 100 mm.



Inox
ART. 91155
8 MA ↔ 100 mm.
ART. 91156
10 MA ↔ 100 mm.



Perni
ART. 91340 TPS da 40 mm.
ART. 91350 TPS da 50 mm.
ART. 91360 TPS da 60 mm.
ART. 91370 TPS da 70 mm.

ABCD

Caratteri

inox

Borsivo

Millennium

12.2.2006



Corsivo
Boutique
inox

ART. 5218 Lettere/Numeri ↓ mm. 15 spessore mm. 2,5

ART. 5224 Lettere/Numeri ↓ mm. 20 spessore mm. 2,5

ART. 5229 Lettere/Numeri ↓ mm. 25 spessore mm. 2,5

ART. 5234 Lettere/Numeri ↓ mm. 30 spessore mm. 2,5

ART. 5244 Lettere/Numeri ↓ mm. 40 spessore mm. 2,5

ART. 5254 Lettere/Numeri ↓ mm. 50 spessore mm. 2,5

ART. 5264 Lettere/Numeri ↓ mm. 60 spessore mm. 2,5

ART. 5284 Lettere/Numeri ↓ mm. 80 spessore mm. 2,5

ART. 5297 Lettere/Numeri ↓ mm. 100 spessore mm. 2,5

Punteggiatura gratuita fino al mm. 50. Doratura: aumento del 60%

Lettere e Numeri sciolti: aumento del 20%

• È possibile richiedere il carattere Boutique di qualsiasi misura, previo preventivo.

• I numeri sono da intendersi su barretta se non diversamente specificato al momento dell'ordine.

• Negli ordini citare sempre l'altezza delle lettere minuscole a corpo semplice (a-c-m-etc...)

• Le lettere maiuscole hanno un'altezza superiore alle lettere minuscole del 100% circa e vengono conteggiate allo stesso prezzo delle lettere minuscole

• Le date possono essere richieste solamente appoggiate sull'asta.

• L'altezza delle date è da intendersi asta compresa.

Free punctuation up to 50 mm. Gilding: 60% increase.

Loose letters and numbers: 20% increase.

• It is possible to ask for the font Boutique in any size, after a price estimate.

• The numbers are to be meant on underscore if not differently specified at the order.

• In the orders always indicate the height of the lower-case letters in simple type size (a-c-m-, etc...).

• The upper-case letters are higher by about 100% than the lower-case letters, and are counted in the same way as the lower-case letters.

• THE HEIGHT OF THE DATES ARE ALWAYS INDICATED NUMBER INCLUDED UNDERSCORE.

A B C D E F G	a b c d e f g h i
H I J K L M N	j k l m n o p q r
O P Q R S T U	s e t u v w x y
V W X Y Z	1 2 3 4 5 6 7 8 9 0 ☆ †

Vezzani

Vezzani

12.2.2004

VEZZANI

VEZZANI

12.2.2006

- Per misure superiori chiedere preventivo
- Il corsivo può essere richiesto: **compresso - standard - allargato**
- Le date possono essere: **incorporate - appoggiate**
- **Sciolte (con aumento del 20%)**
- L'altezza delle date è da intendersi asta compresa.

- ART. 5235 Lettere/Numeri ↓ mm. 15 spessore mm. 2,5
- ART. 5236 Lettere/Numeri ↓ mm. 20 spessore mm. 2,5
- ART. 5237 Lettere/Numeri ↓ mm. 25 spessore mm. 2,5
- ART. 5238 Lettere/Numeri ↓ mm. 30 spessore mm. 2,5
- ART. 5239 Lettere/Numeri ↓ mm. 40 spessore mm. 2,5
- ART. 5245 Lettere/Numeri ↓ mm. 50 spessore mm. 2,5
- ART. 5246 Lettere/Numeri ↓ mm. 60 spessore mm. 2,5
- ART. 5247 Lettere/Numeri ↓ mm. 80 spessore mm. 2,5
- ART. 5248 Lettere/Numeri ↓ mm. 100 spessore mm. 2,5

- For sizes bigger ask for an estimate
- Dates can be: inside the bar - on the bar - loose (increase by 20%)
- THE HEIGHT OF THE DATES ARE ALWAYS INDICATED NUMBER INCLUDED UNDERSCORE.

Punteggiatura gratuita fino al mm. 50. Doratura: aumento del 60%
 Lettere e Numeri sciolti: aumento del 20%
 • È possibile richiedere il carattere Corsivo Plain di qualsiasi misura, previo preventivo.
 • I numeri sono da intendersi su barretta se non diversamente specificato al momento dell'ordine.
 • Negli ordini citare sempre l'altezza delle lettere minuscole a corpo semplice (a-c-m-etc...)
 • Le lettere maiuscole hanno un'altezza superiore alle lettere minuscole del 40% circa e vengono conteggiate allo stesso prezzo delle lettere minuscole

Free punctuation up to 50 mm. Gilding: 60% increase
 Loose letters and numbers: 20% increase
 • It is possible to ask for the font Plain italics in any size, after a price estimate
 • The numbers are to be meant on underscore if not differently specified at the order
 • In the orders always indicate the height of the lower-case letters in simple type size (a-c-m-, etc...)
 • The upper-case letters are higher by about 40% than the lower-case letters, and are counted in the same way as the lower-case letters

- Le date possono essere richieste
- a corpo unico distanziate con punto
- sciolte (aumento 20%)
- Non c'è maiuscola, le lettera hanno tutte la stessa altezza

- ART. 5255 Lettere/Numeri ↓ mm. 15 spessore mm. 2,5
- ART. 5256 Lettere/Numeri ↓ mm. 20 spessore mm. 2,5
- ART. 5257 Lettere/Numeri ↓ mm. 25 spessore mm. 2,5
- ART. 5258 Lettere/Numeri ↓ mm. 30 spessore mm. 2,5
- ART. 5259 Lettere/Numeri ↓ mm. 40 spessore mm. 2,5
- ART. 5265 Lettere/Numeri ↓ mm. 50 spessore mm. 2,5
- ART. 5266 Lettere/Numeri ↓ mm. 60 spessore mm. 2,5
- ART. 5267 Lettere/Numeri ↓ mm. 80 spessore mm. 2,5
- ART. 5268 Lettere/Numeri ↓ mm. 100 spessore mm. 2,5

- Dates can be ordered: - as a unique piece divided by a point - loose (increase by 20%)
- There is no capital letter, letters have all the same height

- Für Ausmaße größer fragen Sie für einen Kostenvorschlag
- Datum können bestellt werden: - wie ein einziges Stück das von einem Punkt getrennt wird - lose (Zunahme vom 20%)
- Es gibt keine Großbuchstabe, Buchstabe haben die selbe Höhe

Punteggiatura gratuita fino al mm. 50
 Doratura: aumento del 60%

Free punctuation up to 50 mm
 Gilding: 60% increase

A B C D E F G H I
 J K L M N O P Q R
 S T U V W X Y a b c d e f g h i j k l m
 n o p q r s t u v w x y
 1 2 3 4 5 6 7 8 9 0 † ☆ ▲ Ω

A B C D E F G H I J K L M
 N O P Q R S T U V W X Y
 1 2 3 4 5 6 7 8 9 0
 † ☆ ▲ Ω

Corsivo Millennium

IL CORSIVO MILLENNIUM PUÒ ESSERE RICHIESTO:

COMPRESSO

Millennium

STANDARD

Millennium

ALLARGATO

Millennium

LE DATE POSSONO ESSERE RICHIESTE:

INCORPORATE NELL'ASTA

M. 10 12 2003

APPOGGIATE NELL'ASTA

M. 10 12 2003

SE AL MOMENTO DELL'ORDINE NON VIENE EFFETTUATA ALCUNA SPECIFICAZIONE, IL CORSIVO VIENE PRODOTTO AUTOMATICAMENTE STANDARD E CON DATE INCORPORATE NELL'ASTA.

ART. 5215 Lettere/Numeri ↓ mm. 15 spessore mm. 2,5

ART. 5222 Lettere/Numeri ↓ mm. 20 spessore mm. 2,5

ART. 5227 Lettere/Numeri ↓ mm. 25 spessore mm. 2,5

ART. 5232 Lettere/Numeri ↓ mm. 30 spessore mm. 2,5

ART. 5242 Lettere/Numeri ↓ mm. 40 spessore mm. 2,5

ART. 5252 Lettere/Numeri ↓ mm. 50 spessore mm. 2,5

ART. 5262 Lettere/Numeri ↓ mm. 60 spessore mm. 2,5

ART. 5282 Lettere/Numeri ↓ mm. 80 spessore mm. 2,5

ART. 5293 Lettere/Numeri ↓ mm. 100 spessore mm. 2,5

A B C D E F G H a b c d e f g h i
J K L M N O P j k l m n o p q r
Q R S T U V W s e t u v w x z
X Y Z 1 2 3 4 5 6 7 8 9 0 † ☆ ▲ Ω

- ① Punteggiatura gratuita fino al mm. 50
Doratura: aumento del 60%
Lettere e Numeri sciolti: aumento del 20%
• È possibile richiedere il carattere Corsivo Millennium di qualsiasi misura, previo preventivo.
• I numeri sono da intendersi su barretta se non diversamente specificato al momento dell'ordine.
• Negli ordini citare sempre l'altezza delle lettere minuscole a corpo semplice (a-c-m-etc...)
• Le lettere maiuscole hanno un'altezza superiore alle lettere minuscole del 140% circa e vengono conteggiate allo stesso prezzo delle lettere minuscole.
• L'altezza delle date è da intendersi asta compresa.

- ② Punctuation gratuite jusqu'au 50e millimètre
Dorure : 60 % de majoration
Lettres et chiffres à l'unité : 20 % de majoration
• La police Millennium italique est disponible sur demande dans tous les formats, contre devis
• Les chiffres sont soulignés sauf spécification différente sur la commande
• Veuillez toujours préciser sur la commande la taille des lettres en minuscules en style normal (a-c-m-, etc.)
• La taille des majuscules est plus grande d'environ 140 % que celle des minuscules. Les majuscules sont calculées au même prix que les minuscules.

- ③ Free punctuation up to 50 mm
Gilding: 60% increase
Loose letters and numbers: 20% increase
• It is possible to ask for the font Millennium italics in any size, after a price estimate
• The numbers are to be meant on underscore if not differently specified at the order
• In the orders always indicate the height of the lower-case letters in simple type size (a-c-m-, etc...)
• The upper-case letters are higher by about 140% than the lower-case letters, and are counted in the same way as the lower-case letters.
• THE HEIGHT OF THE DATES ARE ALWAYS INDICATED NUMBER INCLUDED UNDERSCORE.

- ④ Punteado gratuito hasta el milímetro 50
Dorado: aumento del 60%
Letras y números sueltos: aumento del 20%
• Se puede solicitar la fuente Cursiva Millennium de cualquier tamaño, previo presupuesto.
• Los números deben entenderse sobre barra, si no se especifica otra cosa al hacer el pedido.
• En los pedidos se debe mencionar siempre la altura de las letras, minúsculas de cuerpo sencillo (a-c-m etc.)
• La altura de las letras mayúsculas es un 140% mayor que la de las letras minúsculas, y se cuentan al mismo precio.

- ⑤ Bis zu 50 mm kostenlose Zeichensetzung
Vergoldung: 60% Aufschlag
Lose Buchstaben und Ziffern: 20% Aufschlag
• Nach Kostenvoranschlag kann man die Schriftart Millennium kursiv in jeder Größe anfordern
• Die Nummern sind, falls bei der Bestellung nichts anderes angegeben wird, unterstrichen
• In den Bestellungen immer die Schriftgröße der Kleinbuchstaben mit einfacher Form angeben (Bsp. a-c-m)
• Großbuchstaben sind ca. 140% höher als Kleinbuchstaben und werden zum gleichen Preis wie die Kleinbuchstaben berechnet

- ⑥ Pontuação gratuita até 50 mm.
Douradura: aumento de 60%
Letras e números avulsos: aumento de 20%
• É possível solicitar o carácter Itálico Millennium de qualquer medida, prévio orçamento.
• Os números devem ser entendidos em barras se não for especificado diferentemente no momento da encomenda.
• Nas encomendas citar sempre a altura das letras maiúsculas com corpo simples (a-c-m-etc...)
• As letras maiúsculas são mais altas cerca de 140% do que as letras minúsculas e são calculadas usando o mesmo preço das letras minúsculas.

Carattere Digivi

IL CORSIVO MILLENIUM PUÒ ESSERE RICHIESTO:

COMPRESSO

STANDARD

ALLARGATO

ART. 5216 Lettere/Numeri ↓ mm. 15 spessore mm. 2,5

ART. 5223 Lettere/Numeri ↓ mm. 20 spessore mm. 2,5

ART. 5228 Lettere/Numeri ↓ mm. 25 spessore mm. 2,5

ART. 5233 Lettere/Numeri ↓ mm. 30 spessore mm. 2,5

ART. 5243 Lettere/Numeri ↓ mm. 40 spessore mm. 2,5

ART. 5253 Lettere/Numeri ↓ mm. 50 spessore mm. 2,5

ART. 5263 Lettere/Numeri ↓ mm. 60 spessore mm. 2,5

ART. 5283 Lettere/Numeri ↓ mm. 80 spessore mm. 2,5

ART. 5294 Lettere/Numeri ↓ mm. 100 spessore mm. 2,5

A B C D E F G a b c d e f g h i
 H I J K L M j k l m n o p q r
 N O P Q R S T s e t u u u x z
 U V W X Y Z 1 2 3 4 5 6 7 8 9 0 † ☆

- I** Punteggiatura gratuita fino al mm. 50
 Doratura: aumento del 60%
 Lettere e Numeri sciolti: aumento del 20%
 • È possibile richiedere il carattere Digivi di qualsiasi misura, previo preventivo.
 • I numeri sono da intendersi su barretta se non diversamente specificato al momento dell'ordine.
 • Negli ordini citare sempre l'altezza delle lettere minuscole a corpo semplice (a-c-m-etc...)
 • Le lettere maiuscole hanno un'altezza superiore alle lettere minuscole del 100% circa e vengono conteggiate allo stesso prezzo delle lettere minuscole
 • Le date possono essere richieste solamente appoggiate sull'asta.
 • L'altezza delle date è da intendersi asta compresa.

- GB** Free punctuation up to 50 mm
 Gilding: 60% increase
 Loose letters and numbers: 20% increase
 • It is possible to ask for the font Digivi in any size, after a price estimate
 • The numbers are to be meant on underscore if not differently specified at the order
 • In the orders always indicate the height of the lower-case letters in simple type size (a-c-m-, etc...)
 • The upper-case letters are higher by about 100% than the lower-case letters, and are counted in the same way as the lower-case letters.
 • THE HEIGHT OF THE DATES ARE ALWAYS INDICATED NUMBER INCLUDED UNDERSCORE.

- D** Bis zu 50 mm kostenlose Zeichensetzung
 Vergoldung: 60% Aufschlag
 Lose Buchstaben und Ziffern: 20% Aufschlag
 • Nach Kostenvoranschlag kann man die Digivi kursiv in jeder Größe anfordern
 • Die Nummern sind, falls bei der Bestellung nichts anderes angegeben wird, unterstrichen
 • In den Bestellungen immer die Schriftgröße der Kleinbuchstaben mit einfacher Form angeben (Bsp. a-c-m)
 • Großbuchstaben sind ca. 100% höher als Kleinbuchstaben und werden zum gleichen Preis wie die Kleinbuchstaben berechnet

- F** Punctuation gratuite jusqu'au 50e millimètre
 Dorure : 60 % de majoration
 Lettres et chiffres à l'unité : 20 % de majoration
 • La police Digivi est disponible sur demande dans tous les formats, contre devis
 • Les chiffres sont soulignés sauf spécification différente sur la commande
 • Veuillez toujours préciser sur la commande la taille des lettres en minuscules en style normal (a-c-m-, etc.)
 • La taille des majuscules est plus grande d'environ 100 % que celle des minuscules.
 Les majuscules sont calculées au même prix que les minuscules.

- E** Punteado gratuito hasta el milímetro 50
 Dorado: aumento del 60%
 Letras y números sueltos: aumento del 20%
 • Se puede solicitar la fuente Digivi de cualquier tamaño, previo presupuesto.
 • Los números deben entenderse sobre barra, si no se especifica otra cosa al hacer el pedido.
 • En los pedidos se debe mencionar siempre la altura de las letras, minúsculas de cuerpo sencillo (a-c-m etc.)
 • La altura de las letras mayúsculas es un 100% mayor que la de las letras minúsculas, y se cuentan al mismo precio.

- P** Pontuação gratuita até 50 mm.
 Doradura: aumento de 60%
 Letras e números avulsos: aumento de 20%
 • É possível solicitar o carácter Digivi de qualquer medida, prévio orçamento.
 • Os números devem ser entendidos em barras se não for especificado diferentemente no momento da encomenda.
 • Nas encomendas citar sempre a altura das letras maiúsculas com corpo simples (a-c-m-etc...)
 • As letras maiúsculas são mais altas cerca de 100% do que as letras minúsculas e são calculadas usando o mesmo preço das letras minúsculas.

ANTARES

A B C D E F G H K
I J L M N O P Q R S
T U V W X Y Z
1 2 3 4 5 6 7 8 0 ★ † P

- ART. 5217 Lettere/Numeri ↓ mm. 15 spessore mm. 2,5
- ART. 5220 Lettere/Numeri ↓ mm. 20 spessore mm. 2,5
- ART. 5225 Lettere/Numeri ↓ mm. 25 spessore mm. 2,5
- ART. 5230 Lettere/Numeri ↓ mm. 30 spessore mm. 2,5
- ART. 5240 Lettere/Numeri ↓ mm. 40 spessore mm. 2,5
- ART. 5250 Lettere/Numeri ↓ mm. 50 spessore mm. 2,5
- ART. 5260 Lettere/Numeri ↓ mm. 60 spessore mm. 2,5
- ART. 5280 Lettere/Numeri ↓ mm. 80 spessore mm. 2,5
- ART. 5290 Lettere/Numeri ↓ mm. 100 spessore mm. 2,5
- ART. 5291 Lettere/Numeri ↓ mm. 120 spessore mm. 2,5
- ART. 5295 Lettere/Numeri ↓ mm. 150 spessore mm. 2,5
- ART. 5296 Lettere/Numeri ↓ mm. 200 spessore mm. 2,5

- È possibile richiedere il carattere Antares di qualsiasi misura previo preventivo.
- I numeri si intendono su barretta.
- Per lettere e numeri singoli aumento del 20%.
- L'altezza delle date è da intendersi asta compresa.

- It is possible to ask for the font Antares in upon estimate.
- The numbers are to be meant on underscore if not differently specified at the order.
- For single letters and numbers: increase 20%.
THE HEIGHT OF THE DATES ARE ALWAYS INDICATED NUMBER INCLUDED UNDERSCORE.

A B C D E F G H I J K L M
N O P Q R S T U V W X Y
1 2 3 4 5 6 7 8 9 0 † ★ Δ Ω

PER COMPOSIZIONI EPIGRAFICI AUMENTO DEL 20%

- ART. 5420 Lettere/Numeri/Stella/Croce ↓ mm.20
- ART. 5425 Lettere/Numeri/Stella/Croce ↓ mm.25
- ART. 5435 Lettere/Numeri/Stella/Croce ↓ mm.35
- ART. 5445 Lettere ↓ mm.45
- ART. 5460 Lettere ↓ mm.60
- ART. 5461 Pax ↓ mm.60
- ART. 5480 Pax ↓ mm.80
- ART. 5491 Pax ↓ mm.100
- ART. 5496 Trattino per ↓ 20-25-35-45-60 mm.
- ART. 5497 Virgola per ↓ 20-25-35-45-60 mm.
- ART. 5499 Punto per ↓ 20-25-35-45-60 mm.

A B C D E F G

H K I J L M N

O P Q R S T U

V W X Y Z

1 2 3 4 5 6 7

8 9 0 ★ † - · ,

A B C D E F G

H K I J L M N

O P Q R S T U

V W X Y Z

1 2 3 4 5 6 7

8 9 0 ★ † - · ,

ART. 5826 Lettere/Numeri/Stella/Croce ↓ mm.25

ART. 5831 Lettere/Numeri/Stella/Croce ↓ mm.30

ART. 5841 Lettere ↓ mm.40

ART. 5851 Lettere ↓ mm.50

ART. 5893 Trattino per ↓ 25-30-40-50 mm.

ART. 5894 Virgola per ↓ 25-30-40-50 mm.

ART. 5895 Punto per ↓ 25-30-40-50 mm.

PER COMPOSIZIONI EPIGRAFI AUMENTO DEL 20%

ART. 5825 Lettere/Numeri/Stella/Croce ↓ mm.25

ART. 5830 Lettere/Numeri/Stella/Croce ↓ mm.30

ART. 5840 Lettere ↓ mm.40

ART. 5850 Lettere ↓ mm.50

ART. 5891 Lettere ↓ mm.100

ART. 5896 Trattino per ↓ 25-30-40-50 mm.

ART. 5828 Virgola per ↓ 25-30-40-50 mm.

ART. 5899 Punto per ↓ 25-30-40-50 mm.

A B C D E F G

H K I J L M N

O P Q R S T U

V W X Y Z

1 2 3 4 5 6 7

8 9 0 ★ † - .

La superficie di adesione deve essere perfettamente piana e levigata - marmo, granito, vetro, cristallo, ecc.



1 Pulire accuratamente la lastra con alcool.



2 Tracciare a matita la linea di posizionamento del carattere, oppure usare un righello.



3 Togliere la protezione in carta dell'adesivo, avendo cura di non toccarlo con le mani.



4 Posizionare la lettera allineandola al segno a matita. L'applicazione deve essere eseguita a temperatura ambiente.



5 Premere con forza per qualche secondo.

Le operazioni necessarie per il montaggio del carattere Futuro autoadesivo sono identiche al procedimento di applicazione del carattere Romano autoadesivo.

Questo fissaggio rende possibili rapide realizzazioni con la sicurezza di un adesivo resistente a temperatura da -30°C a + 100°C.

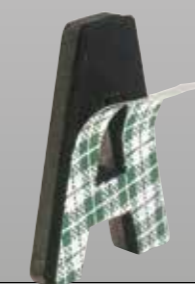

PER COMPOSIZIONI EPIGRAFI AUMENTO DEL 20%

ART. 5827	Lettere/Numeri/Stella/Croce	↑ mm.25
ART. 5832	Lettere/Numeri/Stella/Croce	↑ mm.30
ART. 5842	Lettere	↑ mm.40
ART. 5852	Lettere	↑ mm.50
ART. 5892	Virgola	per ↑ 20-30-40-50 mm.
ART. 5897	Trattino	per ↑ 20-30-40-50 mm.
ART. 5898	Punto	per ↑ 20-30-40-50 mm.

A B C D E F G

H K I J L M N

O P Q R S T U

V W X Y Z

1 2 3 4 5 6 7

8 9 0 ★ † - , '

A B C D E F G H K

I J L M N O P Q R S

T U V W X Y Z

1 2 3 4 5 6 7 8 0 ★ †

PER COMPOSIZIONI EPIGRAFI AUMENTO DEL 20%

ART. 5725	Lettere/Numeri	↑ mm.25
ART. 5735	Lettere/Numeri	↑ mm.35
ART. 5745	Lettere	↑ mm.45
ART. 5760	Lettere	↑ mm.60
ART. 5497	Virgola	per ↑ 25-35-45-60 mm.
ART. 5596	Trattino	per ↑ 25-35-45-60 mm.
ART. 5599	Punto	per ↑ 25-35-45-60 mm.

PER COMPOSIZIONI EPIGRAFI AUMENTO DEL 20%

ART. 5120	Lettere/Numeri/Stella/Croce	↑ mm.20
ART. 5130	Lettere/Numeri/Stella/Croce	↑ mm.30
ART. 5140	Lettere	↑ mm.40
ART. 5150	Lettere	↑ mm.50
ART. 5160	Pax	↑ mm.60
ART. 5180	Pax	↑ mm.80
ART. 5497	Virgola	per ↑ 25-30-40-50 mm.
ART. 5496	Trattino	per ↑ 25-30-40-50 mm.
ART. 5199	Punto	per ↑ 25-30-40-50 mm.



PER COMPOSIZIONI EPIGRAFI AUMENTO DEL 20%

ART. 5525 Lettere/Numeri	↓ mm.25
ART. 5545 Lettere	↓ mm.45
ART. 5497 Virgola	per ↓ 25-45 mm.
ART. 5596 Trattino	per ↓ 25-45 mm.
ART. 5599 Punto	per ↓ 25-45 mm.

Urne





Urna Rame
ART. 45610
↓ 27 ↔ 15,5
capacità cm³ 3500



ART. 45711
Ø 17 ↓ 28
capacità cm³ 3600



Urna Bronzo
ART. 45713
↓ 28 Ø 17 cm.
capacità cm³ 3600



Urna Cubo
ART. 45533
↓ 20 ↔ 14 ↗ 14,5 cm.
capacità cm³ 3750



Urna Cubo
ART. 45534
↓ 20 ↔ 14 ↗ 14,5 cm.
capacità cm³ 3750



Urna Cineraria
ART. 45537
↓ 24 ↔ 12,5 ↗ 12,5 cm.
capacità cm³ 3300



ART. 45712
↓ 28 ↔ 17 cm.
capacità cm³ 3600



Urna Ottagonale
ART. 45615
↓ 20 ↔ 14 ↗ 14 cm.
capacità cm³ 3500



Urna Cineraria
ART. 45536
↓ 20,5 ↔ 16 ↗ 16 cm.
capacità cm³ 4700



Urna Ottagonale
ART. 45620
↓ 20 ↔ 14 ↗ 14 cm.
capacità cm³ 3500

Mini Urne



ART. 45526
↓ 6,5 ↔ 3,5 cm.
capacità cm³ 8



ART. 45523
↓ 6 ↔ 3,5 cm.
capacità cm³ 10



ART. 45522
↓ 7 ↔ 3,5 cm.
capacità cm³ 10



ART. 45521
↓ 6,5 ↔ 4 cm.
capacità cm³ 10



CASSETTA PORTACENERI INOX
ART. 15550

↓ 11,5 ↔ 25 ↗ 13,5 cm.

ART. 15551

↓ 16,5 ↔ 25 ↗ 13,5 cm.



ART. 15501 lucida

ART. 15505 satinato
↓ 16 ↔ 22 ↗ 16 cm.
capacità cm³ 5200



ART. 15500 lucida

ART. 15508 satinato
↓ 16 ↔ 24 ↗ 16 cm.
capacità cm³ 5200



ART. 15520

↓ 22 ↔ 14,5 ↗ 17,5 cm.
capacità cm³ 5750



Mini urna
ART. 15516

↓ 10,5 ↔ 7,5 ↗ 7,5 cm.
capacità cm³ 500



ART. 45550

↓ Ø 16 cm.

capacità cm³ 4600



ART. 45549

↓ 23 Ø 16 cm.

capacità cm³ 4600



ART. 45548

↓ 23 Ø 16 cm.

capacità cm³ 4600



ART. 45546

↓ 23 Ø 16 cm.

capacità cm³ 4600



ART. 45547

↓ 23 Ø 16 cm.

capacità cm³ 4600



ART. 15602

↓ 25,5 Ø 19,5 cm.

capacità cm³ 4600



ART. 45500

↓ 25,5 Ø 19,5 cm.

capacità cm³ 4600

Predisposte alla piombatura con 2 fori +2 viti Sabattini + sacchetto in polietilene

Ready for plumbing with 2 holes + 2 Sabattini screws + polythene bag

Plombage possible : 2 trous+2 vis Sabattini+sachet en polyéthylène

Für die Verbleiung vorbereitet mit 2 Bohrungen +2 Sabattinisrauben+Polyethylenbeutel

Predispuestas para la emplomadura con 2 agujeros + 2 tornillos Sabattini + bolsa de polietileno



ART. 29805
 ↓ 27 ↔ 16
 capacità cm³ 3750



ART. 29821
 ↓ 27 ↔ 16
 capacità cm³ 3750



ART. 29842
 ↓ 29 ↔ 23
 capacità cm³ 6800



ART. 29841
 ↓ 29 ↔ 23
 capacità cm³ 6800



ART. 29804
 ↓ 27 ↔ 16
 capacità cm³ 3750



ART. 29803
 ↓ 27 ↔ 16
 capacità cm³ 3750



ART. 29840
 ↓ 29 ↔ 23
 capacità cm³ 6800



ART. 29801
 ↓ 27 ↔ 16
 capacità cm³ 3750



ART. 29802
 ↓ 27 ↔ 16
 capacità cm³ 3750



ART. 29820
 ↓ 27 ↔ 16
 capacità cm³ 3750



ART. 29857
 † 25 Ø 21 cm.
 capacità 6000 cm³



ART. 29860
 † 25,5 Ø 22 cm.
 capacità 6000 cm³



ART. 29863
 † 25 Ø 20 cm.
 capacità 5500 cm³



ART. 29858
 † 25 Ø 21 cm.
 capacità 6000 cm³



ART. 29861
 † 25,5 Ø 22 cm.
 capacità 6000 cm³



ART. 29864
 † 25 Ø 20 cm.
 capacità 5500 cm³



ART. 29866
 † 24 Ø 24 cm.
 capacità 6500 cm³



ART. 29869
 † 26 Ø 20,5 cm.
 capacità 5000 cm³



ART. 29867
 † 24 Ø 24 cm.
 capacità 6500 cm³



ART. 29870
 † 26 Ø 20,5 cm.
 capacità 5000 cm³



ART. 29859
 ↓ 25 Ø 21 cm.
 capacità 6000 cm³



ART. 29862
 ↓ 25,5 Ø 22 cm.
 capacità 6000 cm³



ART. 29865
 ↓ 25 Ø 20 cm.
 capacità 5500 cm³



ART. 29872
 ↓ 25 Ø 21 cm.
 capacità 6000 cm³



ART. 29860 + lettera
 colorazione marmi scelta
 ↓ 25,5 Ø 22 cm.
 capacità 6000 cm³



ART. 29863 + lettera
 colorazione marmi scelta
 ↓ 25 Ø 20 cm.
 capacità 5500 cm³



ART. 29868
 ↓ 24 Ø 24 cm.
 capacità 6500 cm³



ART. 29871
 ↓ 26 Ø 20,5 cm.
 capacità 5000 cm³



ART. 29866 + lettera
 colorazione marmi scelta
 ↓ 24 Ø 24 cm.
 capacità 6500 cm³



ART. 29869 + lettera
 colorazione marmi scelta
 ↓ 26 Ø 20,5 cm.
 capacità 5000 cm³



ART. 29843
 ↓ 28 ↔ 19 cm.
 capacità cm³ 4100



ART. 29844
 ↓ 28 ↔ 19 cm.
 capacità cm³ 4100



ART. 29845
 ↓ 28 ↔ 19 cm.
 capacità cm³ 4100



ART. 29846
 ↓ 8 ↔ 7,5 cm.
 capacità cm³ 125



ART. 29847
 ↓ 8 ↔ 7,5 cm.
 capacità cm³ 125



ART. 29848
 ↓ 13 ↔ 9 cm.
 capacità cm³ 250



ART. 29849
 ↓ 13 ↔ 9 cm.
 capacità cm³ 250



ART. 29851 ↓ 14,5 ↔ 7 cm.
 capacità cm³ 90

ART. 29852 ↓ 18 ↔ 11,5 cm.
 capacità cm³ 550

ART. 29854 ↓ 14,5 ↔ 7,5 cm.
 capacità cm³ 225

ART. 29856 ↓ 7 ↔ 9 cm.
 capacità cm³ 90

ART. 29853 ↓ 14 ↔ 7 cm.
 capacità cm³ 140

ART. 29855 ↓ 14 ↔ 8 cm.
 capacità cm³ 250

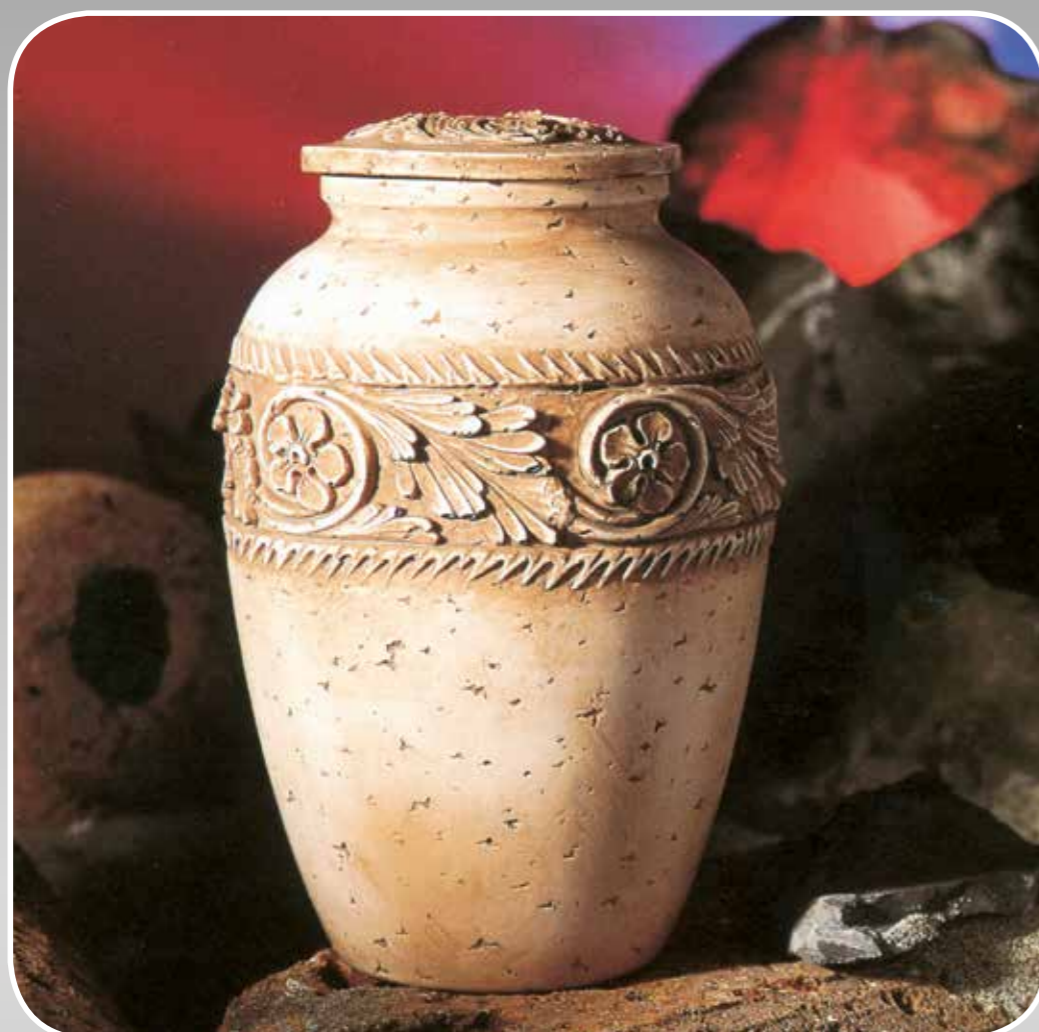

ART. 0600 ↓ 27 ↔ 18 cm.
capacità cm³ 3100



ART. 0601 ↓ 28 ↔ 24 cm.
capacità cm³ 2200



ART. 19900 ↓ 80 cm.

Si può richiedere anche di altezza diversa - Different heights can also be requested - Disponible dans différentes hauteurs
Sie ist auch in anderen Höhen erhältlich - También se puede pedir de altura diferente





cm. 11 x 6

ART. 39100
Targhetta liscia

ART. 39101
Targhetta incisa

ART. 39102
Targhetta liscia con incavo
miniatura

ART. 39103
Targhetta con incisione e
miniatura





1

Materiale necessario per il montaggio.
Material for assembly.
Matériel nécessaire pour le montage.
Benötigtes Material für die Montage.
Material necesario para el montaje.



2

Inserire l'anello di plastica nel lumino.
Insert the plastic ring into the lamp.
Introduire la bague en plastique dans la veilleuse.
Plastikring in das Gedächtnislämpchen stecken.
Insert el anillo de plastico en la lamparilla.



3

Portare l'anello fino all'estremità inferiore del lumino.
Position the ring at the lower end of the lamp.
Placer la bague à l'extrémité inférieure de la veilleuse.
Den Ring an das untere Lämpchenende schieben.
Desplazar el anillo hasta el extremo inferior de la lamparilla.



4

Inserire il lumino nel pezzo metallico.
Insert the lamp into the metal piece.
Introduire la veilleuse dans la pièce métallique.
Den Metallteil in das Lämpchen einführen.
Insertar la lamparilla en la pieza metálica.

5



ART. 90400 luce intermittente
↓ 5 Ø 3,5 cm.
alimentazione: 4 pile stilo o 1 pila 9V

ART. 90401 luce continua
↓ 5 Ø 3,5 cm.
alimentazione: 4 pile stilo o 1 pila 9V

A operazione ultimata, inserire la fiamma di vetro nel lumino.
Once these operations have been carried out, insert the glass flame into the lamp.
Dès que l'opération est terminée, placer le verre protecteur sur la veilleuse.
Nach Abschluß del montage Glas lämmchen in das Lämpchen einführen.
Una vez concluida la operación, colocar la camisa de vidrio en la lamparilla.

Luce intermittente= Flashing light - Lumière intermittente - Blinklicht - Luz intermitente
Luce continua= Continuous light - Lumière continue - Dauerlicht - Luz continua
Alimentazione= Power supply - Alimentation - Stormversorgung - Alimentación
Escluso pile - Batteries excluded - Pile non comprise - Ausschließlich Batterien - Exluidas pilas



Lumino votivo a pila per lampade Ø 5
● **ART. 90457**
↓ 10 ↔ 3 cm.
funziona con 2 stilo AA

ART. 90453 Luce intermittente

ART. 90445 Luce intermittente

ART. 90449 Luce intermittente



ART. 90474

Luce intermittente - Intermittent light
Lumière intermittente
Blinkende Leuchte - Luz intermitente

ART. 90475

Luce effetto candela - Candle effect light
Lumière effet bougie
Licht mit Kerzeneffekt - Luz efecto vela

durata: 90 giorni circa
duration 90 days approx
durée 90 jours environ
Brenndauer ca. 90 Tage
duración 90 días aprox.

h 10,5 cm Ø 6,3 cm



ART. 90476

Luce intermittente - Intermittent light
Lumière intermittente
Blinkende Leuchte - Luz intermitente

ART. 90477

Luce effetto candela - Candle effect light
Lumière effet bougie
Licht mit Kerzeneffekt - Luz efecto vela

Usa e getta Ø 5 cm - h. 12,3 cm

Votive lamp
Lumignon votif
Votivleuchte
Velas votivas

ART. 90485

LUCE ROSSA TREMOLANTE
Intermittent red light
Lumière intermittente rouge
Intermittiere rot Leuchte
Luz roja intermitente



(IT) Lumino votivo con reggifiamma inox. Durata della batteria oltre 30 gg. Fiamma in vetro non compresa.

(EN) Votive lamp complete of battery (AA) and stainless steel flame support. Instructions for the battery change directly on the lamp body. Battery life about 30 days. Glass flame not included.

(FR) Lumignon votif avec pile (AA) et support de flamme en inox. Les instructions de changement de la pile sont indiquées sur le corps du lumignon. Durée de la pile: 30 jours environ. Flamme en verre non comprise.

(DE) Votivleuchte mit Batterie (AA) und Flammenträger aus Edelstahl. Die Anleitung zum AUSTAUSCHEN der Batterie ist direkt am Gehäuse der Votivleuchte. Dauer der Batterie etwa 30 Tage. Flamme im Glas nicht inbegriffen.

(ES) Velas votivas con batería (AA) y soporte en inoxidable. Instrucciones para el cambio de la batería directamente sobre el cuerpo de la vela. Duración de la batería 30 días aproximadamente. Lumbre en vidrio no incluida.

Lumini luce intermittente - durata: 40 giorni circa

Disposable Votive Lights - Intermittent lights
duration 40 days approx.
Lumignons Votifs jetables - Lumignons
lumière intermittente
durée 40 jours environ
Einweggedächtnisleuchten - Blinkende
Leuchten
Brenndauer ca. 40 Tage
Lamparillas desechables - Lamparillas luz
intermitente
duración 40 días aproximadamente



ART. 90486 -

ART. 90464 -
Piccolo Gesù

ART. 90473 -
Santa Rita



ART. 90466 -
Maria Immacolata

ART. 90463 -
Madonna di Lourdes

ART. 90461 -
Cristo Risorto

ART. 90465 -
Cuore di Maria



ART. 90472 -
San Giuseppe

ART. 90462 -
Sacro Cuore

ART. 90468 -
Padre Pio

ART. 90470 -
Santa Teresa



ART. 90467 -
Madonna di Medjugorje

ART. 90469 -
Sacra Famiglia

ART. 90471 -
Sant'Antonio

ART. 90460 -
Angelo Custode



ART. 90600
contenuto 300 ml.

Multilind è il prodotto più indicato per la pulizia di accessori lapidei. Multilind agisce all'istante, pulendo e lucidando bronzi, marmi, graniti e porcellane mantenendo inalterate le caratteristiche del prodotto.

Multilind is the most advisable product for cleaning stony fittings.

Multilind acts instantly, cleaning and polishing bronzes, marbles, granites and porcelains, keeping the product unchanged.

Multilind est le produit le mieux indiqué pour nettoyer les accessoires des plaques. Multilind agit de manière immédiate: il peut nettoyer et polir les bronzes, les marbles, les granits et les porcelaines, sans modifier les caractéristiques du produit.

Multilind es el producto más adecuado para limpieza de accesorios lapídeos. Multilind funciona al instante, limpiando y lustrando bronzes, mármoles, granitos y porcelanas, manteniendo inalteradas las características del producto.

Scalpellini per martello pneumatico grande (attacco Ø 12,5)
ART. 95205 5 mm.
ART. 95206 6 mm.
ART. 95207 7 mm.
ART. 95208 8 mm.
ART. 95210 10 mm.
ART. 95212 12 mm.
ART. 95215 15 mm.
ART. 95218 18 mm.
ART. 95220 20 mm.
ART. 95222 22 mm.

Scalpellini per martello pneumatico piccolo (attacco Ø 7)
ART. 95304 4 mm.
ART. 95305 5 mm.
ART. 95306 6 mm.
ART. 95307 7 mm.
ART. 95308 8 mm.
ART. 95310 10 mm.
ART. 95312 12 mm.

Punte giranti
ART. 92025 Ø 2,5 mm.
ART. 92030 Ø 3 mm.
ART. 92035 Ø 3,5 mm.
ART. 92040 Ø 4 mm.
ART. 92050 Ø 5 mm.
ART. 92060 Ø 6 mm.
ART. 92070 Ø 7 mm.
ART. 92080 Ø 8 mm.
ART. 92090 Ø 9 mm.
ART. 92100 Ø 10 mm.
ART. 92111 Ø 11 mm.
ART. 92112 Ø 12 mm.
ART. 92115 Ø 15 mm.
ART. 92118 Ø 18 mm.
ART. 92120 Ø 20 mm.

Punte percussione
ART. 93030 Ø 3 mm.
ART. 93035 Ø 3,5 mm.
ART. 93040 Ø 4 mm.
ART. 93050 Ø 5 mm.
ART. 93060 Ø 6 mm.
ART. 93070 Ø 7 mm.
ART. 93080 Ø 8 mm.
ART. 93090 Ø 9 mm.
ART. 93100 Ø 10 mm.
ART. 93111 Ø 11 mm.
ART. 93112 Ø 12 mm.
ART. 93115 Ø 15 mm.
ART. 93118 Ø 18 mm.
ART. 93120 Ø 20 mm.

Bocciarde con attacco lungo e corto
ART. 95500 9 denti - Quadro 20 mm.
ART. 95501 16 denti - Quadro 20 mm.
ART. 95502 25 denti - Quadro 20 mm.
ART. 95503 9 denti - Quadro 25 mm.
ART. 95504 16 denti - Quadro 25 mm.
ART. 95505 25 denti - Quadro 25 mm.
ART. 95506 9 denti - Quadro 30 mm.
ART. 95507 16 denti - Quadro 30 mm.
ART. 95508 25 denti - Quadro 30 mm.
ART. 95509 9 denti - Quadro 35 mm.
ART. 95510 16 denti - Quadro 35 mm.
ART. 95511 25 denti - Quadro 35 mm.
ART. 95513 4 denti - Tondo Ø 22 mm.
ART. 95514 5 denti - Tondo Ø 22 mm.

Gradine a macchina a denti innestati
ART. 95400 2 denti - 12 mm.
ART. 95401 3 denti - 12 mm.
ART. 95402 2 denti - 15 mm.
ART. 95403 3 denti - 15 mm.
ART. 95404 4 denti - 15 mm.
ART. 95405 3 denti - 18 mm.
ART. 95406 4 denti - 18 mm.
ART. 95407 5 denti - 18 mm.
ART. 95408 3 denti - 20 mm.
ART. 95409 4 denti - 20 mm.
ART. 95410 5 denti - 20 mm.
ART. 95411 3 denti - 22 mm.
ART. 95412 4 denti - 22 mm.
ART. 95413 2 denti - 22 mm.

Scalpellini a mano
ART. 95030 3 mm.
ART. 95040 4 mm.
ART. 95050 5 mm.
ART. 95060 6 mm.
ART. 95070 7 mm.
ART. 95080 8 mm.
ART. 95100 10 mm.
ART. 95120 12 mm.
ART. 95150 15 mm.
ART. 95180 18 mm.
ART. 95200 20 mm.

Subbia
ART. 96040 Ø 4 mm.
ART. 96050 Ø 5 mm.
ART. 96060 Ø 6 mm.
ART. 96080 Ø 8 mm.
ART. 96100 Ø 10 mm.
ART. 96112 Ø 12 mm.

Punta
ART. 94000 Ø 5 - 19 cm.

CERMET
 Certificazione e ricerca per la qualità

CERMET Soc. Cons. a r.l.

 Headquarter Bologna : Via Cadriano, 23 - 40057 Cadriano - Granarolo Emilia (Bo)
 Tel. +39 051.764.811 - Fax +39 051.763.382 - info@cermet.it - www.cermet.it

P.I. 00627711203 - C.F. 03502820370 - Iscrizione Trib. BO n. 41500 del Registro Società - Capitale Sociale: € 421.245,00

RAPPORTO DI PROVA N. 2008-00234

TIPO DI PROVA:

1. PROVA DI CORROSIONE IN CAMERA A NEBBIA SALINA NEUTRA (NSS)
2. RESISTENZA AI RAGGI TIPO UV
3. CONDIZIONAMENTO IN CAMERA CLIMATICA

MATERIALE/CAMPIONE: N°9 MATTONELLE IN MATERIALE LAPIDEO

COMMESSA N° LBO08E00087

VS RICHIESTA DEL 2008-02-05

DATA RICEVIMENTO CAMPIONI 2008-02-05

COMMITTENTE **VEZZANI S.p.A.**
 Via Monte Tito, 3
 Montecavolo Quattro Castella - RE

DICHIARAZIONI

I dati contenuti nel presente rapporto di prova si riferiscono esclusivamente ai campioni consegnati dal Committente.

Il Committente si impegna a riprodurre integralmente il presente rapporto di prova; la riproduzione parziale deve essere autorizzata dal CERMET.

Cadriano di Granarolo, 2008-04-09

 Il Tecnico
 Sig. Emerike Nebedum

 Il Responsabile
 Dott. Enrico Costa

RAPPORTO DI PROVA N. 2008-00234
IDENTIFICAZIONE CAMPIONE E SCOPO ESAME

Il Committente ha consegnato n°9 campioni, identificati come segue:

Campione A: n°7 mattonelle in materiale lapideo con foto.

Campione B: n°2 mattonelle in materiale lapideo senza foto.

Nella Foto 1 sono rappresentati i campioni poi utilizzati per le prove allo stato di presentazione.



Foto 1 - N° 2 campioni A e n° 1 campione B allo stato di presentazione

Le prove sono state eseguite al fine di verificare il comportamento dei campioni in esame a condizioni ambientali estreme.

INIZIO ATTIVITA': 2008-02-18

FINE ATTIVITA': 2008-04-08

SINTESI ED INTERPRETAZIONE DEI RISULTATI DI PROVA

In base ai risultati delle prove si può esprimere la seguente considerazione:

- Al termine delle prove, su tutti i campioni esaminati, non si osservano variazioni di colore né fenomeni di sollevamento (bolle di rigonfiamento in superficie)

RAPPORTO DI PROVA N. 2008-00234
PROVA 1: PROVA DI CORROSIONE IN CAMERA A NEBBIA SALINA NEUTRA (NSS)
SPECIFICHE DI PROVA

Norme UNI EN ISO 9227-2006

APPARECCHIATURA DI PROVA

Camera a nebbia salina DCTC 1200P- ANGELANTONI CENTROSUD (Certificato di taratura Angelantoni N°03 del 2008-01-08).

CONDIZIONI DI PROVA

- soluzione salina:	50 ± 5 g/l di NaCl (5 %)
- pH :	6,5 + 7,2
- temperatura:	35 ± 2 °C
- K pluviometrica:	1 ± 2 cc/h
- controllo:	24, 48, 72, 96, 168, 192, 264, 336, 384, 432, 500 h
- fine prova:	500 h

La prova è stata eseguita su n°2 campioni del tipo A e su n°1 campione del tipo B.

In assenza di indicazioni specifiche, tutta la superficie esposta alla nebbia salina neutra è stata considerata significativa.
ESITO DI PROVA
t = tempo di esposizione = 24 h

Campioni A: nessuna variazione

Campione B: nessuna variazione

I controlli effettuati da t = 48 h fino a t = 432 h, non mostrano nessuna variazione nell'aspetto superficiale dei campioni in prova.

t = 500 h

Campioni A: come controllo precedente

Campione B: come controllo precedente

FINE PROVA

La Foto 2 documenta l'aspetto dei campioni al termine della prova.



RAPPORTO DI PROVA N. 2008-00234

Foto 2 - Campioni A e B a t = 500 h (NSS)

PROVA 2: RESISTENZA AI RAGGI TIPO UV
APPARECCHIATURA DI PROVA

Modello U.V. esposizione a lampade UV fluorescenti del tipo Ultra-Vitalux 300W/230V, senza condensa.

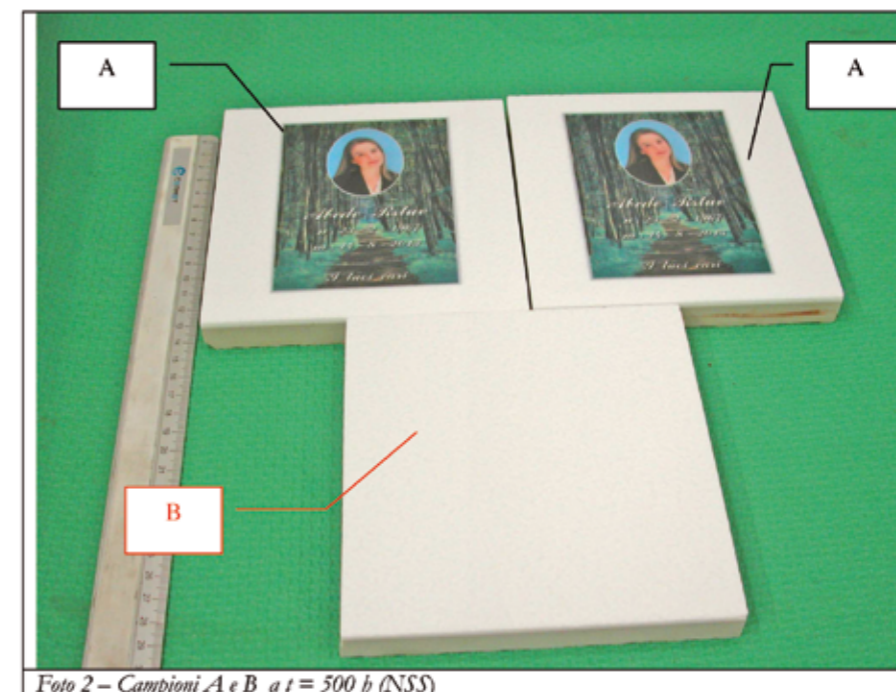
METODI DI PROVA E SPECIFICHE DI PROVA

Norme ASTM G 154-00 e UNI EN ISO 11507:2007.

CONDIZIONI DI PROVA

Cicli di prova: UV continua

Temperatura: UV 55°C

Controlli: 24, 48, 72, 96, 168, 192, 200, 250, 300, 350, 400, 450, 500 h

Fine prova: 500 h

La prova è stata eseguita su n°2 campioni del tipo A e su n°1 campione del tipo B.



RAPPORTO DI PROVA N. 2008-00234

ESITO DI PROVA

Nei controlli intermedi e a fine prova non si osservano particolari variazioni di colore né alterazioni superficiali.

La Foto 3 documenta l'aspetto dei campioni al termine della prova.



Foto 3 - Campioni A e B a $t = 500$ h (UV)



RAPPORTO DI PROVA N. 2008-00234

PROVA 3: CONDIZIONAMENTO IN CAMERA CLIMATICA

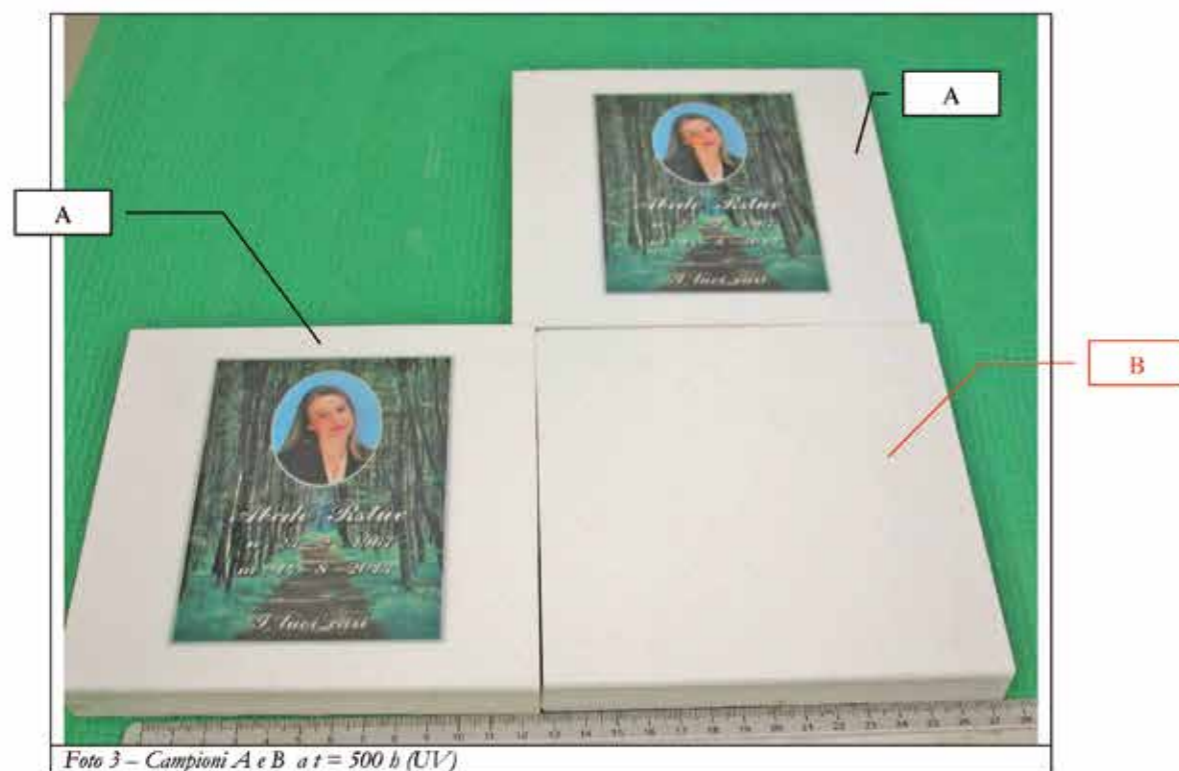
APPARECCHIATURA

Camera climatica ANGELANTONI CH1200 (certificato Angelantoni n°01/08 del 2008-01-08)
DATA LOGGER AGILENT 34970A, equipaggiato di sonde di temperature di tipo K RS components Cod. RS: 219-4315 (certificato n°070962 2TRI del 2007-10-22)

METODI DI PROVA E SPECIFICHE DI RIFERIMENTO

Norma EN 14678-1:2006, paragrafo 5.3.

CONDIZIONI DI PROVA

Temperatura max: +40°C
Temperatura min: -30°C
U.R: 98 %
Ciclo di prova: vedi Grafico 1
N° cicli: 21

La prova è stata eseguita su n°3 campioni del tipo A.

Per monitorare la temperatura delle mattonelle sono state applicate 3 sonde di tipo K. L'allestimento dell'attrezzatura di prova è mostrato in Foto 4.



Foto 4 - Campioni A a $t = 168$ h



RAPPORTO DI PROVA N. 2008-00234

Il grafico seguente illustra il ciclo di prova realizzato; durante ciascun ciclo, di durata pari a 8 ore, la temperatura di prova viene fatta variare tra +40°C e -30°C.



Grafico 1: ciclo di prova

RISULTATI DI PROVA



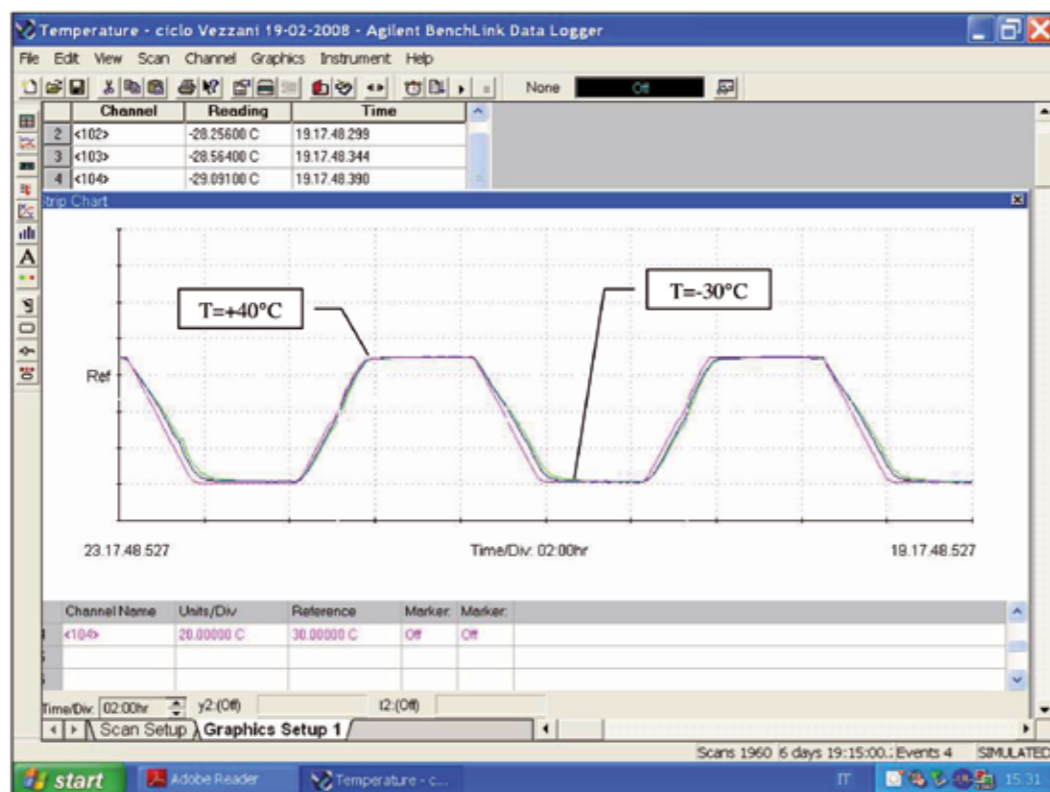

Al termine della prova (n°21 cicli corrispondenti a d un tempo pari a 168 h di prova), non è stata riscontrata nessuna variazione nell'aspetto superficiale dei campioni in prova.

AVVERTENZE







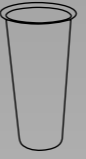

I campioni di prova vengono conservati per 6 mesi dopo la consegna dei documenti di prova. Le eccedenze dei campioni di prova vengono stoccate in atmosfera industriale; ciò potrebbe comportare un deterioramento che ne compromette l'utilizzo o la ripetizione delle prove. CERMET non garantisce che trascorso questo intervallo di tempo, i campioni siano ancora rintracciabili.

INTERNI Rame

	DESCRIZIONE	PREZZO		DESCRIZIONE	PREZZO
	art. 73953 ↓ 10 Ø 14,6 cm			art. 73959 ↓ 15,5 Ø 22,2 cm	
	art. 73956 ↓ 14,5 Ø 18,8 cm			art. 73955 ↓ 12 Ø 20,08 cm	
	art. 73952 ↓ 14,5 Ø 29,1 cm			art. 73833 ↓ 14,5 ↗ 6 ↔ 11,3 cm	
	art. 73011 ↓ 19,5 Ø 20,2 cm			art. 73958 ↓ 15 Ø 13,2 cm	
	art. 73811 ↓ 14,5 ↗ 6,1 ↔ 12 cm			art. 73507 ↓ 8,5 Ø 7,5 cm	
	art. 73508 ↓ 11 Ø 10 cm			art. 73014 ↓ 26 Ø 17,2 cm	
	art. 73012 ↓ 26 Ø 18,6 cm			art. 73802 ↓ 18,8 Ø 11,1 cm	
	art. 73803 ↓ 22,5 Ø 12,9 cm			art. 73961 ↓ 21 Ø 8,9 cm	
	art. 73981 ↓ 25,5 Ø 12,1 cm			art. 73962 ↓ 25 Ø 9,8 cm	

	art. 73980 ↓ 16,5 Ø 8,2 cm		art. 73804 ↓ 16 Ø 7,5 cm
	art. 73978 ↓ 13,5 Ø 6,2 cm		art. 73867 ↓ 18 Ø 7,1 cm
	art. 73868 ↓ 17 Ø 6,9 cm		art. 73505 ↓ 17,5 Ø 7,1 cm
	art. 73827 ↓ 18 Ø 7,5 cm		art. 73967 ↓ 17,5 Ø 8 cm
	art. 73013 ↓ 11,5 Ø 18,5 cm		art. 73968 ↓ 15 Ø 5,7 cm
	art. 73969 ↓ 12 Ø 5,1 cm		art. 73515 ↓ 9 Ø 4,6 cm
	art. 73856 ↓ 12,7 Ø 1,8 cm		art. 73989 ↓ 11,7 Ø 5,7 cm
	art. 73902 ↓ 33,5 Ø 13,3 cm		art. 73826 ↓ 26,5 Ø 13,9 cm
	art. 73821 ↓ 18,5 Ø 9,9 cm		art. 73903 ↓ 16,8 Ø 6,1 cm
	art. 73960 ↓ 18,5 Ø 7 cm		art. 73905 ↓ 14,5 Ø 6,1 cm

Tutte le misure sono da intendersi sottobordo.

	art. 73983 ↓ 24 Ø 10,6 cm		art. 73904 ↓ 10,4 Ø 4,5 cm
	art. 73986 ↓ 14,5 Ø 6,5 cm		art. 73982 ↓ 17 Ø 8,2 cm
	art. 73702 ↓ 19,7 Ø 9,1 cm		art. 73984 ↓ 11,7 Ø 5,3 cm
	art. 73800 ↓ 11,5 Ø 6,9 cm		art. 73801 ↓ 16 Ø 9,2 cm

Tutte le misure sono da intendersi sottobordo.











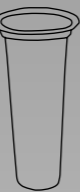

INTERNI **Plastica**

DESCRIZIONE		PREZZO	DESCRIZIONE		PREZZO
	art. 70399 ↓ 27 ↗ 7,8 ↔ 17,1 cm nero			art. 70395 ↓ 19 ↗ 5,4 ↔ 11,1 cm nero	
	art. 70390 ↓ 16 ↗ 5,3 ↔ 11,1 cm nero			art. 70380 ↓ 10 ↗ 3,2 ↔ 6,6 cm nero	
	art. 70375 ↓ 28 ↗ 9,9 ↔ 16,9 cm nero			art. 70621 ↓ 16,5 ↗ 7,4 ↔ 18,1 cm nero	
	art. 70367 ↓ 17,5 ↗ 5,9 ↔ 10,3 cm nero			art. 73602 ↓ 25 Ø 9,5 cm nero	
	art. 73603 ↓ 23,5 Ø 8,5 cm nero			art. 70211 ↓ 17,5 Ø 7,8 cm marrone	
	art. 70210 ↓ 14 Ø 6,2 cm marrone			art. 70209 ↓ 10 Ø 5 cm marrone	
	art. 70215 ↓ 14,5 Ø 5,6 cm bianco			art. 73661 ↓ 15,5 Ø 7,3 cm marrone	
	art. 70218 ↓ 11,5 Ø 4,8 cm marrone			art. 70217 ↓ 16 Ø 9 cm marrone	
	art. 70216 ↓ 18,5 Ø 9,9 cm marrone			art. 73671 ↓ 11,5 Ø 5,8 cm marrone	

Tutte le misure sono da intendersi sottobordo.

	art. 70232 ↓ 14,5 Ø 6,2 cm marrone			art. 70230 ↓ 14,6 Ø 6,3 cm bianco	
	art. 73670 ↓ 10,5 Ø 4,5 cm marrone			art. 70212 ↓ 18,5 Ø 7,5 cm marrone	
	art. 73601 ↓ 19 Ø 7,4 cm marrone			art. 73600 ↓ 18,6 Ø 7,4 cm marrone	
	art. 70221 ↓ 18,5 Ø 7,3 cm bianco			art. 73660 ↓ 18,5 Ø 7,3 cm marrone	
	art. 73673 ↓ 17,5 Ø 7 cm bianco			art. 73672 ↓ 17,5 Ø 7 cm nero	
	art. 70235 ↓ 26 Ø 10,3 cm bianco			art. 73613 ↓ 25,5 Ø 10 cm marrone	
	art. 70292 ↓ 21 Ø 7,9 cm bianco			art. 70265 ↓ 19 Ø 6,1 cm bianco	
	art. 70264 ↓ 17 Ø 5,8 cm bianco			art. 70263 ↓ 15 Ø 4,4 cm bianco	
	art. 70273 ↓ 17 Ø 6,1 cm bianco			art. 70289 ↓ 17 Ø 5,3 cm bianco	
	art. 70272 ↓ 15,5 Ø 5,3 cm bianco			art. 70271 ↓ 12,6 Ø 4 cm bianco	

Tutte le misure sono da intendersi sottobordo.

	art. 70270 ↓ 9,2 Ø 3,2 cm bianco		art. 70281 ↓ 32 Ø 10,8 cm bianco
	art. 70280 ↓ 24,5 Ø 9,1 cm bianco		art. 70290 ↓ 17,5 Ø 6,3 cm bianco
	art. 70291 ↓ 17,5 Ø 6,4 cm nero		art. 70220 ↓ 14,5 Ø 4,9 cm bianco
	art. 70262 ↓ 11,7 Ø 3,4 cm bianco		art. 70261 ↓ 9,5 Ø 2,8 cm bianco
	art. 70261M ↓ 9,5 Ø 2,8 cm marrone		art. 73621 ↓ 21 Ø 10,3 cm bianco
	art. 70231 ↓ 17,4 Ø 6,2 cm bianco		art. 70233 ↓ 12,2 Ø 6,2 cm bianco
	art. 73653 ↓ 16,6 ↗ 6,2 ↔ 12 cm marrone		art. 73650 ↓ 17 ↗ 6,2 ↔ 12 cm marrone
	art. 73651 ↓ 14 ↗ 6,2 ↔ 12,2 cm marrone		art. 73656 ↓ 17,5 ↗ 6,2 ↔ 14,1 cm bianco
	art. 73655 ↓ 17,5 ↗ 6,2 ↔ 14,1 cm marrone		art. 73658 ↓ 14,5 ↗ 5,8 ↔ 11,3 cm bianco
	art. 70266 ↓ 17,5 ↗ 6 ↔ 8,8 cm marrone		art. 70400 ↓ 15,2 ↗ 7,4 ↔ 11 cm marrone



Tutte le misure sono da intendersi sottobordo.

	art. 70402 ↓ 10,5 ↗ 6,8 ↔ 34,5 cm marrone		art. 70403 ↓ 14,5 ↗ 7,4 ↔ 23,7 cm bianco
	art. 70401 ↓ 14,5 ↗ 7,4 ↔ 23,7 cm marrone		

INTERNI Alluminio

DESCRIZIONE		PREZZO	DESCRIZIONE		PREZZO
	art. 73990 ↓ 18,2 Ø 9,3 cm nero			art. 73976L ↓ 18 Ø 8,7 cm nero	
	art. 73976 ↓ 17,5 Ø 8,7 cm nero			art. 73975 ↓ 10 Ø 8,7 cm nero	
	art. 73703 ↓ 17,5 Ø 8,7 cm nero				

INTERNI Inox

DESCRIZIONE		PREZZO	DESCRIZIONE		PREZZO
	art. 70902 ↓ 23,5 Ø 10 cm			art. 70900 ↓ 17,5 Ø 7,5 cm	
	art. 70910 ↓ 17,5 Ø 7,5 cm				

Tutte le misure sono da intendersi sottobordo.

Ghiere Bronzo

DESCRIZIONE		PREZZO	DESCRIZIONE		PREZZO
	art. 77821			art. 77826	
	art. 77602			art. 77603	
	art. 77613			art. 77660	
	art. 77650				

Ghiere Plastica

DESCRIZIONE		PREZZO
	art. 77622 bianco	
	art. 77623 marrone	

Tutte le misure sono da intendersi sottobordo.



VEZZANI